



CAMPUS WAYFINDING SIGNAGE GUIDELINES

Louisiana State University
BATON ROUGE, LOUISIANA

Approved by Chancellor Michael Martin on 03/18/2010

LSU OFFICE OF
FACILITY DEVELOPMENT
& CAMPUS PLANNING



March 1, 2010

Memo

To: Michael Martin, Chancellor

Through: Eric Monday, Interim Vice Chancellor
Finance & Administrative Services

Through: Tony Lombardo, Interim Assistant Vice Chancellor
Facility Services

Through: Emmett David, Director
Office of Facility Development

From: Jason P. Soileau, Assistant Director
Office of Facility Development

Re: **LSU Campus Wayfinding Signage Guidelines – Recommendation for Approval**

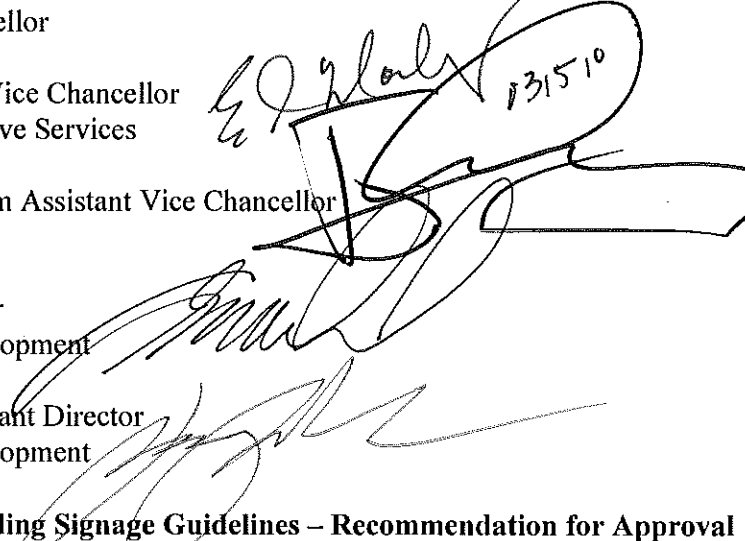

Sasaki and Associates in cooperation with the LSU Wayfinding Management Team recently completed the Louisiana State University Campus Wayfinding Signage Guidelines. The LSU Wayfinding Management Team, providing fair representation of the overall campus community, met on a regular basis from March 2008 through December 2009 in the development of the final document by Sasaki and Associates. This process included multiple presentations to a larger working group, including breakout meetings with campus auxiliary units and Facility Services – Resources representatives and included active participation from Student Government as well as the University Facility Development and Design Committee.

A mock up study and campus survey was performed in August 2009, which resulted in the following results:

- 76% “Strongly Agree” or “Agree” that the signs are appropriate for the campus
- 72% “Strongly Agree” or “Agree” that the signs showcase the LSU spirit
- 84% “Strongly Agree” or “Agree” that the signs clearly inform the user

It is the recommendation by the LSU Wayfinding Management Team that the attached Campus Wayfinding Management Signage Guidelines be adopted by the University; thereby, requiring all future signs to conform to the process and design standard established within the referenced document.

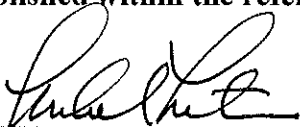

3/18/10

Approved – Michael Martin, Chancellor

cc: file

TABLE OF CONTENTS

- The role of campus wayfinding 5
- Introduction 6
- 1. DESIGN PRINCIPLES 13**
 - Themes and design inspiration
 - Wayfinding strategy
 - Wayfinding plan
 - Destination hierarchy
 - Sign location plans
 - Campus map strategy
- 2. SIGN DESIGNS 27**
 - Campus identity
 - Vehicular wayfinding and parking
 - Facility identification
 - Pedestrian wayfinding
 - Alternative transportation
 - Event signs
- 3. DETAILS AND SPECIFICATIONS 101**
 - University identity
 - Typography
 - Sign colors and materials
 - Symbols and arrows
 - Standard details
 - Individual sign details
- 4. APPENDIX 157**
 - Performance specifications
 - Retail guidelines
 - LSU campus map - affiliates



THE ROLE OF CAMPUS WAYFINDING FOR LSU

Wayfinding is an experience: that of an individual attempting to make their way through an unfamiliar environment. When the information needed to access that environment is provided in a thoughtful, structured fashion, the unfamiliar quickly becomes comfortable, friendly, welcoming. A successful wayfinding system manages this experience, using signage as a communication tool to not only facilitate access, but also to reflect the institutional culture and complement the architecture and environment of its setting.

WAYFINDING SYSTEM OBJECTIVES

Honor the LSU tradition

Capture the cultural character of Baton Rouge

Evoke the spirited attitude of both students and fans

Reinforce the LSU brand

Clearly inform, direct, and orient

Create a safer, more user-friendly environment

INTRODUCTION

LSU has acknowledged the substantial impact signs have on the campus landscape as well as on the ability of visitors to successfully navigate the university environment.

Disorganized and inconsistent signs can actually detract from a campus environment, leading to the complaint of “sign clutter” on campus while risking confusion of campus visitors. In the absence of a formally documented sign program, inconsistency of execution over time can cause campus signs to evolve to this state despite the best efforts of those who maintain them.

The program summarized in this document formalizes a family of signs that will enhance the campus environment and improve wayfinding. The manual also serves as a definitive sign policy for Louisiana State University. The sign designs are a response to the character of the main campus, providing an effective, yet “low-key” presence in the landscape while reinforcing LSU’s graphic and color identity. The designs also provide a means to consistently apply this identity to satellite campus locations. Components of the program are designed to enable flexible application to a variety of installation conditions, and are responsive to the capabilities of the LSU sign shop for maintenance and updating over time.



The guidelines are intended to comply with applicable MUTCD, ADA, and LADOT codes

WAYFINDING DESIGN PROCESS

The Guidelines were developed in collaborative fashion, with input from the Office of Facility Development and Campus Planning, a wide spectrum of campus stakeholders and the campus community along with the consultant.

WAYFINDING MANAGEMENT TEAM

The primary University decision-making authority for development of the signage guidelines was the Wayfinding Management Team, whose responsibilities were direction-giving and providing reports and recommendations to the Chancellors.

The Wayfinding Management Team consisted of the following departments and representatives:

- Facility Development and Campus Planning - *Jason Soileau*
- Finance and Administrative Services - *Eric Monday*
- Facility Development and Campus Planning - *Emmett David*
- Academic Affairs - *Chuck Wilson*
- Office of Communications and University Relations- *Holly Cullen, Jewel Hampton*
- Facility Development and Design Committee - *Van Cox*
- Student Government - *Corey Weber '08, Jordan Milazzo '09*

STAKEHOLDERS

The Wayfinding Management Team sought early input and regular feedback from a larger Working Group. The Working Group provided a broad representation of the campus community, and by being involved early and frequently in the design process, helped gain support for adoption of the sign guidelines. The Working Group consisted of representatives from the following campus stakeholders: *Parking, Athletics, UREC, Residential Life, Student Union, Dining, Bookstore, Law School, Ag Center, Student Health and University Auxiliary Services, as well as student participation through Student Government.*

PROGRAM ADMINISTRATION

The Louisiana State University Campus Wayfinding Signage Guidelines establishes standards for design, programming, implementation and upkeep of all permanent exterior signs on the LSU main campus, as well as guidelines for appropriate use of temporary, event-based exterior signs. These standards must be adhered to in order to promote a consistent and easily navigable environment for members of the campus community and guests alike. Non-conforming or non-approved signs will be subject to immediate removal.

AUTHORITY

Implementation and maintenance of the sign system is the responsibility of the Office of Facility Services. All proposals or requests for installation of exterior signs on campus, including regulatory and safety related signs, should be addressed to the Office of Facility Development and Campus Planning, and are subject to its approval.

IMPLEMENTATION

Updates, replacement, or new sign orders on a small scale will be coordinated by the Office of Facility Development or implemented by the sign shop from stock-on-hand. Requests which qualify will be released by the Office of Facility Development directly to the sign shop for implementation. Larger sign orders may be issued as contract documents for bidding by commercial sign fabricators. This process requires collaboration with the Office of Facility Development and Campus Planning to prepare a full bid package, which will reference the Louisiana State University Campus Wayfinding Signage Guidelines and set explicit requirements for shop drawings, sample submittal, and performance specifications.

MANUAL USE

The Louisiana State University Campus Wayfinding Signage Guidelines manual is available for all to review from the Office of Facility Development and Campus Planning website. It is intended for use by administrators, consultants, planners and the University facilities and planning staff. *When special conditions arise which are not addressed in this manual, consult with the Office of Facility Development and Campus Planning.*

MANUAL COMPONENTS

The *Sign Designs* section of the manual explains the design of each sign in the program, along with guidelines for its application and implementation. As such it should be consulted for information regarding the appropriate use for a given sign, standards for sign messages, and location and orientation in the campus environment. Consistent application of these guidelines over time will ensure a coherent, uncluttered and easily navigable sign system. The *Details and Specifications* section provides dimensions and details for each sign type, and can form the foundation for project bid documents.

REVISIONS AND UPDATES

As phased implementation of signs occur, facility planners should request construction of prototypes in order to confirm design details and standardize fabrication methods. Design refinements as a result of prototype review should be incorporated into future revisions of this document.

Wayfinding Feedback Report

September 17, 2009

Project Background:

Sasaki Associates has been working with the University to produce a systematic campus wayfinding master plan to guide the location of new directional and informational signs at LSU as well as to provide aesthetic guidance for production of such signage. Jason Soileau, Assistant Director Facility Development, will serve as primary spokesperson.

An executive management team and working group have been collaborating with Sasaki Associates consultants since the inception of this project. It has been an open, participative process with student, staff and faculty representation.

Temporary signs were installed using temporary materials for the purpose of evaluating design, color choice, scale, font, and overall style. These temporary mock-ups were installed to determine appropriateness of appearance, clarity and overall context, and therefore had not been edited for content accuracy. Additional corrugated yard signs were placed next to the temporary signs indicating that the signs were not intended for navigation but for concept testing.

A total of thirteen signs were placed throughout campus for a period of one month at the start of the Fall 2009 academic semester. These signs were categorized by the development team in one of three areas: large-scale vehicular, small-scale vehicular, and pedestrian.

Feedback Goals:

To enable LSU audience groups and stakeholders to provide feedback about the new wayfinding signs and kiosks with regard to the following:

- **Appearance:** Does the overall appearance (form and shape) of the sign mock-up feel appropriate for the campus and immediate surroundings? Do the colors feel appropriate for the campus and immediate surroundings? Does the typography?
- **Clarity:** Is the text legible? Is the information clearly organized? Does the location seem appropriate?
- **Context:** Is the sign mock-up the right size for the selected location? Does the location seem appropriate?

Methodology:

In order to receive input related to the temporary signage in place August 10 – September 11, 2009, the LSU Office of Communications and University Relations instituted a 10-question feedback poll through Broadcast email targeting current LSU students, faculty, and staff.

One email blast was sent to a population of approximately 28,000 students, 1,300 faculty, and 3,800 staff.

Feedback Project Stakeholders:

Jason Soileau, Assistant Director, Office of Facility Development – Campus Planning
 Holly Houk Cullen, Assistant Vice Chancellor, University Relations

Report Prepared by: Tricia Milford-Hoyt, Marketing Director, University Relations

Section B, Question 3: NO – Pedestrian



Please review the above photo(s) and state your agreement or disagreement with the statements below to the best of your ability.

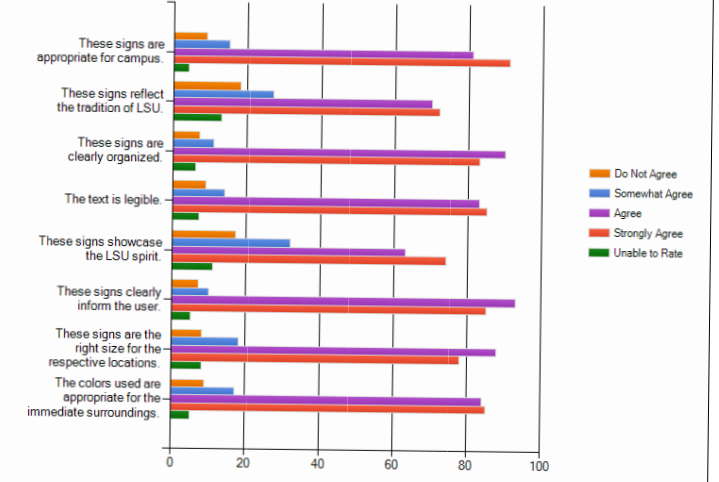

Sample of Wayfinding Feedback Report



1 DESIGN PRINCIPLES

The physical context of LSU's campus is a direct expression of the University's history, living traditions, and spirit. The campus is welcoming, authentic, unique, and above all, valued by all; any addition to this environment must be carefully considered. Before any designs were produced, several key attributes were examined to create a foundation of authenticity:

THEMES AND DESIGN INSPIRATION

WAYFINDING STRATEGY

WAYFINDING PLAN

DESTINATION HIERARCHY

SIGN LOCATION PLANS

CAMPUS MAP STRATEGY

THEMES AND DESIGN INSPIRATION

TRADITION, ENTHUSIASM, COLOR, VITALITY



LSU SPIRIT AND THE LSU CAMPUS

Concurrent with the design of the functional wayfinding program, the wayfinding team immersed themselves in the LSU physical and cultural context with the goal of distilling themes, ideals and design inspiration that should inform the design approach to the wayfinding system. In many cases, this was a process of clarifying the emotional effect of the campus and giving it form. Some of the broad themes that were embraced and incorporated into the signage include:

- Unusually heartfelt sense of pride, tradition and enthusiasm
- Academics and athletics are connected and their qualities contribute to the LSU experience
- LSU purple and gold is omnipresent
- Historic quad is welcoming and intimate
- Soft tones of stucco, bronze and tile roofs
- The historic buildings feel classic and clean, eternal
- Rich and simple details; not overly ornamental
- Strong lines, pure geometry, blend of modern and classic
- A blend of styles that seem to all work together



LSU CAMPUS



BATON ROUGE

WAYFINDING STRATEGY

ORGANIZING PRINCIPLES

Numerous organizational ideas were explored, based on creation of campus districts, or schemes based on landmark destinations, historic areas, secure and non-secure areas.

In the final analysis, the preferred scheme reflects a true “mental map” of the way the campus is experienced: via driving the three north-south corridors (Nicholson, Highland, and Lakeshore) and negotiating the pedestrian campus core and its gated access.

The wayfinding scheme is organized around the following:

- Three main corridors
- Central campus and visitor center
- Major destinations, serving as “anchors”

The majority of campus destinations reachable by car are accessed off these corridors. The corridors are also a natural and logical basis for direction-giving. This scheme features longevity and flexibility as the campus evolves and expands around this basic framework.

One campus, three different flavors

People experience the campus along three major arteries

Destinations are accessed from the arteries



Athletic (Nicholson Boulevard)

Academic (Highland Avenue)

Natural (Lakeshore Drive)

CAMPUS FLAVORS

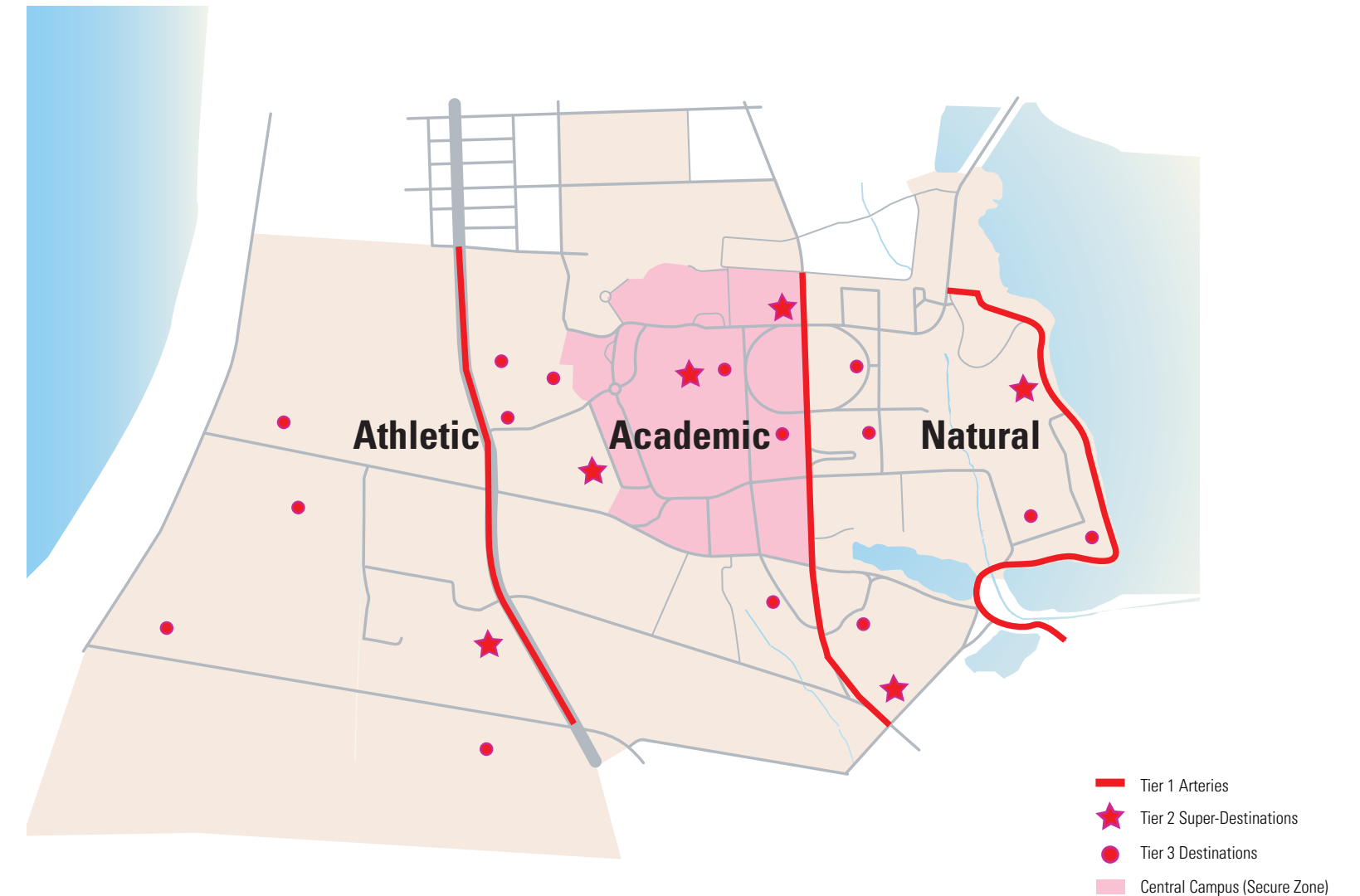

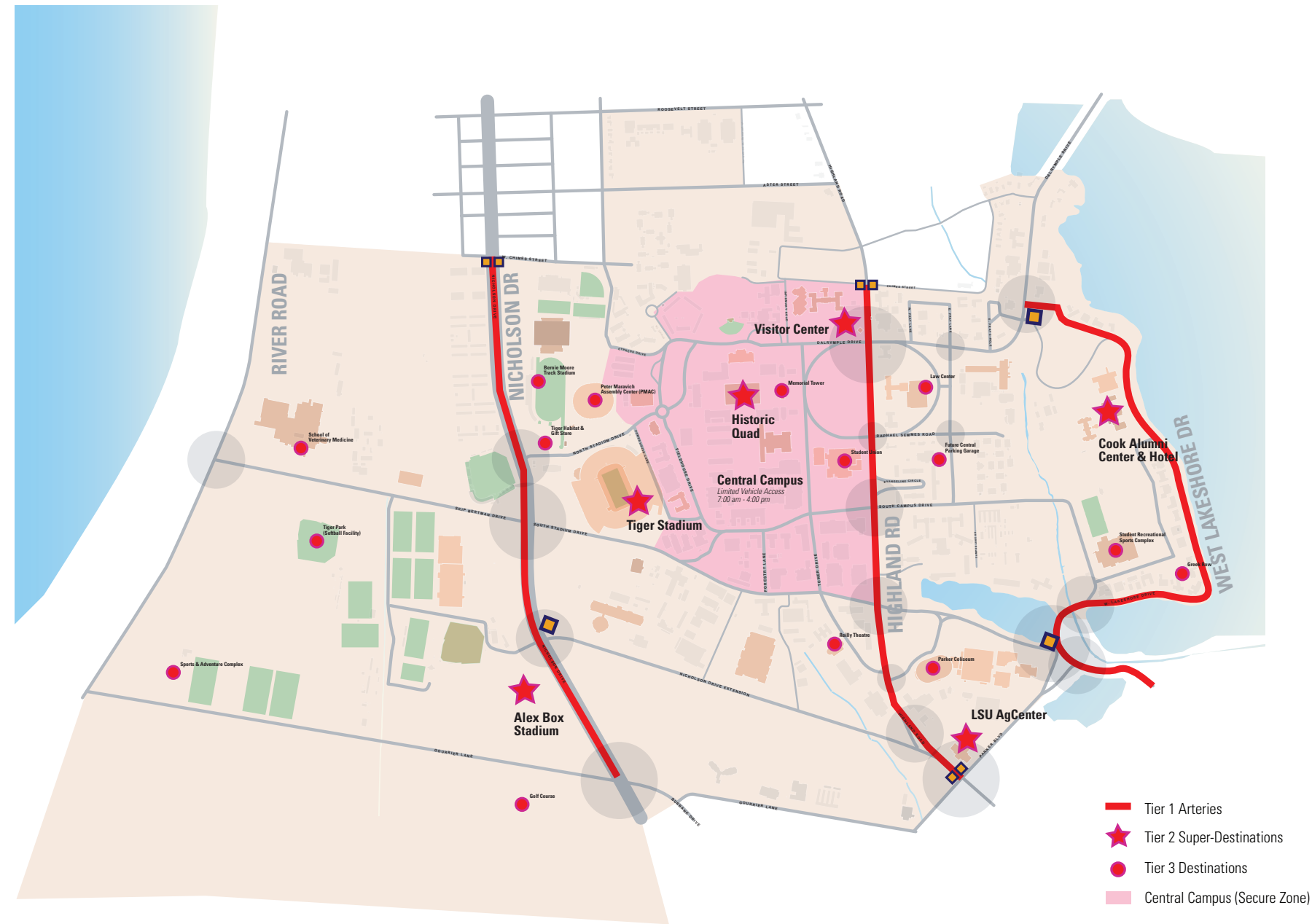

DESTINATIONS STRATEGY

The following hierarchy lists the approved ranking and official nomenclature of sign messages. The Tiers are based on a sorting by frequency of visitation and first time visitor needs.

This enables a break down of the campus into logical segments and manageable experience. Additional destinations will appear on new campus maps.

Sample Vehicular Directional
Showing Tier 1 & Tier 2 destinations

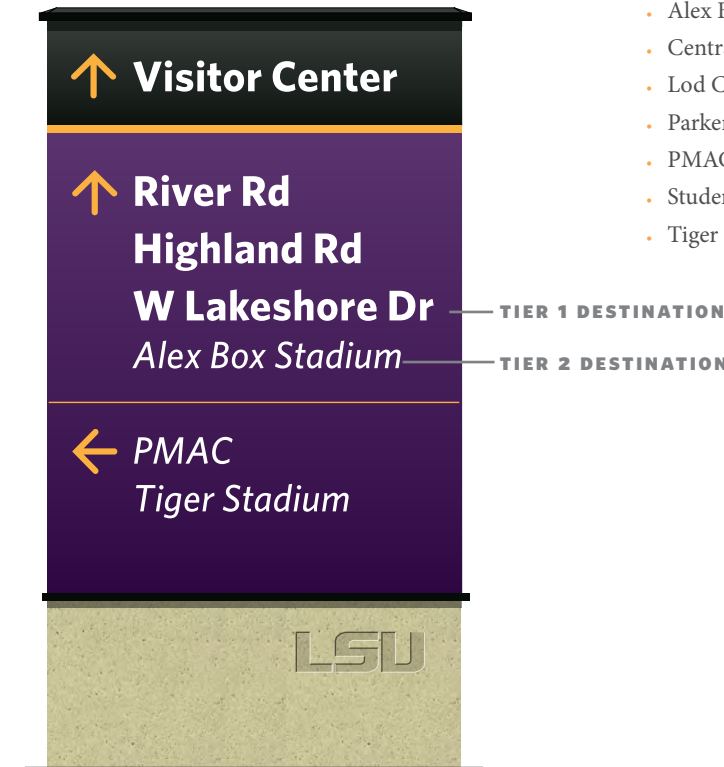

DESTINATION HIERARCHY

TIER 1

VISITOR CENTER AND VEHICULAR ARTERIES ONLY

Appearing on vehicular directional signs:

- Highland Road
- Nicholson Drive
- Visitor Center
- West Lakeshore Drive
- Rive Road

TIER 2

LANDMARKS ONLY

Appearing on vehicular directional signs:

- Alex Box Stadium
- Central Campus
- Lod Cook Alumni Center & Hotel
- Parker Coliseum
- PMAC
- Student Union
- Tiger Stadium

TIER 3

MAJOR DESTINATIONS

Appearing on pedestrian directionals, prominent facility identification, and maps—but not on vehicular directional signs:

- Andonie Museum
- Central Parking Garage (Future)
- Golf Course
- Greek Row
- Historic Quadrangle
- Lab School
- Paul M. Hebert Law Center
- LA House
- LSU System Building
- Memorial Tower
- Public Safety/Police
- Reilly Theatre
- School of Veterinary Medicine
- Sports & Adventure Complex (SAC)
- University Recreational Complex (UREC)
- Student Union
- Tiger Habitat / LSU Sports Store
- Tiger Park

TIER 4

SECONDARY DESTINATIONS

Appearing on pedestrian directionals and prominent facility identification and maps—but not on vehicular directional signs:

- Child Care Center
- Dining Halls
- Residence Halls
- Student Health Center

SIGN LOCATION PLAN

GATEWAYS AND DIRECTIONALS

The following plans illustrate diagrammatic locations for signs on the Main Campus. These diagrams are intended for planning and budgeting purposes only. Specific, phased installation projects will require field verification of precise locations and finalized messaging.

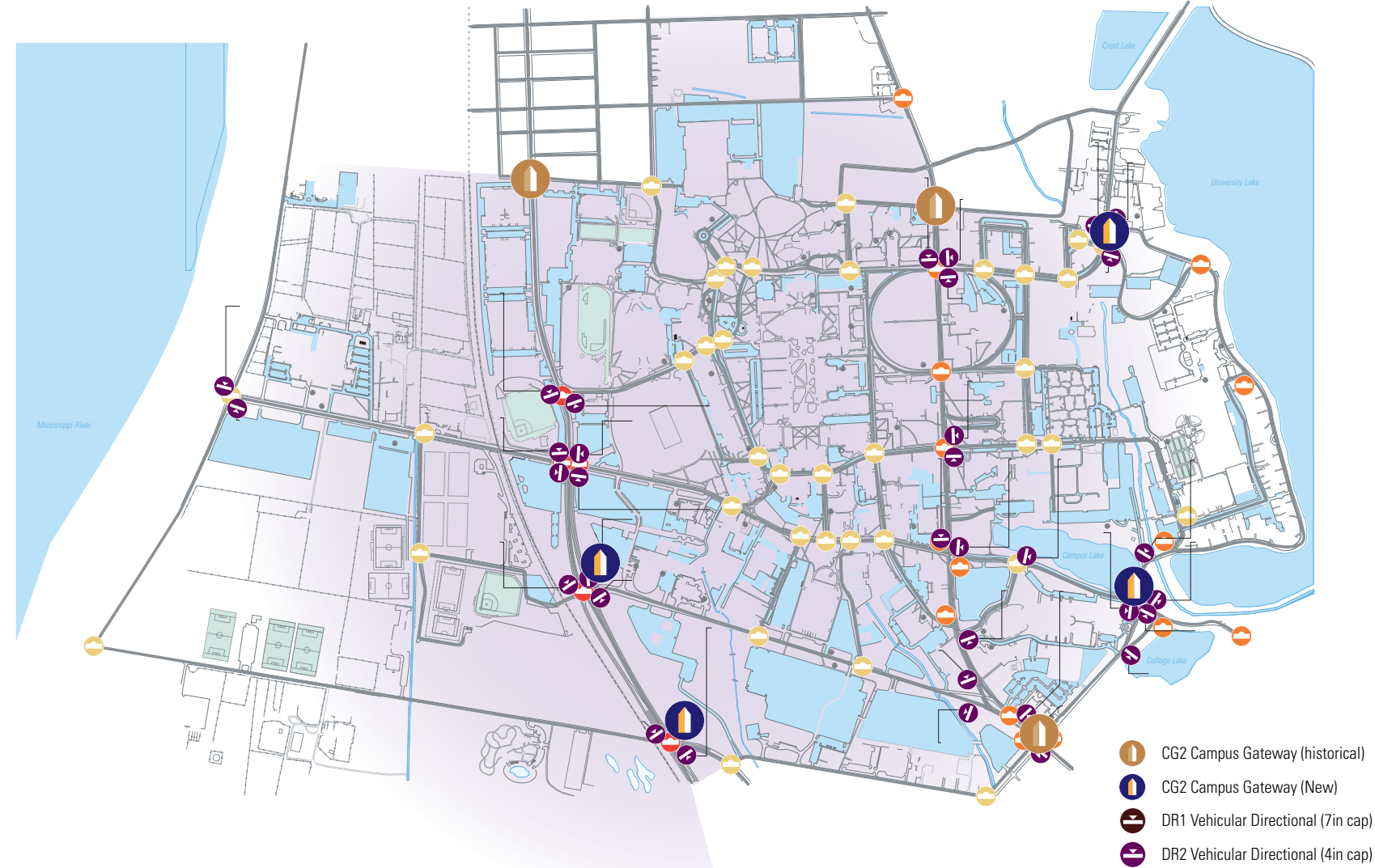

SIGN LOCATION PLAN

PARKING AND KIOSKS

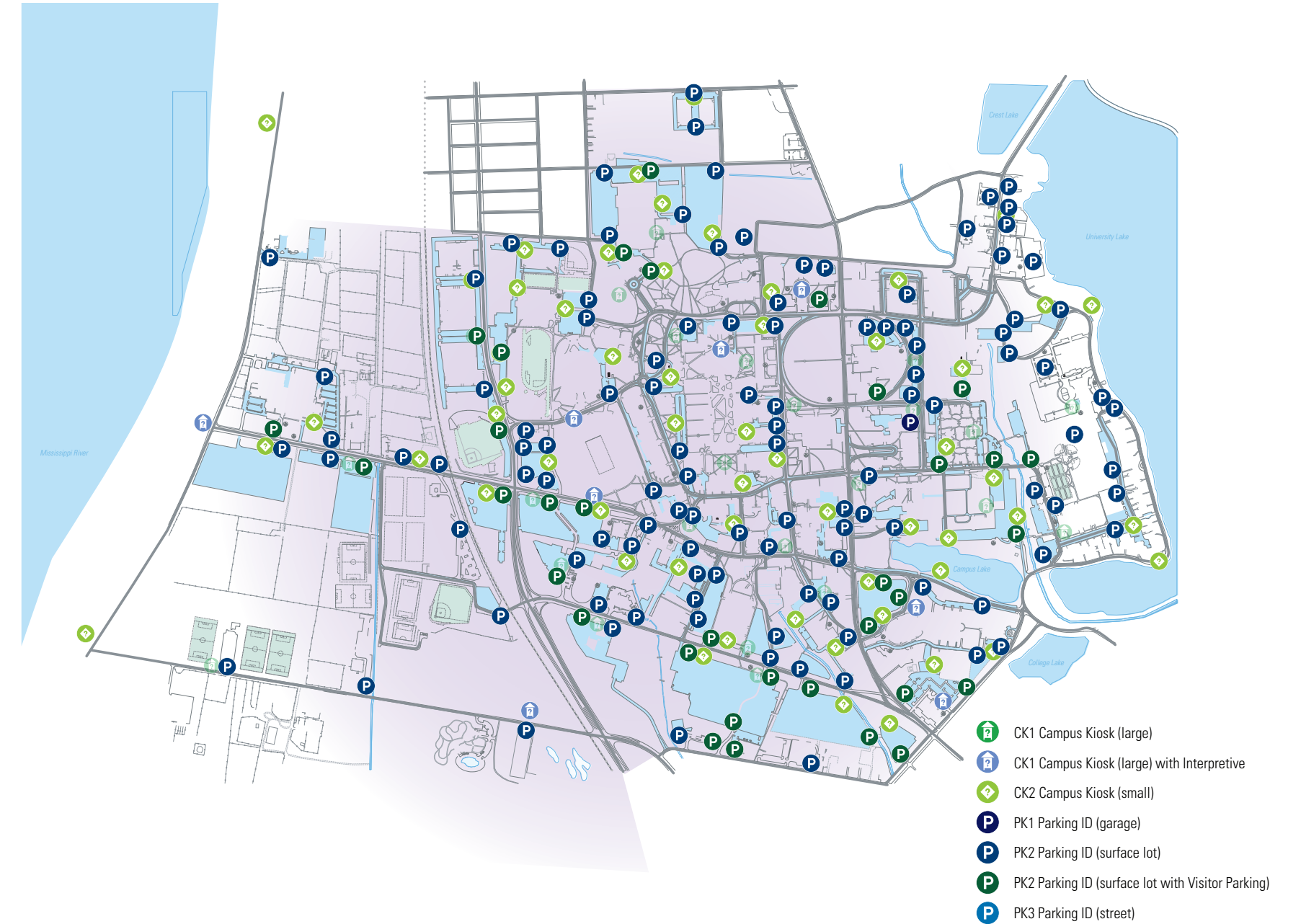

SIGN LOCATION PLAN

IDENTITY BANNERS

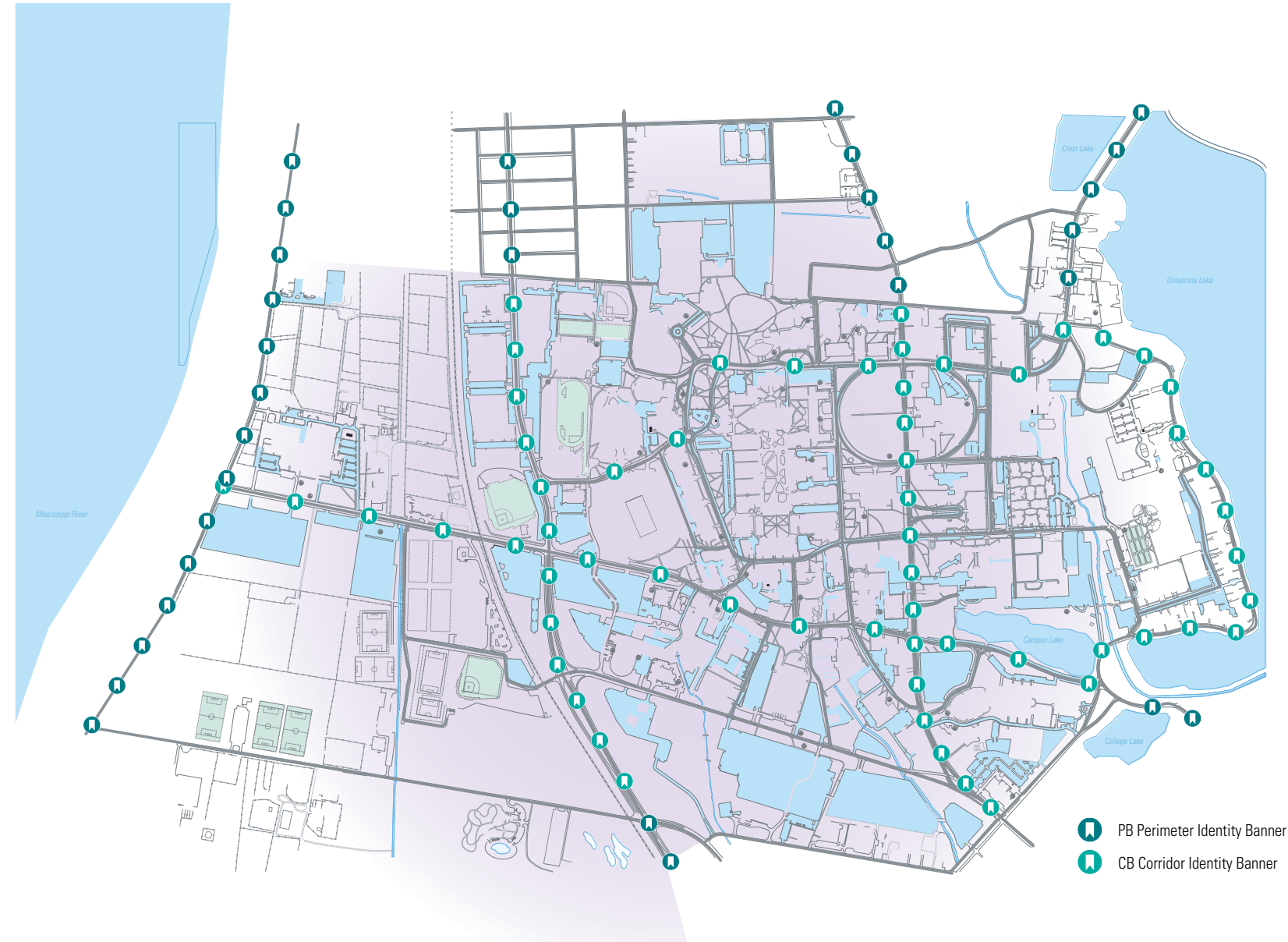

SIGN LOCATION PLAN

INTERPRETIVE STRATEGY

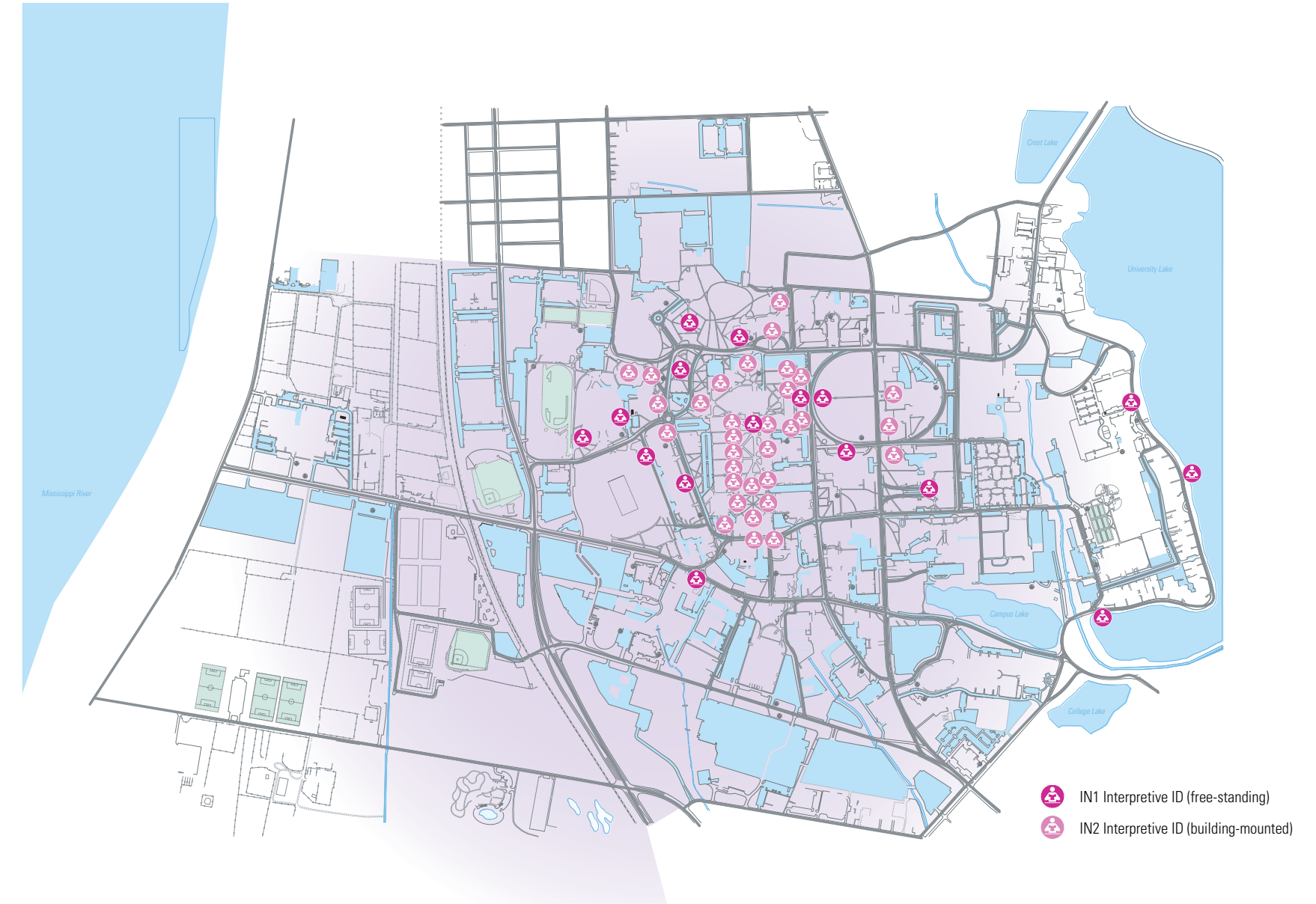

CAMPUS MAP RECOMMENDATIONS

Existing LSU campus maps vary greatly in graphic style, are visually complex, and difficult to update.

Switching to a GIS based mapping system can greatly improve these deficiencies.



Collection of LSU existing campus maps showing the disparity of graphic style



Example of general campus map and attractions map

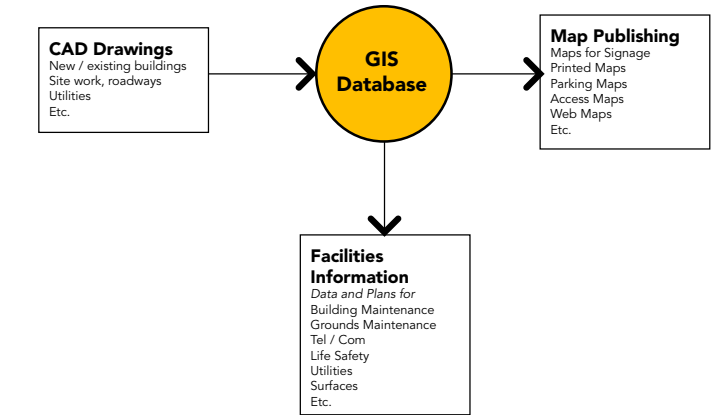

GIS mapping workflow diagram

RECOMMENDATIONS

- Create maps for specific user groups (limiting the amount of information on each map making it easier to understand)
- Use a consistent visual vocabulary
- Add a level of graphic sophistication in order to communicate a professional and appealing presentation to visitors and students
- Design a robust workflow model for LSU updating and printing of maps

PROPOSED MAP TYPES

For web, printed collateral, visitor center hand outs and kiosks

- General Campus Map (Streets and Buildings)
- Parking (All Zones)
- Accessibility
- Visitor Parking Only
- Game Day Parking
- Recreation and Fitness Trails
- Bus Routes and Stops
- Interpretive/ Attractions
- Campus Safety (Night Map w/ lighted walks)
- Enlarged View General Campus Map (for kiosks)
 - Includes GIS data layer for each kiosk location
 - Includes forward-up variations of each map (4 views total)
 - Includes (You are here) and radiating walking distances.
 - Prospective student tour maps
 - Visitor attraction maps

GIS BASED MAPPING SYSTEM

Storing and managing campus map spatial data in GIS provides the following advantages:

- Reduction in expenses associated with updating maps
- (Nearly) Automated map production process
- Enhanced data accuracy through ease of updating
- More accessibility through various desktop and web applications
- Ability to leverage a wide variety of data from various sources
- Many options for developing mapping products



2 SIGN DESIGNS

The components of the sign system were designed individually for optimal functionality while complementing each other in form and finish to create a unified sign family. Signs fall within the following functional categories:

CAMPUS IDENTITY

Signs and structures distinguishing campus edges or entry portals.

VEHICULAR WAYFINDING AND PARKING

Signs serving to direct vehicular traffic to campus as well as within, culminating in a clear system of regulatory parking signs.

FACILITY IDENTIFICATION

Signs identifying the name and address of a building or facility, including building-mounted and freestanding configurations.

PEDESTRIAN WAYFINDING

Signs and maps intended to orient and direct individuals on foot throughout the campus.

ALTERNATIVE TRANSPORTATION

Signs serving the needs of shuttle bus riders or the campus trail network.

EVENT SIGNS

Short-term sign standards.

Renovate, repair, and celebrate

Add subtle LSU identity

Highlight with lighting



Historic Gateways located at Parker and Highland Road



Proposed lighting enhancements at Parker and Highland Road

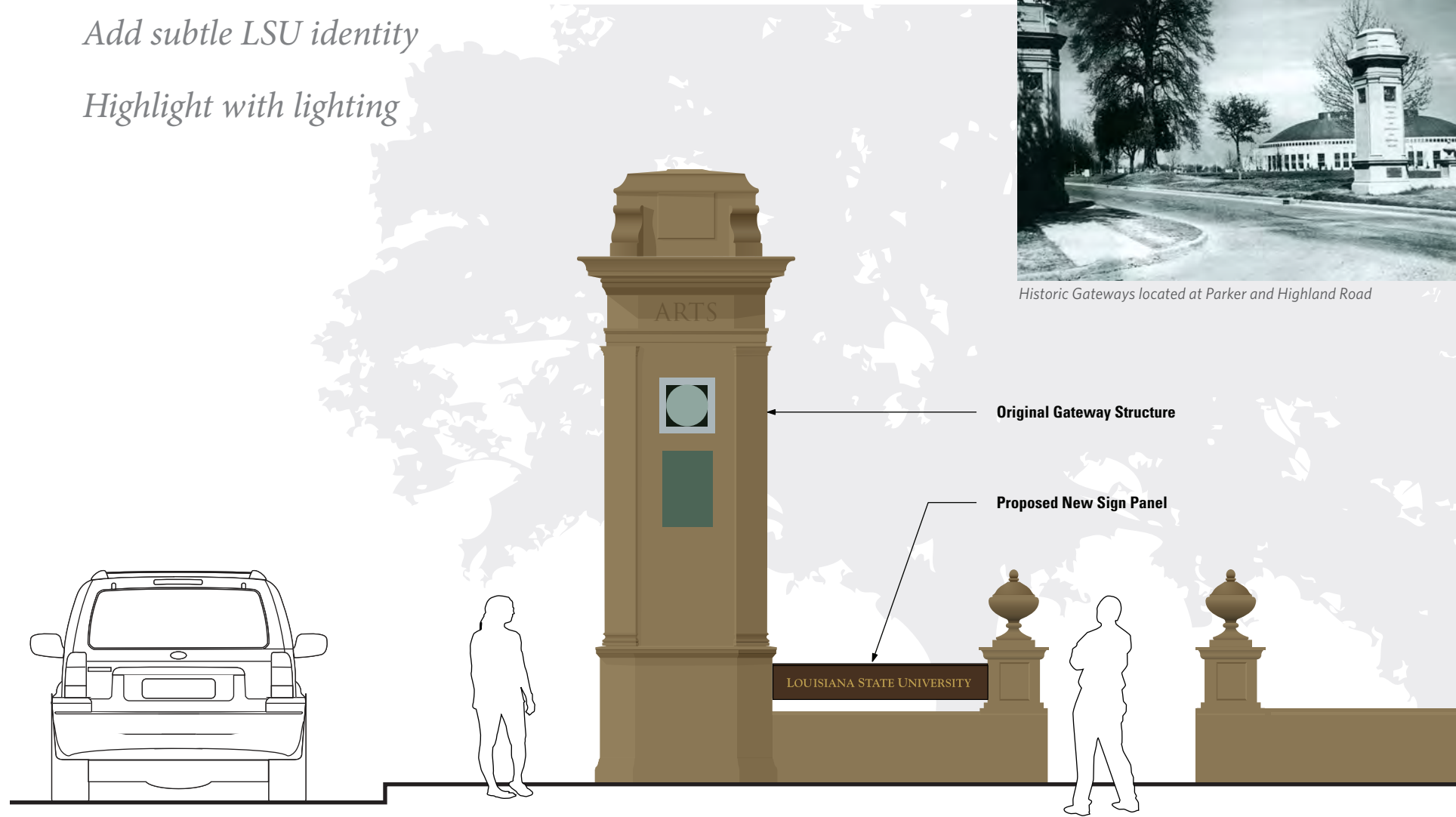

Campus Gateway at Highland Road and Chimes Street

DESIGN RATIONALE

The historic gateways to the LSU campus are distinctive icons, linked to the traditional campus core in design and materials, evoking a gracious, understated sense of entry. The bracketed pairs at either end of Highland Road are appropriately scaled for the two-lane road. The gateway pair at the north campus entry on Nicholson Drive have been diminished by subsequent roadway widening. The gateways are in the process of being repaired, having suffered deterioration over many years. The recommendations are to add LSU identity and directed uplighting in a restrained manner to highlight these one-of-a-kind portals to campus.

MESSAGE CRITERIA

Only the Louisiana State University wordmark text is to be used.

PLACEMENT & ORIENTATION

The gateways will remain in their current locations, with possible expansion of base walls to better engage the sidewalks and additional landscape plantings and ground plane improvement. No effort shall made to replicate or reproduce these anywhere else on campus.

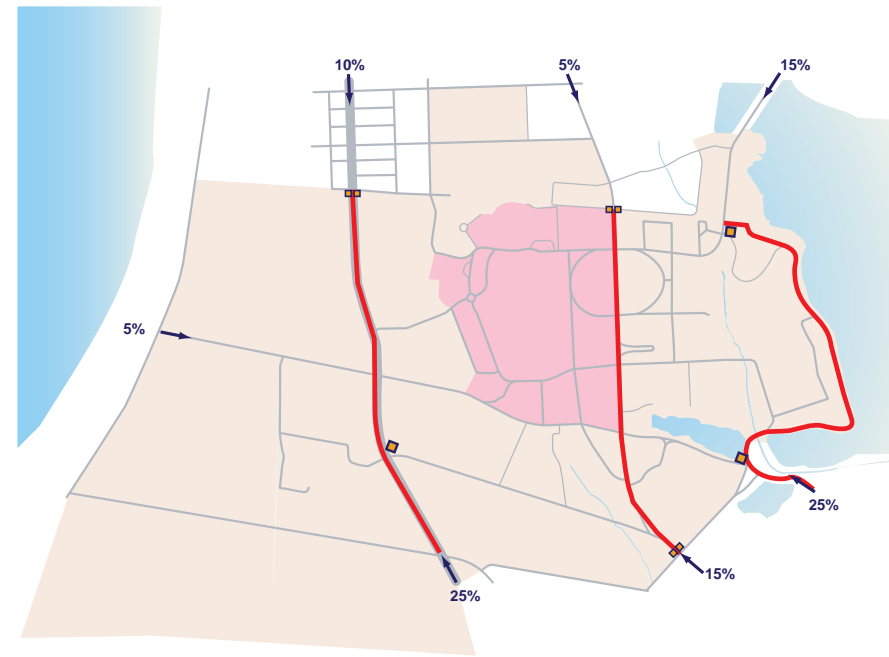

Key Plan: Campus Gateways

- Tier 1: Arteries
- Central Campus (Secure Zone)
- Existing Historic Gateways
- Proposed New Gateways
- ← Percentage of visitors entering campus

Recalls historic gateways

Scale and proportion matches roadway

Preserves views into campus



Proposed Gateway: for South Stadium Drive and Dalrymple entries

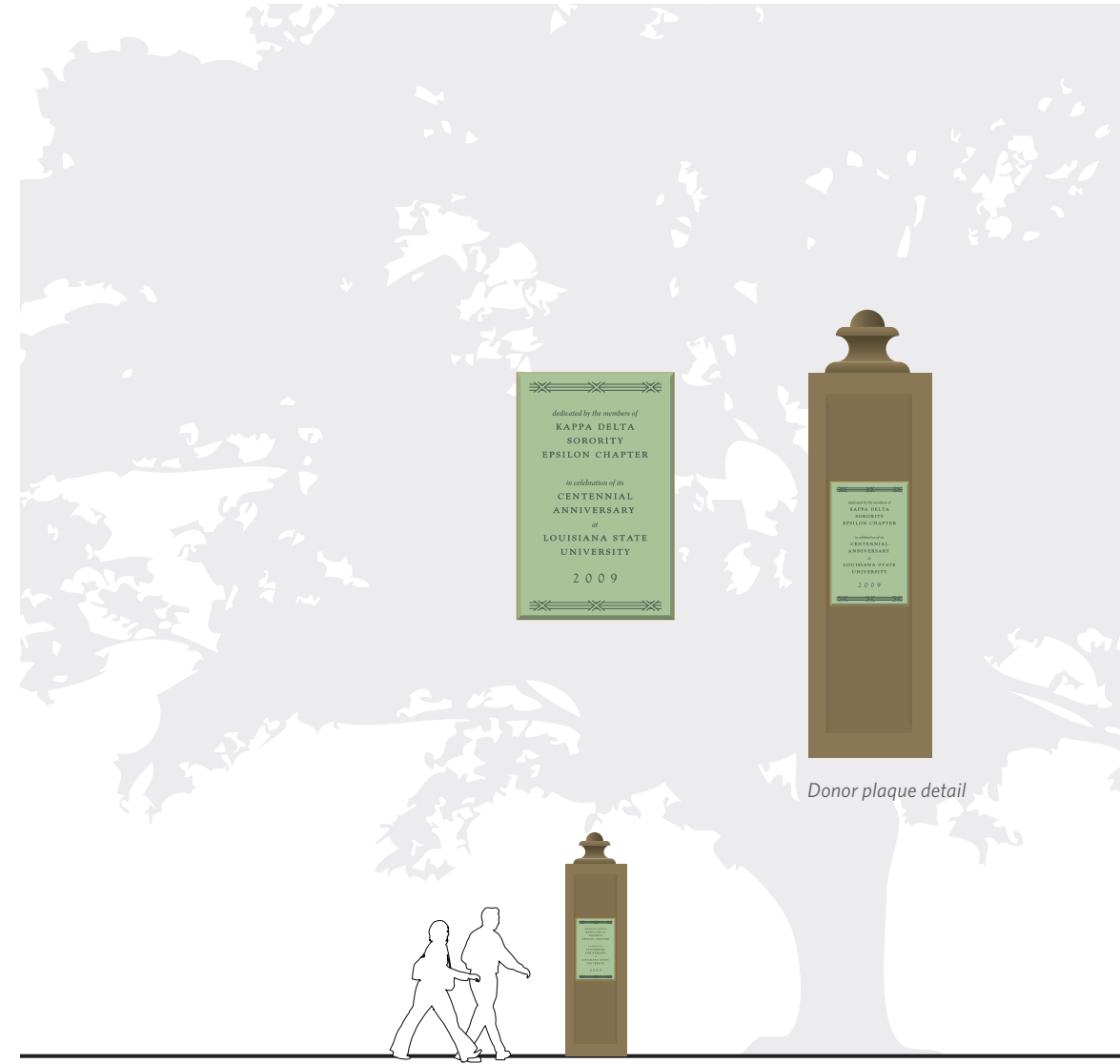

Side view

DESIGN RATIONALE

Over time, entries into the campus have expanded to other portals. Most people arrive to the campus and never pass through the traditional entries of Highland Road. Visitors arrive from the interstate along Dalrymple, from the south along Nicholson Drive, and along West Lakeshore Drive - and none of those entries currently feature LSU identity. The Dalrymple and West Lakeshore entries possess a scale and feel similar to Highland Road, and require appropriately-scaled entry features. The CG-2 gateways are designed to express the spirit and quality of the historic gateways, without copying them, and respond to different approaches and settings. Cast stone, decorative metal and use of the LSU text recall the spirit of the historic campus quad. Soft uplighting will improve nighttime legibility. The gateways are low and open, allowing views over and under into the campus beyond.

MESSAGE CRITERIA

Only the Louisiana State University wordmark text is to be used. Optional donor plaques can be integrated into the piers, providing recognition for groups who choose to assist with the funding and construction.

PLACEMENT & ORIENTATION

The gateways will be designed in conjunction with landscape and roadway improvements at each of the intersections. The complete solution will be a coordinated design of signs, siting, vegetation, lighting and ground plane treatments.

DALRYMPLE AND WEST LAKESHORE DRIVE

PLACEMENT & ORIENTATION

The gateways will be designed in conjunction with landscape and roadway improvements at each of the intersections. The complete solution will be a coordinated design of signs, siting, vegetation, lighting and ground plane treatments.



Daytime composite view: Dalrymple Drive gateway



Plan view: proposed Dalrymple Drive gateway

Incorporate elements of the historic gateways

Appropriately scaled for legibility and context

Full-motion video board for events display

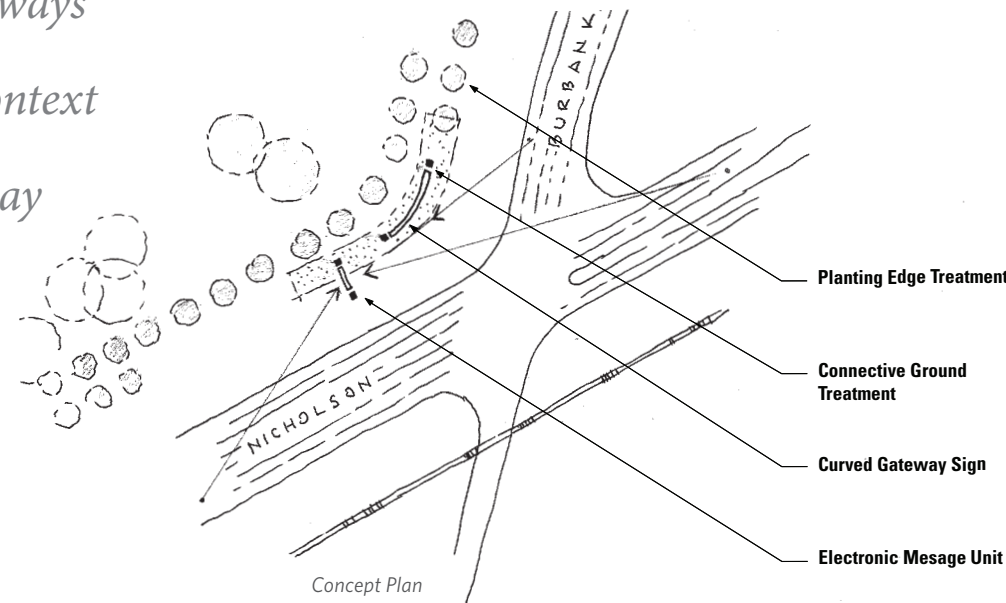

DESIGN RATIONALE

The intersection of Burbank Drive and Nicholson Drive represents the boundary of the main campus. Currently, no formal identifier exists at this location, which happens to be the busiest southern entry to the campus, along the busiest corridor of north-south traffic to and from downtown Baton Rouge and outlying parishes.

Future campus plans call for campus development between Nicholson Drive Extension and Burbank Drive. The new Alex Box Stadium and increasing development in south Baton Rouge will make this corner even more prominent in the future. A new electronic message unit will provide appropriately scaled graphics and event information along Nicholson Drive.

The design challenge is to present an image in keeping with the best of the campus core, at a highway scale, incorporating the motion graphics screen. The proposed design blends these elements into a gracefully curving sign that defines the corner and links to the video screen without being dominated by it. Message context and design for electronic message unit will be developed and administered by the LSU Office of Communications and University Relations.

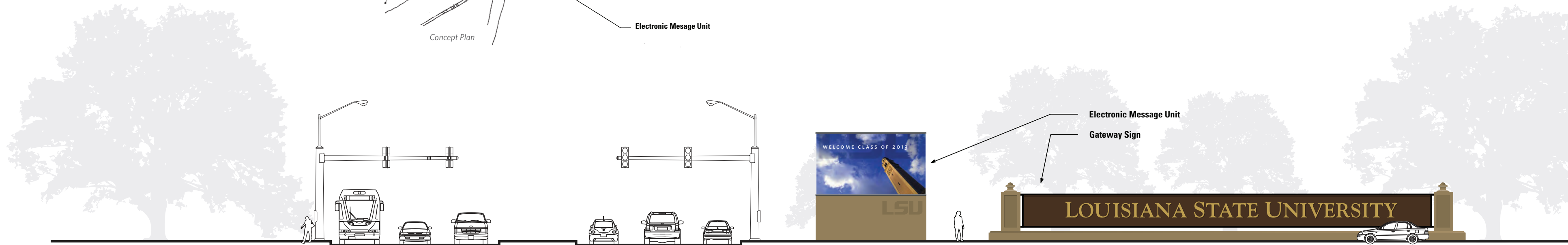

Context elevation: Combined gateway and electronic message unit

Access provided to surface parking for photo opportunities

Ground plane landscape treatment to restrict access

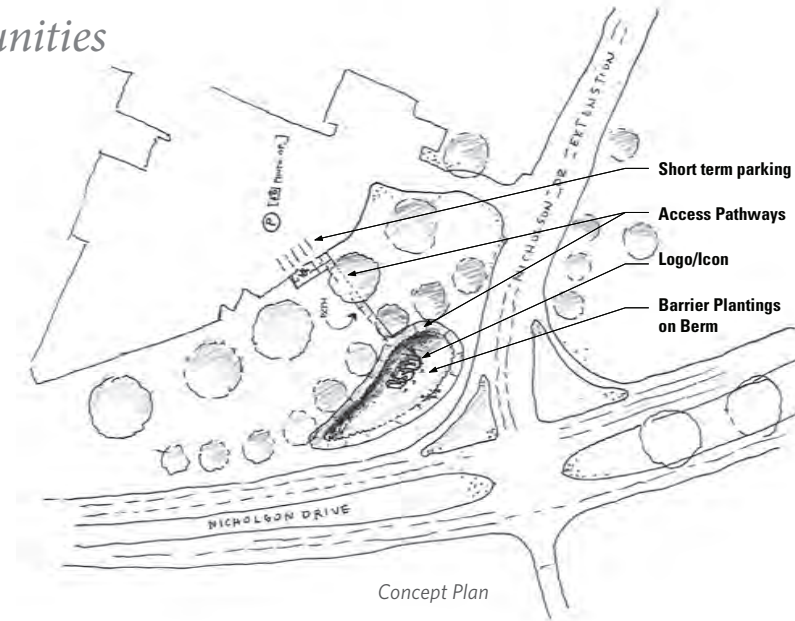

Concept Plan

DESIGN RATIONALE

The intersection of South Stadium Road and Nicholson Drive is both a functional and symbolic entry into the athletic epicenter of the main campus. This is the portal to Tiger Stadium and the PMAC, not to mention the LSU Sports Shop and the Tiger Habitat. The traditional pre-game parade courses down North Stadium Road to the stadium.

The largest number of event attendees arrive from the south, and the largest amount of game-day parking is concentrated to the south. While Tiger Stadium dominates the skyline, there is no street-level affirmation of the LSU campus.

The monumental scaled logo creates a memorable street level icon, heightening the excitement of the gameday experience, and distinguishing this area of campus as the nexus of

athletic activity. More than a gateway, this environmental graphic embodies the spirit of LSU. Access will be provided by a connective pathway from surface parking - providing a venue for memorable photo opportunities. The immediate zone around the logo will be planted with plant species that discourage direct contact or vandalism.



Context elevation



ILLUMINATION

To create a memorable night time presence, several alternatives are being explored for the illumination of the LSU letters:

- Full coverage of letters faces with programmable LED matrix, allowing motion graphics and full video capability (shown at left) Message content and design for LED matrix will be developed and administered by the LSU Office of Communications and University Relations.
- Programmable LED face lighting, projected from ground spotlights, allowing event or seasonal color changes
- Straightforward uplighting from ground spotlights

regional trailblazer

Aids wayfinding for major arteries and exit ramps

Extends LSU identity into community

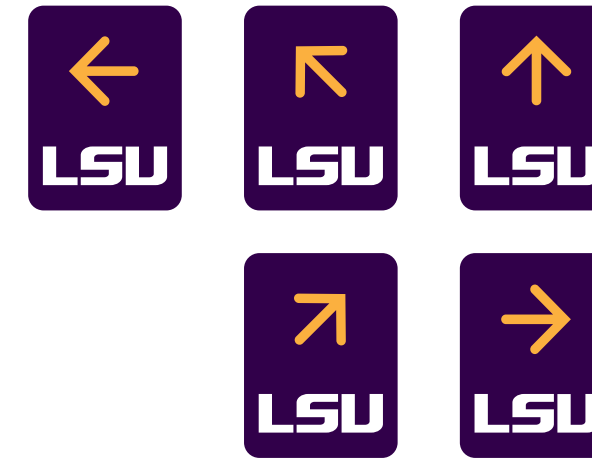

Sign face details

DESIGN RATIONALE

Vehicular trailblazers are intended to reinforce the path of travel for vehicles to the LSU campus along wide, higher speed roadways. Signs are one-sided painted aluminum panel, strap-mounted to an existing pole, or mounted to a single, dedicated, LaDOT-approved sign post.

MESSAGE CRITERIA

Trailblazer sign messages shall consist only of the LSU "Geaux font" logo and the standard directional arrow

PLACEMENT & ORIENTATION

Trailblazers should be located every mile or so, and in advance of major intersections to reinforce the appropriate direction of travel. When meant to indicate a turn, a trailblazer with turned arrow should occur twice—once in advance of the turn and again as close as possible to the turn itself. **Locations will require coordination with City of Baton Rouge and LaDOT for city and state right of ways, respectively.**

Clear and appropriately scaled wayfinding for Nicholson Drive

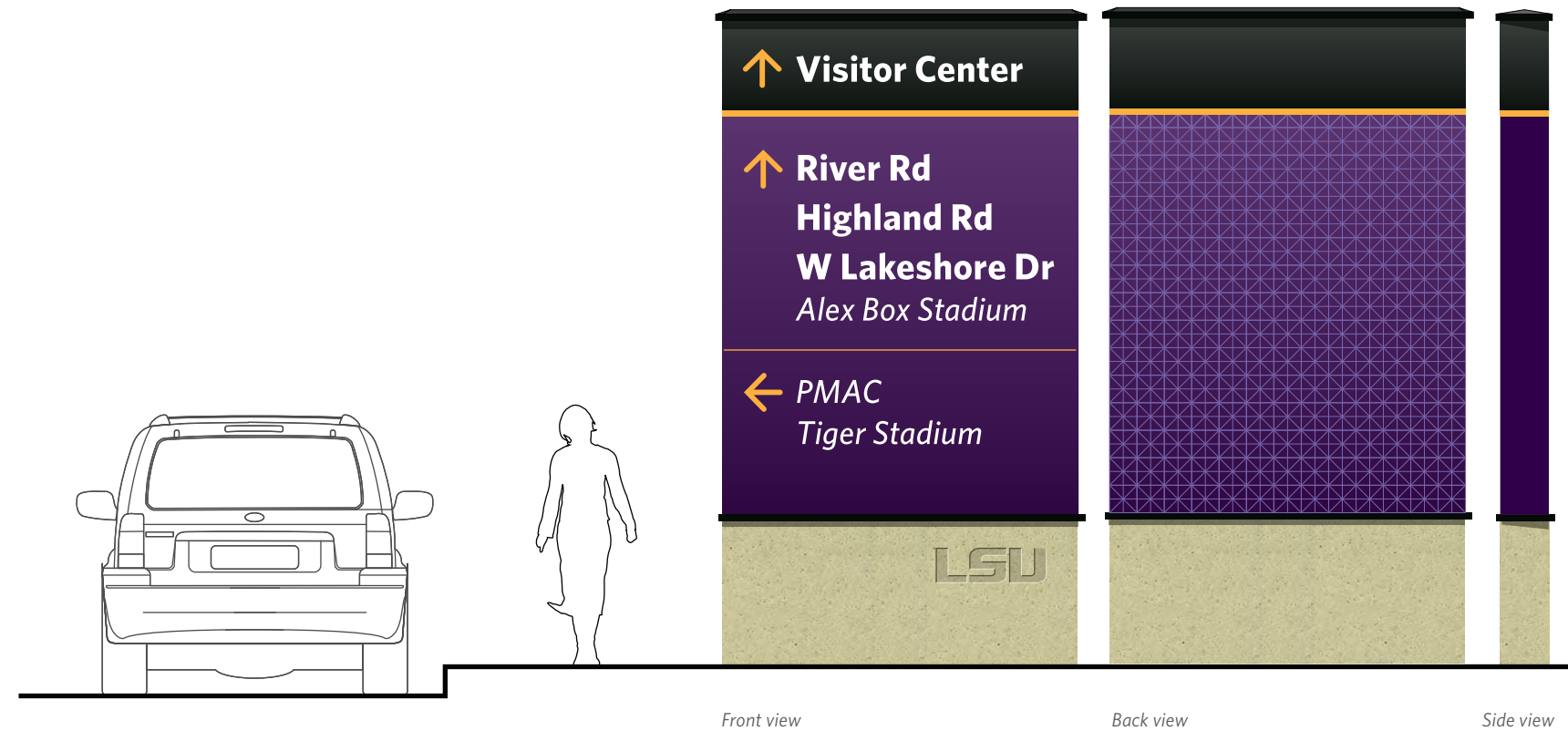

off-campus directional

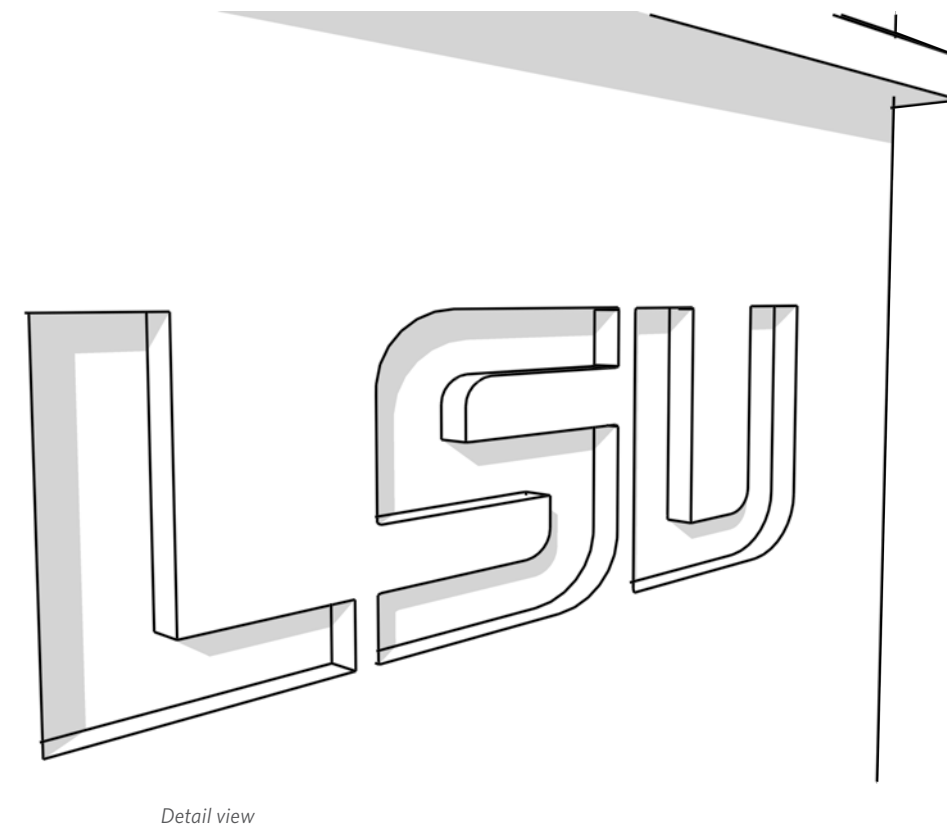

DESIGN RATIONALE

The large vehicular directional is designed primarily for locations along Nicholson Drive (LA HWY 30), a high-speed, multi-lane highway, requiring appropriately sized text height for legibility. The single-sided, fabricated metal signs utilize reflective copy, and have a precast concrete base.

MESSAGE CRITERIA

Sign messages are limited to Tier 1 and Tier 2 destinations.

PLACEMENT & ORIENTATION

Signs should be placed approximately 150 feet in advance of the required turn, set back a minimum of 7 feet from the roadway edge or right of way.

on-campus directional

Clear wayfinding for visitor vehicular traffic

Enduring design and details complement the inner campus experience

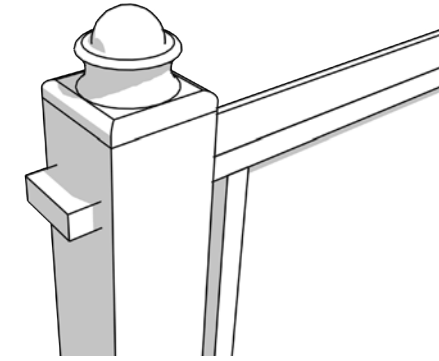
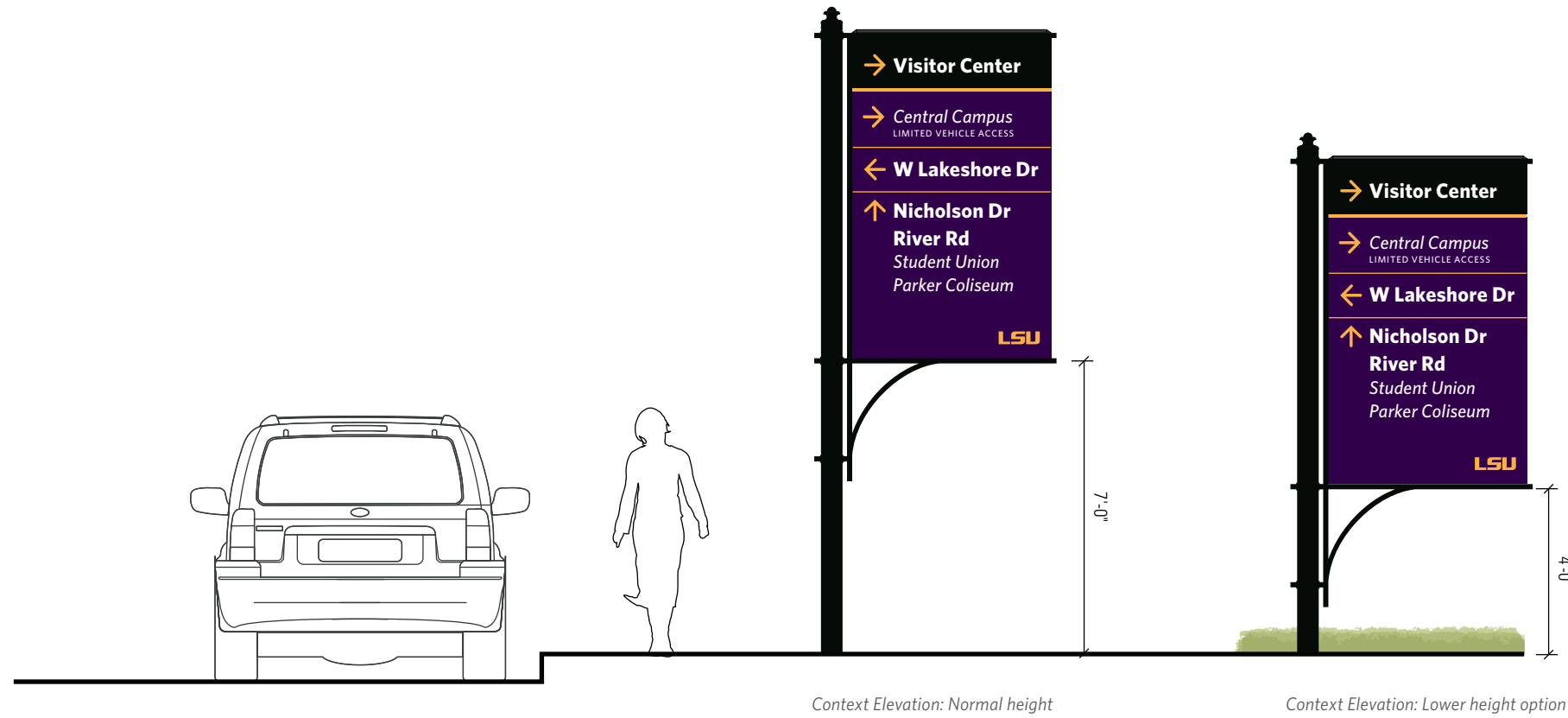

Detail: Finial & post attachment

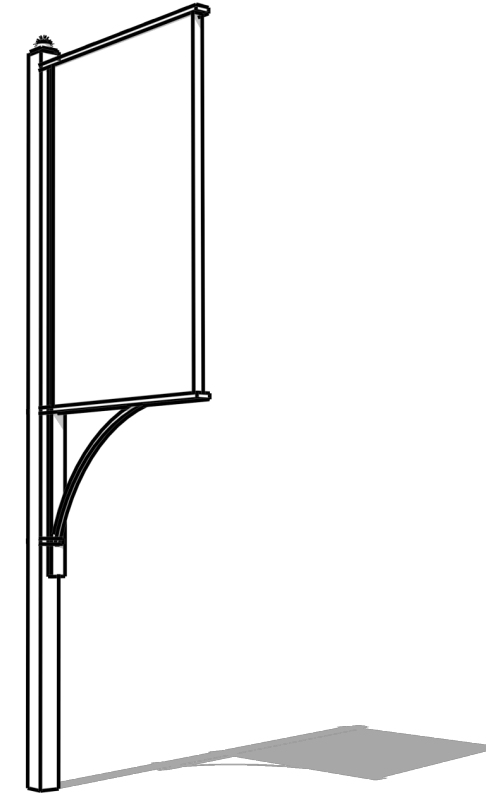

Detail: Isometric view

DESIGN RATIONALE

The campus vehicular directional is designed for lower speed, on-campus roadways. Signs are post mounted, intended to be visible above parked cars, and to not present a visual barrier into the campus at eye level. The single-sided, fabricated metal signs utilize reflective copy and feature removable sign faces for ease of maintenance and updating.

MESSAGE CRITERIA

Sign messages are limited to Tier 1 and Tier 2 destinations.

PLACEMENT & ORIENTATION

Signs should be placed approximately 50 feet in advance of the required turn, set back a minimum of 2 feet from the roadway edge. Final placement should be adjusted to avoid tree canopies, sidewalks, and other landscape features. When lower height option is used, landscape or planting bed must be utilized.

A greeting for visitors, especially when booths are not staffed

Clear explanation of vehicle access and parking policy

Important link in wayfinding strategy

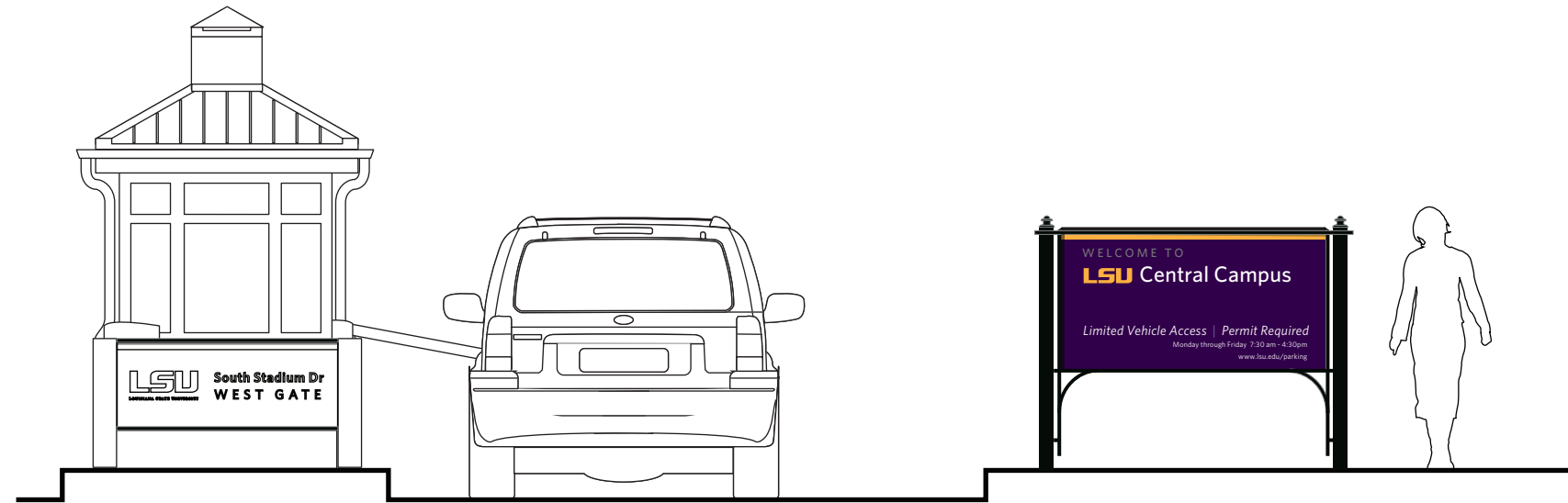

Context elevation



Detail - sign face graphics

DESIGN RATIONALE

The gated entry points to the Central Campus are an important and challenging aspect to vehicular navigation. The Central Campus is also a key destination, and requires identification. Often the control booths are not staffed, and information needs to be provided when the path of travel is blocked. This sign greets and informs visitors with a welcome message, identifies the Central Campus and its car-free status, and describes hours of operation and the permit-only status of parking.

MESSAGE CRITERIA

Signs will identify the Central Campus, and display approved vehicular regulatory and parking restrictions.

PLACEMENT & ORIENTATION

Signs will be located in advance of the control gates and are used in tandem with the booth-mounted entry identification sign, GE2.

Brands entry as LSU

Aids direction-giving by naming gates

Important link in wayfinding strategy

DESIGN RATIONALE

The gated entry points to the Central Campus are an important and challenging aspect to vehicular navigation. Often the control booths are not staffed, and information needs to be provided when the path of travel is blocked. This sign provides a reference point and aids in direction-giving to visitors, service vehicles, and emergency responders.

MESSAGE CRITERIA

Signs will identify the street and the name of the gateway.

PLACEMENT & ORIENTATION

Signs will be attached to gateway booth bollards.



Detail - sign face graphics

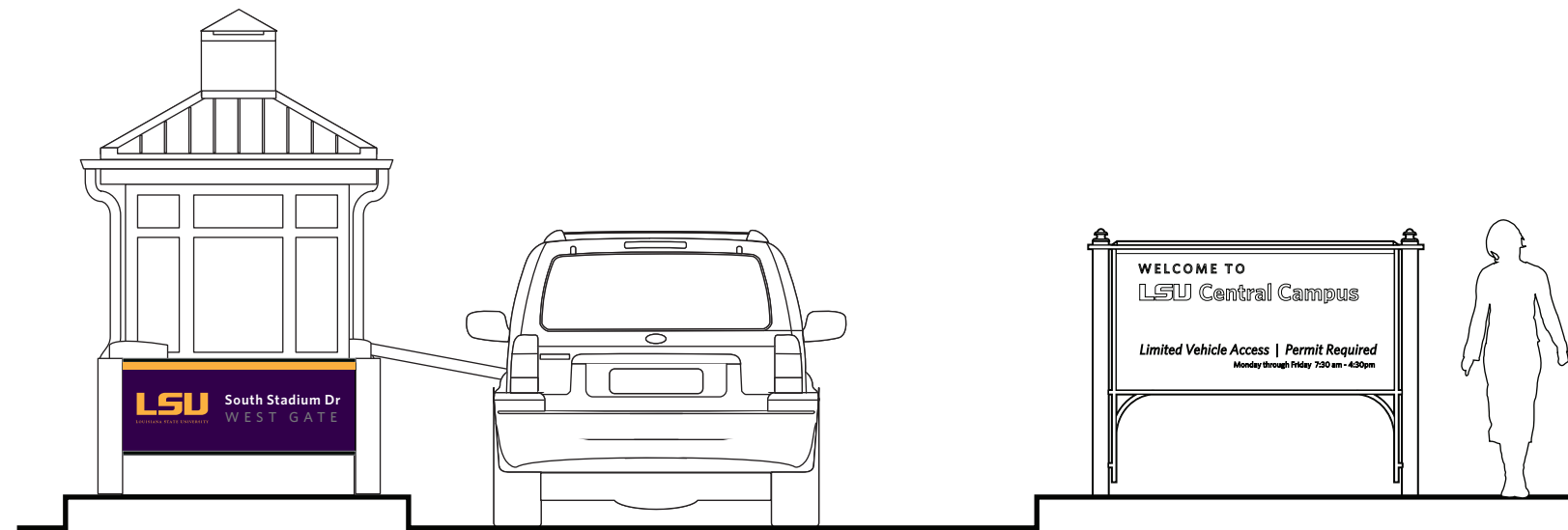

Context elevation

Expression of LSU spirit along key campus roads and edges

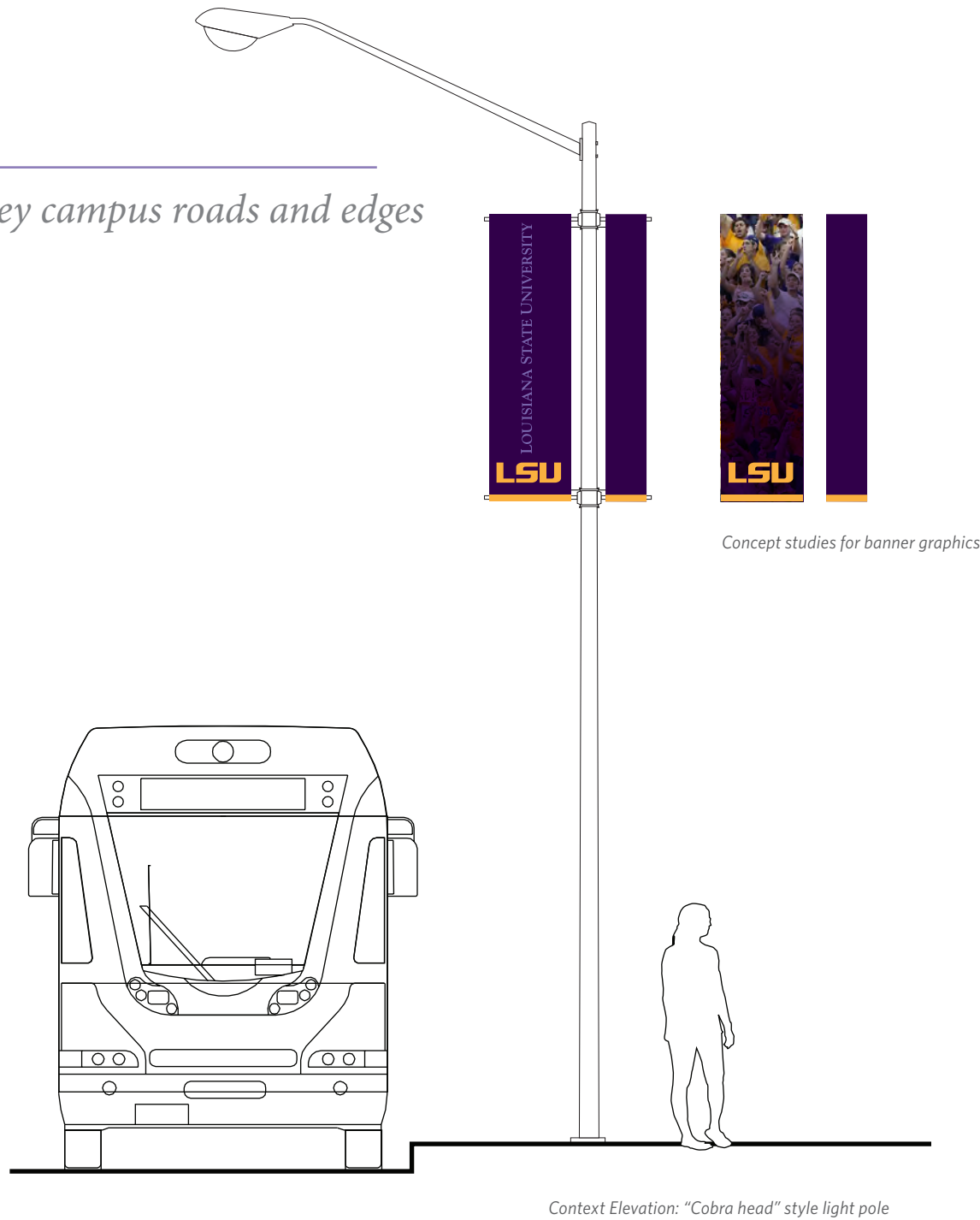

Concept studies for banner graphics

Context Elevation: "Cobra head" style light pole



Concept studies for banner graphics



Context Elevation: Pedestrian scale light poles

DESIGN RATIONALE

Campus banners are intended to bring color and LSU brand presence to the campus perimeter and key interior corridors. Banners are mounted to existing light poles, and scaled appropriately to the size of fixture.

MESSAGE CRITERIA

Banner designs are shown for guidance only as shall be approved through the Office of Communications and University Relations.

PLACEMENT & ORIENTATION

Banners may be placed on the street side of larger fixtures that allow a minimum of 14 feet of clearance. Smaller lighting fixtures dictate sidewalk-side mounting of banners. Street side accent banners maybe used, as long as a clear zone of 18 inches is maintained from face of curb. Banner location strategy is shown on page 20.

parking structure identity

Consistent identification and naming of all structured parking

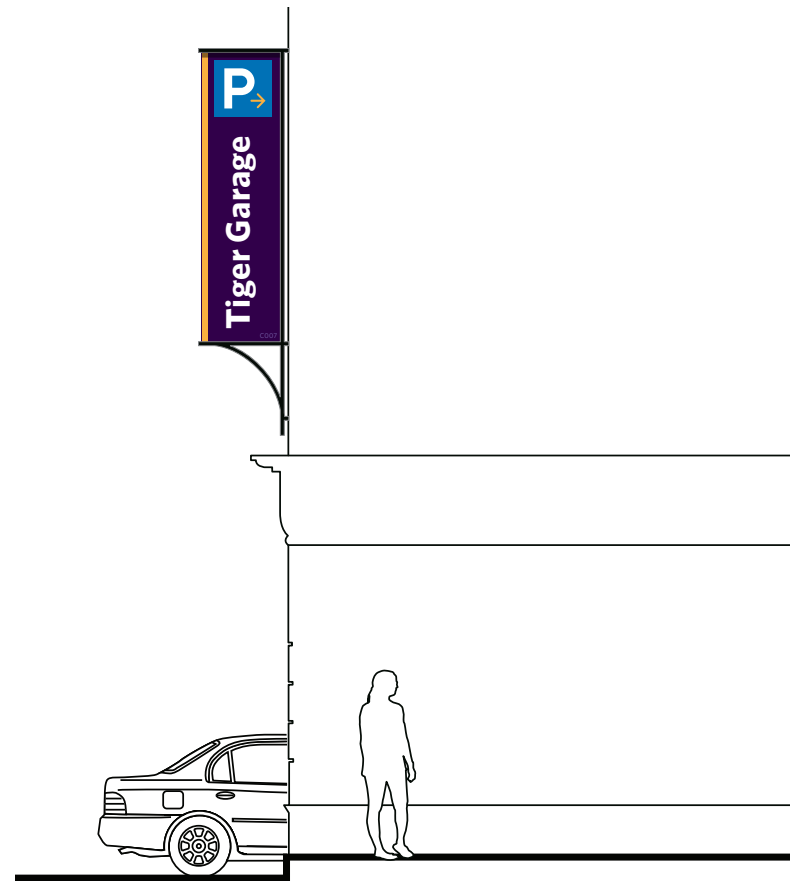

Placement elevation



Context view



Sign face detail

DESIGN RATIONALE

This sign is designed to provide entry identification for large parking structures. The layout illustrated is intended for use at the planned facility on Highland and Raphael Semmes Road. The prominent “P” symbol in a blue square indicates the availability of visitor parking. The large scale and vertical projecting orientation provides visibility for vehicles approaching laterally. The final dimensions and placement of these signs will be coordinated with the design of the individual parking structure.

MESSAGE CRITERIA

Sign messaging is limited to the facility name, parking symbol, and lot number. Where required additional information, such as usage restrictions or hours may be displayed on a companion ground-mounted sign such as Type PK2. This sign will be double-sided, with messages on both sides. Messages will be determined by LSU Office of Facility Development and Campus Planning, and the LSU Office of Parking, Traffic and Transportation.

PLACEMENT & ORIENTATION

The sign is designed for facilities set back from campus roadways, necessitating a projecting mount on the structure facade, intended to be visible for vehicles approaching from left or right. Final placement will be determined based upon the approved garage design.

Consistent naming of all surface parking lots

Consolidated restriction information

Incorporation of temporary event panel



Message Options: Visitor parking available

Restricted parking only

Event restriction panel



Sign face detail

DESIGN RATIONALE

The PK series of signs consolidates and organizes parking lot naming, restrictions, visitor parking availability, and LSU Parking Department tracking numbers into one consistent sign for use at the entrances to surface lots. A removable panel accommodates special event parking designations.

MESSAGE CRITERIA

Sign messaging is limited to the facility name, visitor parking messaging, usage restrictions/hours of operation and lot number. Messages will be determined by the LSU Office of Facility Development and Campus Planning, and the LSU Office of Parking, Traffic and Transportation.

PLACEMENT & ORIENTATION

For maximum legibility, this sign is recommended to be double sided and placed perpendicular to the main campus roadway. Optionally, signs may be single-sided and faced parallel to campus streets, depending on approaches and viewing angles. Final locations will be determined by the LSU Office of Facility Development and Campus Planning.

parking identity

RESTRICTED, ON-STREET PARKING

Minimize sign clutter

Standardized pole, hardware and graphics



Sign face details



DESIGN RATIONALE

This sign is designed to provide clear identification of on-street campus parking and consistent posting of parking restrictions and hours of operation.

MESSAGE CRITERIA

Messages and parking zones will be determined by LSU Office of Facility Development and Campus Planning, and the LSU Office of Parking, Traffic and Transportation.

PLACEMENT & ORIENTATION

The sign is typically set close to the roadway, with a minimum distance of 18 inches to the face of the curb. The sign is single-sided, with the message face parallel to, and oriented towards the street. Signs will be used in pairs, bracketing the parking zone. Additional mid-zone signs may be used to further define longer parking areas.

special parking

RESTRICTED PARKING

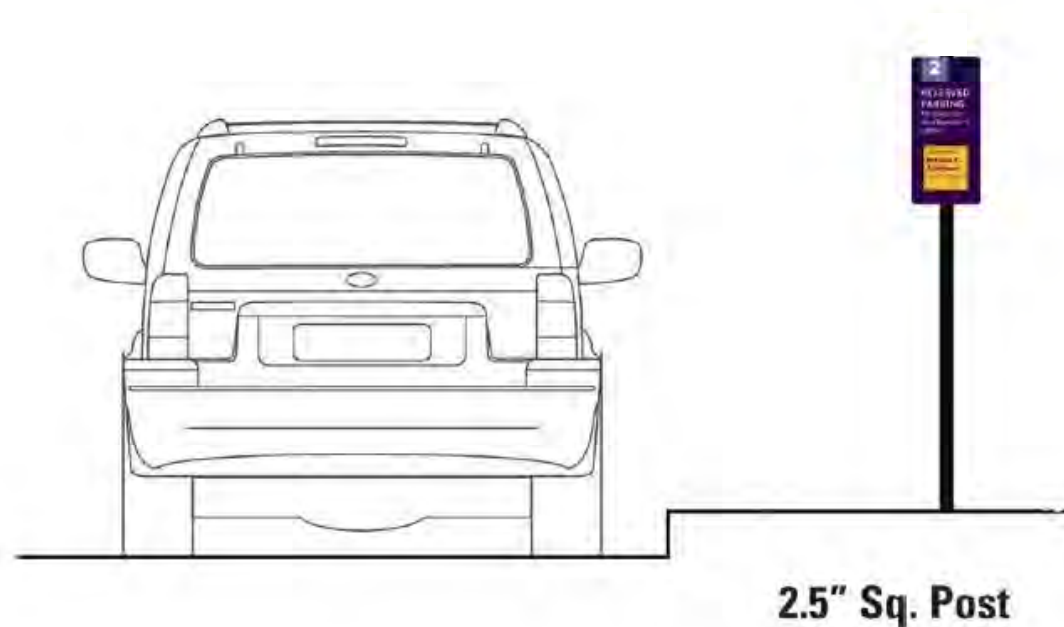

DESIGN RATIONALE

This sign is exclusive to "D" parking spaces, reserved visitor parking spaces, and accessible parking spaces. On the "D" parking spaces, the yellow panel shall be attached to the frame with tamper proof screws. On the reserved visitor parking spaces, the yellow panel is a laminated insert. The sign panel requires a frame for the insert. On the accessible parking spaces, no frame or insert is required.

MESSAGE CRITERIA

The illustrated templates dictate the color, placement, and color emphasis of information on the sign panel. Official messaging will be generated by the LSU Office of Parking, Traffic, and Transportation in conjunction with LSU Office of Facility Services Planning, Design, and Construction Group.

PLACEMENT & ORIENTATION

The sign is typically set close to the roadway, with a minimum distance of 18" to the face of curb. The sign is single-sided, with the message face parallel to and oriented towards the street. Signs will be freestanding and located at each designated "D" parking space, reserved parking space, or accessible parking space.

special parking

RESTRICTED PARKING

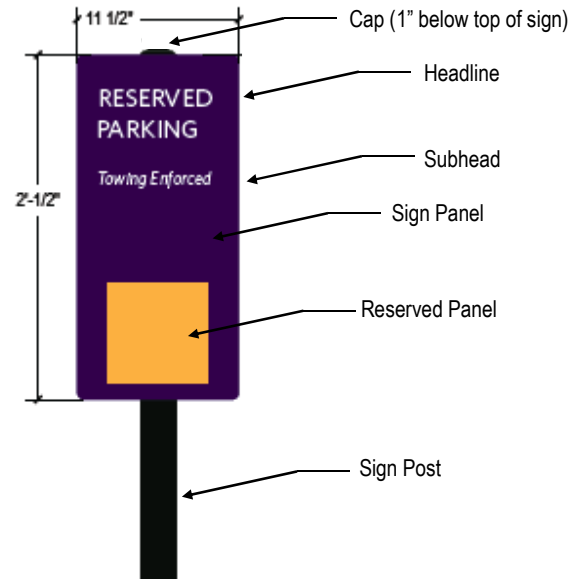

FABRICATION DETAILS

- Cap: cast aluminum or approved equal, AP3
- Headline: 1/4" h., V2, T2
- Subhead: 7/8" h., V2, T3
- Sign Panel: 1/8" aluminum panel, AP1 (front), AP3 (back)
- Reserved Panel: 7" x 7" x 1/4" aluminum panel, AP2
- Sign Post: 2.5" sq. aluminum extrusion, AP3

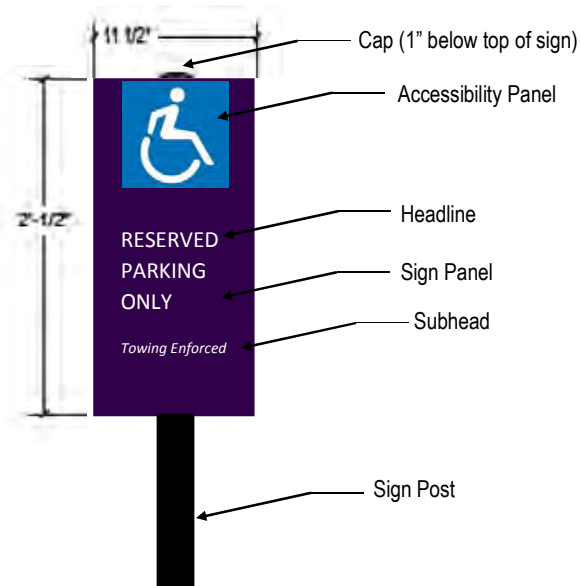

FABRICATION DETAILS

- Cap: cast aluminum or approved equal, AP3
- Accessibility Panel: 6" x 6", V2, V6
- Headline: 1/4" h., V2, T2
- Sign Panel: 1/8" aluminum panel, AP1 (front), AP3 (back)
- Subhead: 7/8" h., V2, T3
- Sign Post: 2.5" sq. aluminum extrusion, AP3

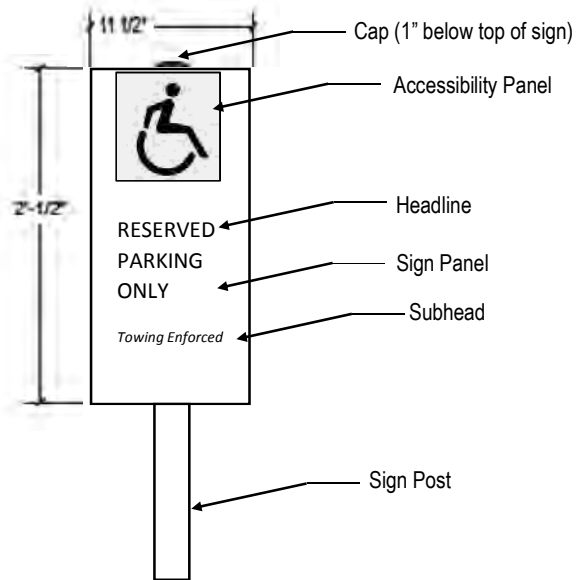

FABRICATION DETAILS – PK4a

- Cap: cast aluminum or approved equal, AP3
- Accessibility Panel: 6" x 6", V2, V6
- Headline: 1/4" h., V2, T2
- Sign Panel: 1/8" aluminum panel, AP1 (front), AP3 (back)
- Subhead: 7/8" h., V2, T3
- Sign Post: 2.5" sq. aluminum extrusion, AP3

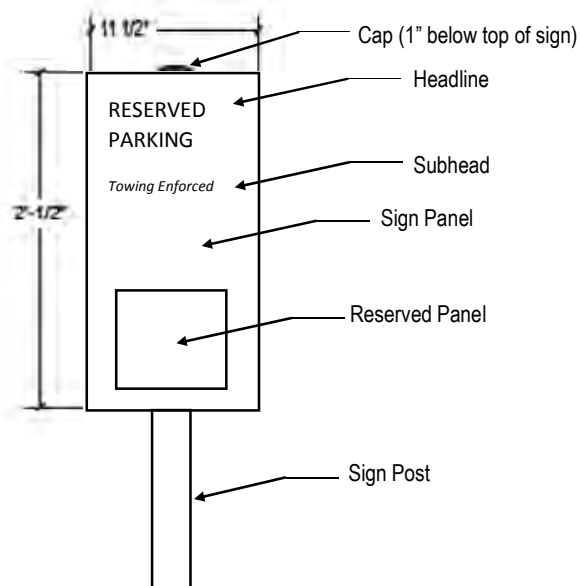

FABRICATION DETAILS – PK4b

- Cap: cast aluminum or approved equal, AP3
- Headline: 1/4" h., V2, T2
- Subhead: 7/8" h., V2, T3
- Sign Panel: 1/8" aluminum panel, AP1 (front), AP3 (back)
- Reserved Panel: 7" x 7" x 1/4" aluminum panel, AP2
- Sign Post: 2.5" sq. aluminum extrusion, AP3

Consolidates and streamlines campus-wide parking signs

Dramatic reduction in “sign pollution”

Consistent policy language to aid enforcement



Detail - layout templates

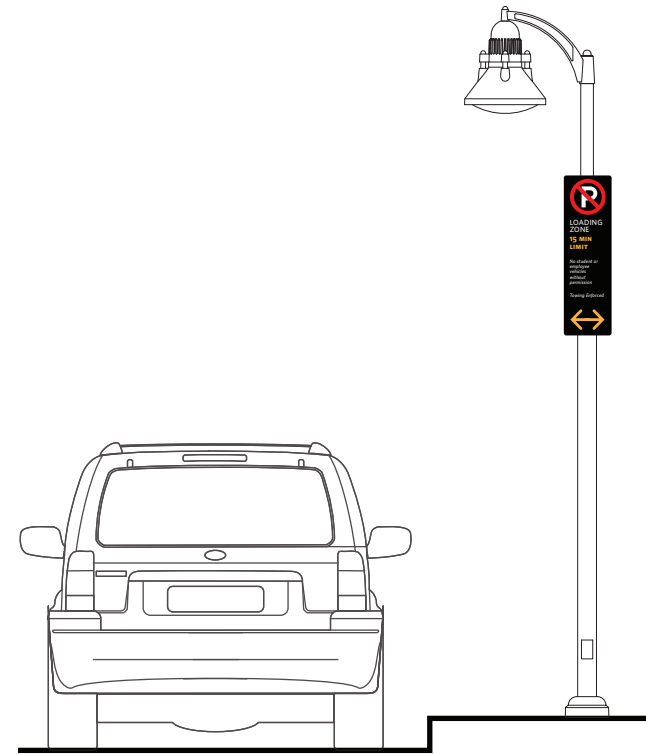

Context elevation



Context elevation

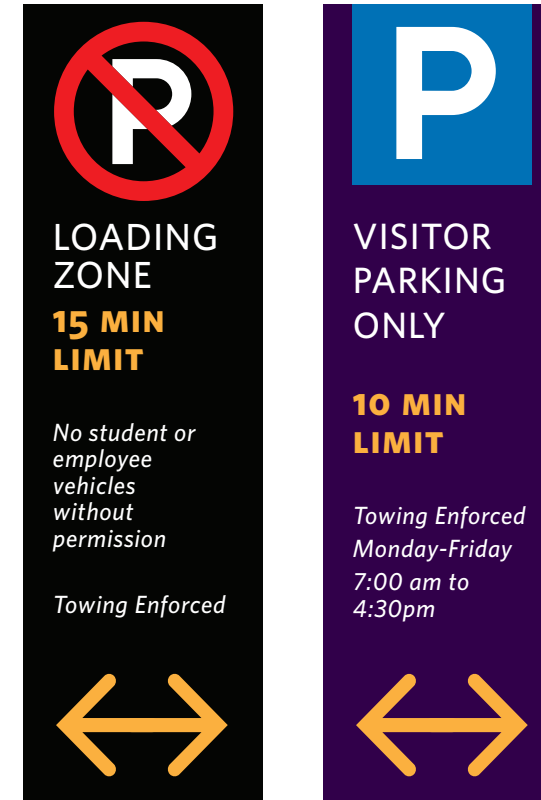

Detail - sign face graphics

The headline message is the primary parking information and relates directly to the symbol—this message should be consistent for all signs displaying a given symbol. Body text elaborates on hours of enforcement, special permit requirements, and the like.

The subheading text is used to communicate enforcement when there is additional content beyond what the body text will accommodate.

A single arrow is used on a sign located on the left or right end of a range of spaces to which identical regulations apply. If the range contains more than four spaces, a double arrow should be used on a single sign centered between the two ends, or on several signs located at even intervals. A sign with no arrow is appropriate for identifying a single space. Accessible parking and visitor parking spaces should always be identified individually.

DESIGN RATIONALE

The posting of campus parking zones and regulatory information has been consolidated and organized into a single template system of uniform design and size. The net result will be a reduction in the number and variety of signs on campus. Combined with the upgrade in post hardware, the overall level of sign pollution and confusion over parking restrictions will be greatly reduced.

MESSAGE CRITERIA

The illustrated templates dictate the order, placement, and color emphasis of information on the sign panel. Official messaging will be generated by the LSU Office of Parking, Traffic, and Transportation.

PLACEMENT & ORIENTATION

The sign is typically set close to the roadway, with a minimum distance of 18” to the face of the curb. The sign is single-sided, with the message face parallel to, and oriented towards the street. Signs may be freestanding or attached to existing poles.

Consolidates and streamlines campus-wide traffic regulatory signs

Improves the quality of the campus landscape

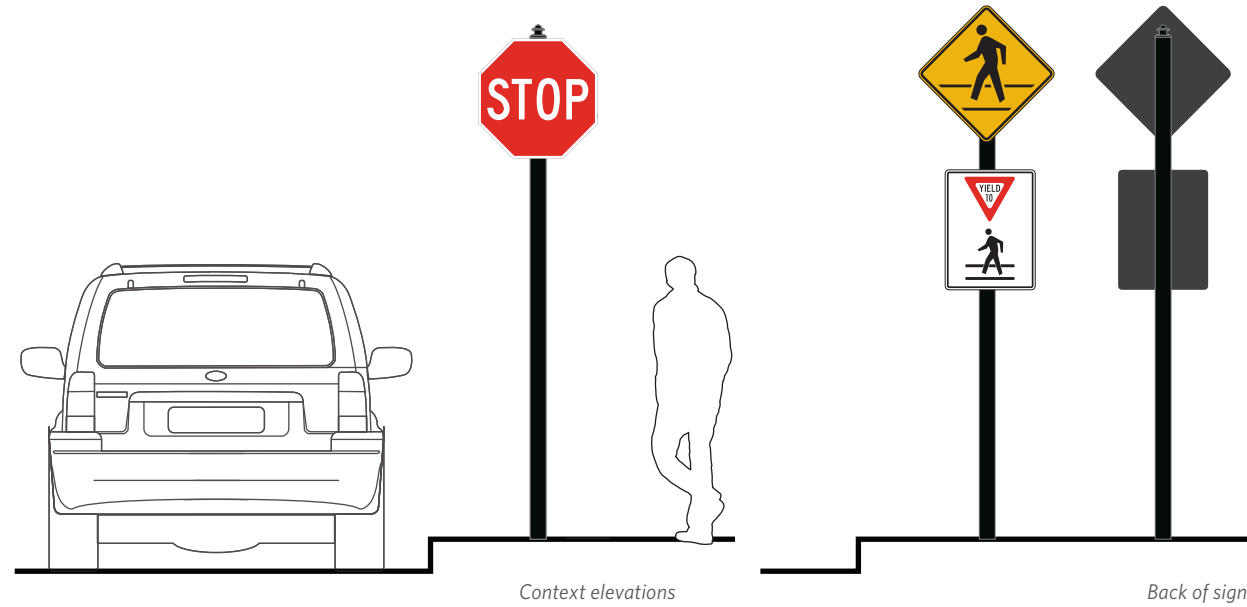

Detail - sign face graphics

DESIGN RATIONALE

Basic traffic control signage will be displayed on a simple black metal square post. This simple upgrade will unify the appearance and quality of this basic sign type, and minimize the clutter of mixed hardware styles. Backs of signs will also be painted, reducing the prominence of regulatory sign posting in the landscape.

MESSAGE CRITERIA

Sign face graphics will be retro-reflective, with panel shapes, messages, colors and symbols in compliance with the current edition of the MUTCD.

PLACEMENT & ORIENTATION

Sign panels should be positioned a minimum of 18 inches from face of curb, with a minimum distance of 7 feet from the bottom of the sign to the ground. Signs may be directly buried, with below-grade poured-in-place concrete footings, and LADOT-approved breakaway couplings.

Street names are a key component of overall wayfinding strategy

Responds to future building addressing and emergency response requirements

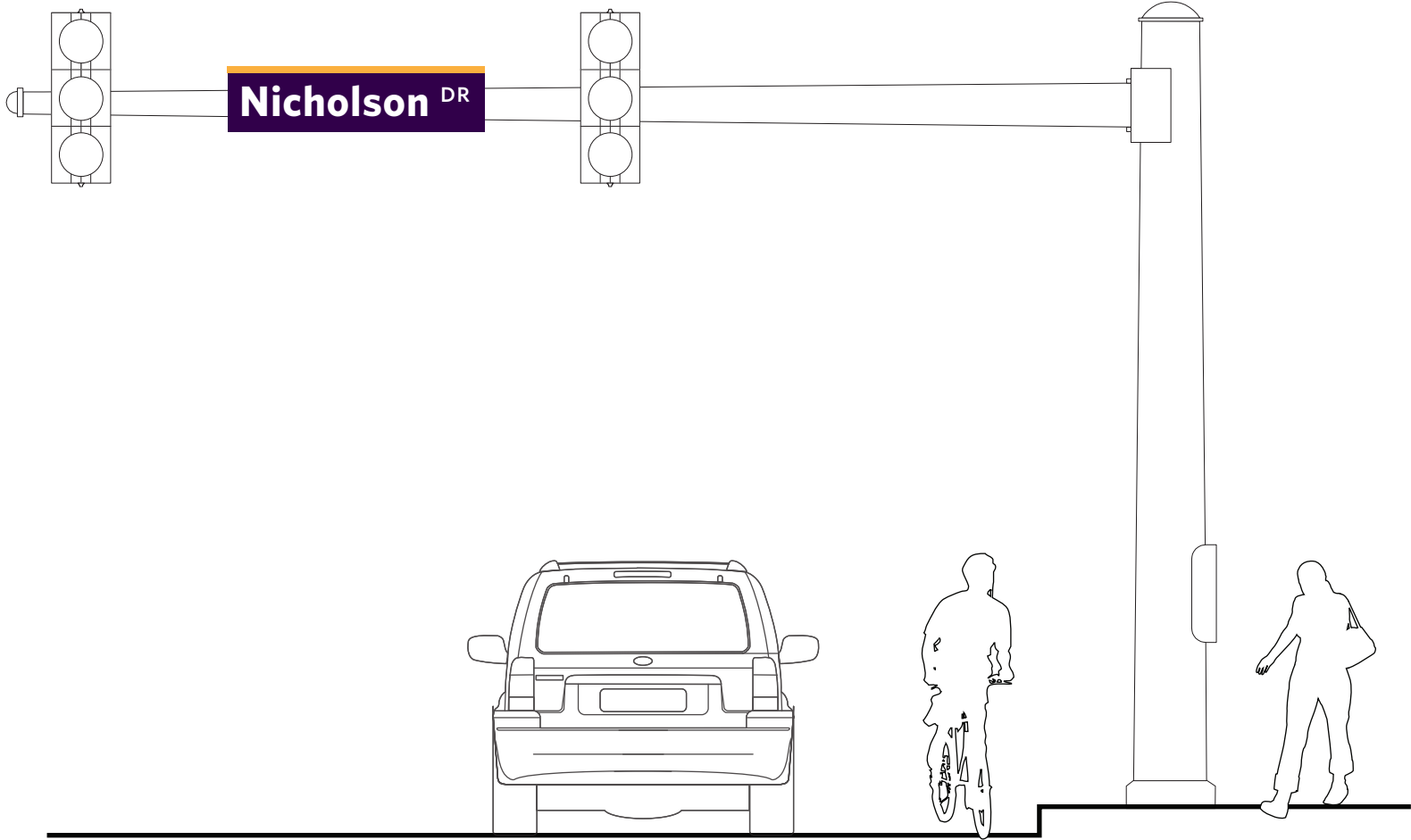

Context elevation: Mast arm mounting



Sign face detail

DESIGN RATIONALE
 LSU street signs will stand out from the standard sign designs, with their unique color scheme and type style. Through their repetitive use, custom street signs are an effective way to define a campus district and reinforce the LSU identity. Three sizes of street signs have been developed that respond to various roadway scales and speeds. The largest, shown here, is specifically designed for Nicholson Drive. This sign may be used along other large perimeter roadways as the campus expands.

MESSAGE CRITERIA
 Messages will comply with City of Baton Rouge and LADOT official street name nomenclature.

PLACEMENT & ORIENTATION
 Signs are typically located on traffic control crossarms, parallel to the identified cross street, facing traffic, visible from stop lines. **Application, approval and locations shall be coordinated with City of Baton Rouge and LADOT.**

Distinctive bracket and hardware evokes historic campus core

Reinforces LSU brand

Creates distinctive campus district

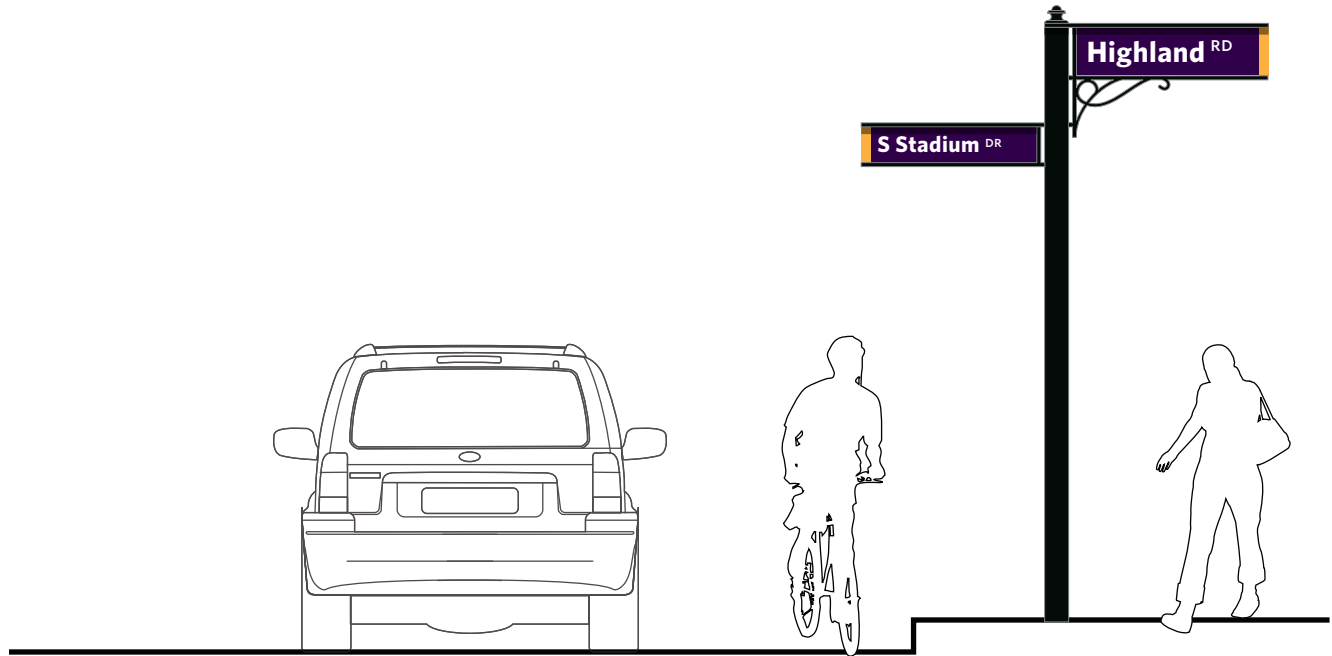

Context elevation: PK2 and PK3 mounted in combination



Sign face and post detail

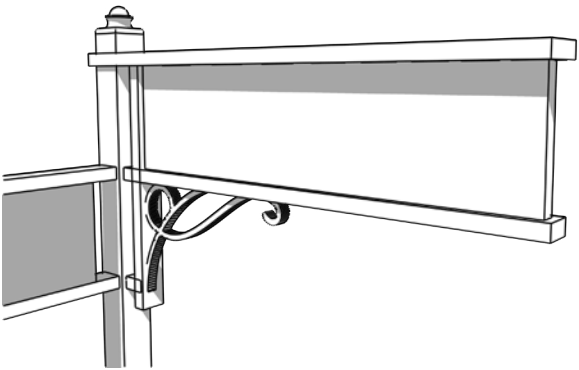

Assembly and configuration detail

DESIGN RATIONALE

The larger letters and decorative scrollwork identify significant interior campus roadways. The 6" inch letter height is designed for legibility at posted speeds greater than 25 MPH. The larger sign blade may be combined with the 4 inch version where intersections with secondary streets on the same post occur.

MESSAGE CRITERIA

The 6 inch street sign is designated for the following roadways:

- Lakeshore Drive
- Highland Road
- South Stadium Drive
- Nicholson Extension

Panel length is determined by message length.

PLACEMENT & ORIENTATION

Locate street signs on opposite corners of the intersection of all named streets for wayfinding and emergency response purposes. Leading edge of signs must be set back at least 2 feet minimum from front of curb, and blades should point away from the intersection.

Creates distinctive campus district

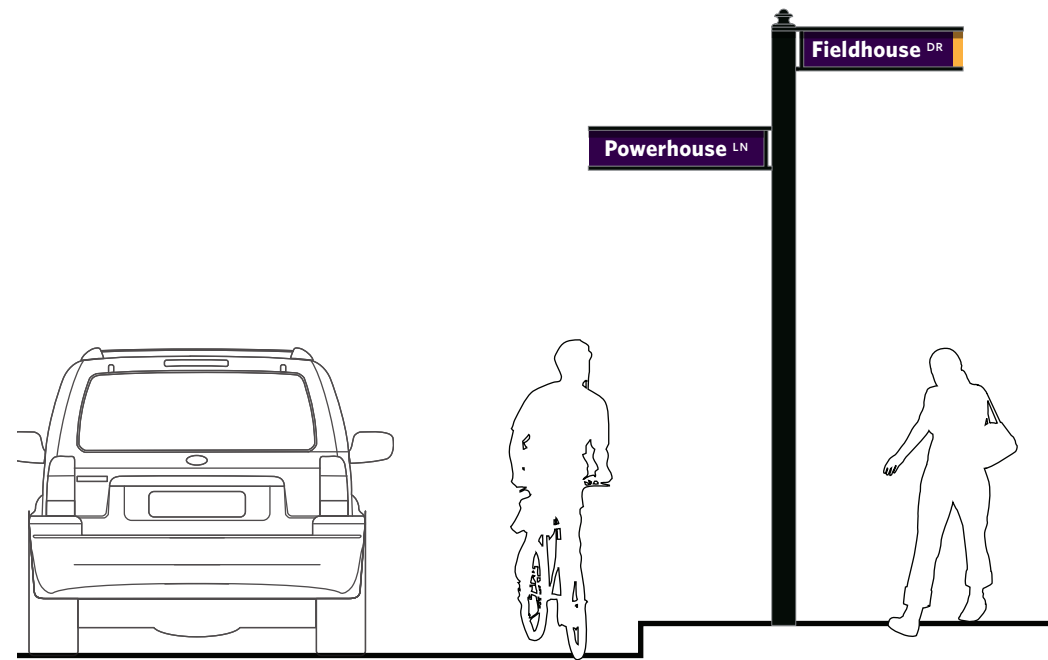

Context elevation

SN3

street name

SECONDARY CAMPUS ROADWAYS

DESIGN RATIONALE

This sign is intended to be the primary street sign for the interior campus. The 4 inch letter height street sign is designed for legibility at posted speeds 25 MPH or less. The 4 inch sign blade may be combined on the same post with the larger 6 inch version where intersections with primary streets occur.

MESSAGE CRITERIA

The 4 inch street sign is designated for all campus roadways with the exception of those identified with SN1 or SN2 signs. Panel length is determined by message length.

PLACEMENT & ORIENTATION

Locate street signs on opposite corners of the intersection of all named streets for wayfinding and emergency response purposes. Leading edge of signs must be set back at least 2 feet minimum from front of curb, and blades should point away from the intersection.



Sign face detail

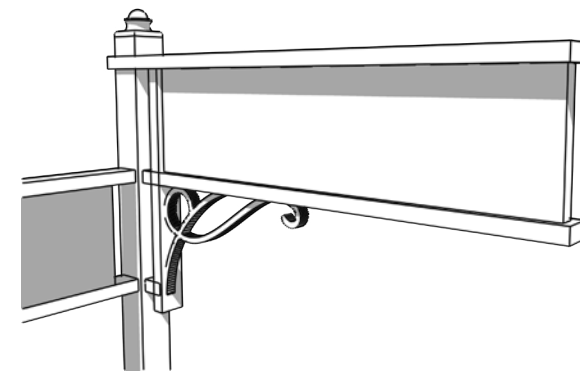

Assembly and configuration detail

facility identity

VEHICULAR-SCALED

Consistent, legible facility identification, for vehicles and pedestrians

Standardized building names across campus

Allowance for major affiliate branding (AgCenter, Law Center)

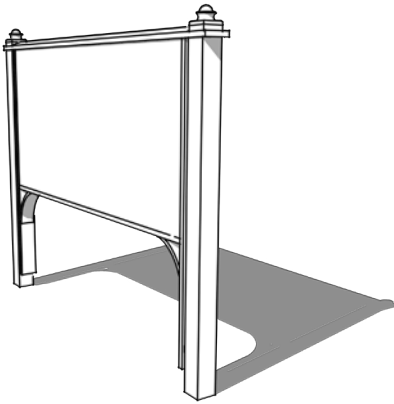

Isometric view

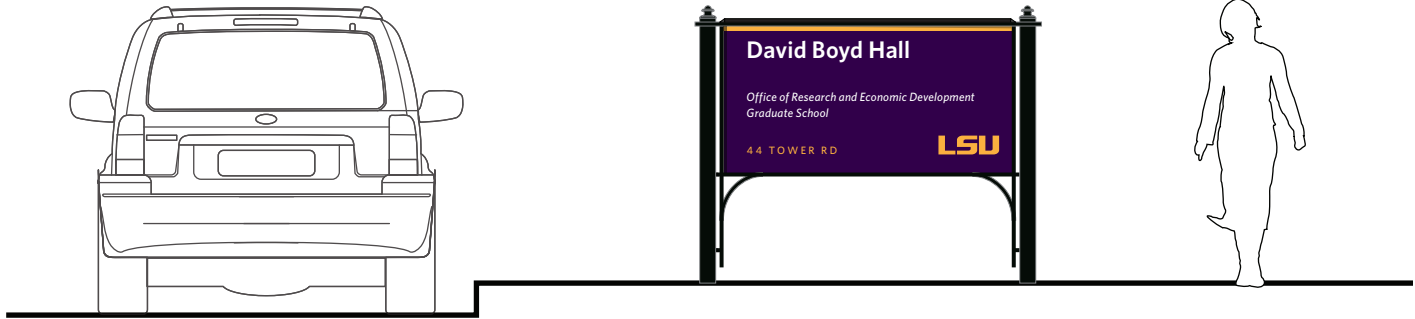

Context elevation



Standard sign face layouts



Layouts with permitted affiliate logos



DESIGN RATIONALE

Primary main campus facility identification, scaled to be legible from vehicles. Sign is non-illuminated, with messages occurring on both faces. Buildings with multiple entrances, and entrances with strictly pedestrian approaches, may use FA1 and FA2 (smaller scaled) signs in combination.

MESSAGE CRITERIA

Identification will be restricted to the official building name, building construction date, street address, and LSU logo. A single department or school generating high levels of visitor traffic may be included, based on written approval from the LSU Office of Finance and Administrative Services (FAS). LSU Law and Ag Center are permitted to use their affiliate logo in a single color (gray) in place of the LSU logo. Use of the affiliate logos shall be restricted to buildings that are either 100% or “mostly” occupied by the respective affiliate. A site plan diagramming LSU Law and Ag Center campus facilities can be found in the Appendix. All FA1 signs shall be reviewed and approved by the LSU Offices of Facility Development and Campus Planning.

PLACEMENT & ORIENTATION

Signs are generally oriented perpendicular to roadways for best visibility, and should be consistently set back from the sidewalk edges. Signs should ideally be placed in planting beds to minimize obstruction to mowing and potential damage. Straightforward, direct burial, is preferred, thereby concealing exposed concrete footings.

facility identity

PEDESTRIAN-SCALED

For pedestrians, consistent facility wayfinding and identification

Scale and detailing that respects the historic campus core

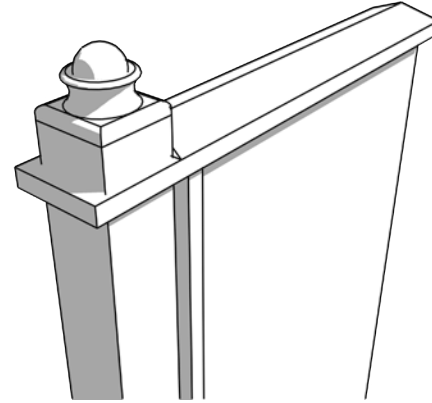

Post, finial, and bracket detail

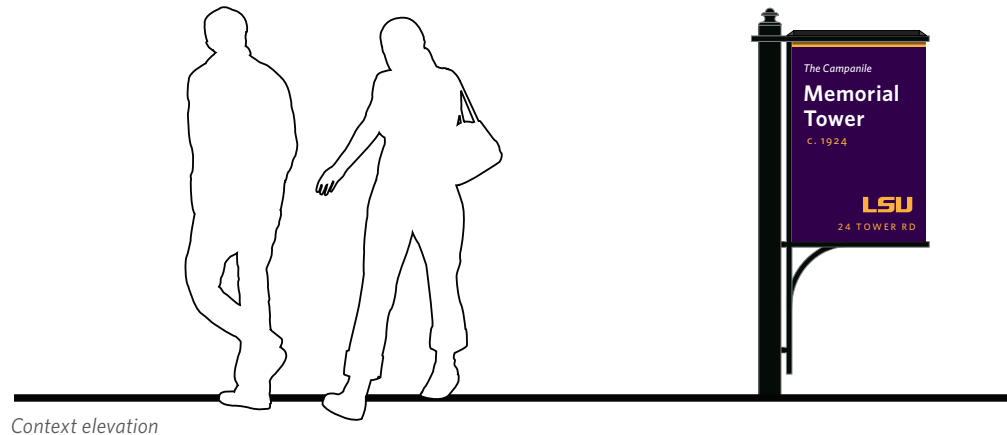

Context elevation



Standard sign face layouts

DESIGN RATIONALE

Secondary facility identification, scaled to be legible and appropriate for pedestrian zones. Sign is non-illuminated, with messages occurring on both faces. Buildings with multiple entrances, and entrances with strictly pedestrian approaches, may use FA2 and FA1 (larger-scaled) signs in combination.

MESSAGE CRITERIA

Identification will be restricted to the official building name, building construction date, street address, and LSU logo. A single department or school generating high levels of visitor traffic may be included, based on written approval from the LSU Office of Finance and Administrative Services (FAS). LSU Law and Ag Center are permitted to use their affiliate logo in a single color (gray) in place of the LSU logo. Use of the affiliate logos shall be restricted to buildings that are either 100% or “mostly” occupied by the respective affiliate. A site plan diagramming LSU Law and Ag Center campus facilities can be found in the Appendix. All FA2 signs shall be reviewed and approved by the LSU Offices of Facility Development and Campus Planning.

PLACEMENT & ORIENTATION

The FA2 sign is intended for use in the core campus, or for other pedestrian-accessed facilities. Signs are to be oriented perpendicular to the building face, unless the orientation obscures legibility from the primary approaches. When a series of buildings face a major walkway or street, signs for each building shall be consistently set back from the pavement edge. Signs should be placed in planting beds to minimize obstruction to mowing and potential damage.



Context elevation

DESIGN RATIONALE

Secondary facility identification, scaled to be legible and appropriate for pedestrian zones. Sign is intended to be used in lieu of Type FA2 when a ground mounted sign is not feasible or deemed inappropriate. Sign is non-illuminated, with messages occurring on one face. Buildings with multiple entrances, and entrances with strictly pedestrian approaches, may use this sign in combination with FA2 or FA1 signs.

MESSAGE CRITERIA

Identification will be restricted to the official building name, building construction date, street address, and LSU logo. A single department or school generating high levels of visitor traffic may be included, based on written approval from the LSU Office of Finance and Administrative Services (FAS). LSU Law and Ag Center are permitted to use their affiliate logo in a single color (gray) in place of the LSU logo. Use of the affiliate logos shall be restricted to buildings that are either 100% or “mostly” occupied by the respective affiliate. A site plan diagramming LSU Law and Ag Center campus facilities can be found in the Appendix. All FA3 signs shall be reviewed and approved by the LSU Offices of Facility Development and Campus Planning.

PLACEMENT & ORIENTATION

Signs shall be oriented to face pedestrian approaches. Placement, especially in regard to historic building facades, will require review by LSU Office of Facility Development and Campus Planning on a case-by-case basis. Sign mounting hardware shall penetrate wall surfaces at mortar joints, minimizing damage to building facades.

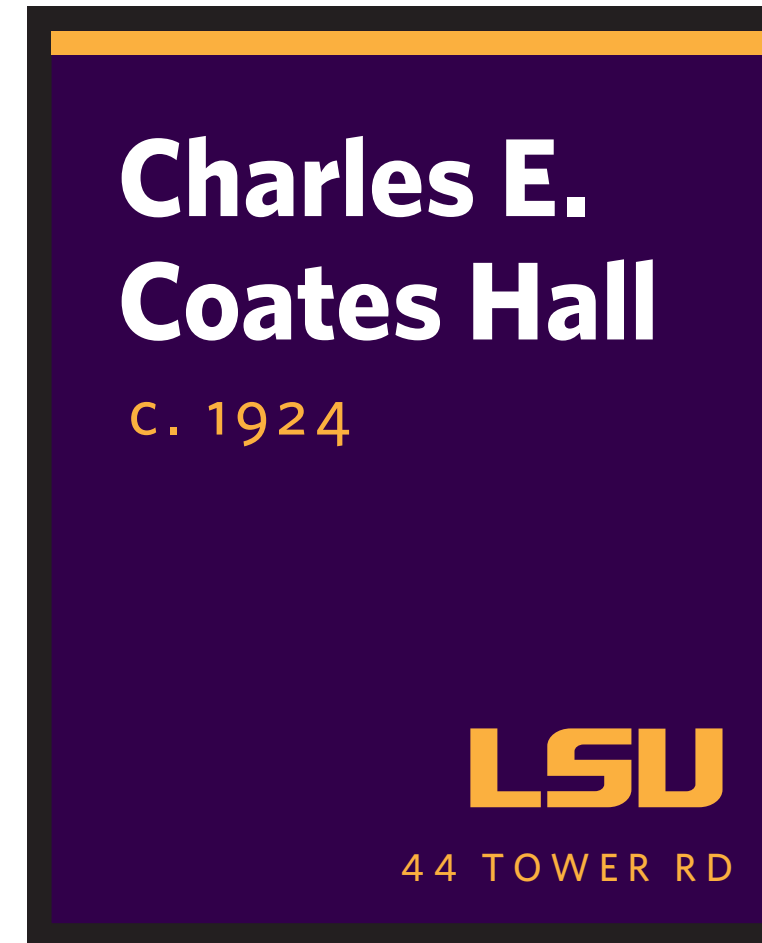

Sign face detail

accessible pathway

FREESTANDING BOLLARD

Low-profile, unobtrusive compliance with ADA accessibility guidelines

Freestanding, when building-mounted is not available or desired

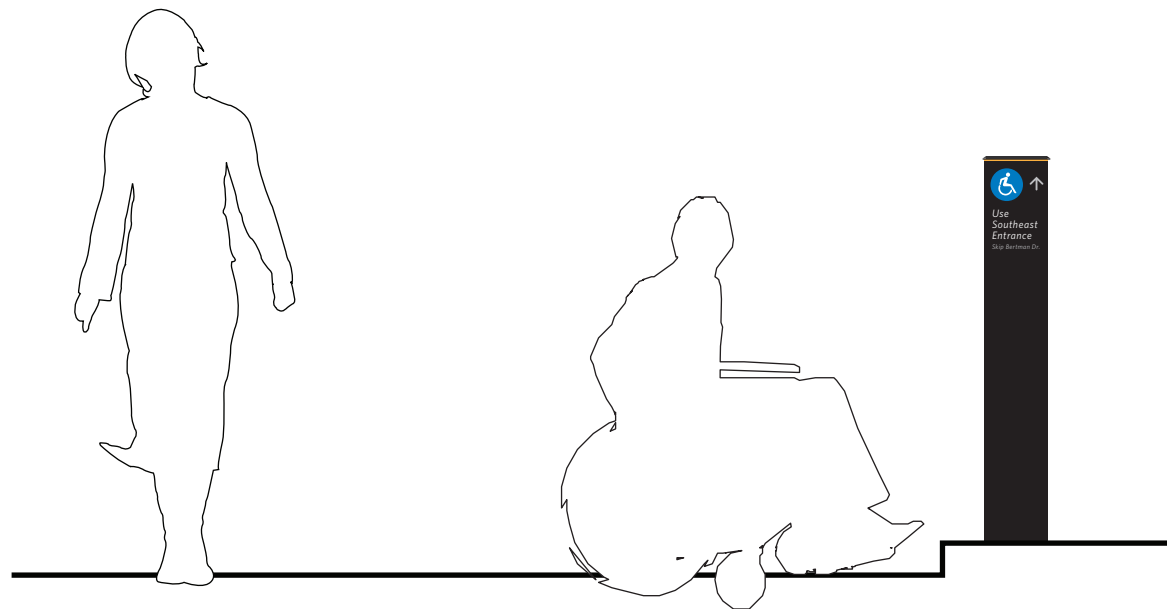

Context elevation



Sign face detail

DESIGN RATIONALE

This sign provides direction to accessible building entrances where the entrance is not immediately visible from the main path of travel, or in instances where an alternate, accessible entrance is provided.

MESSAGE CRITERIA

Signs will display approved building names, international accessibility symbol, and directional messaging.

PLACEMENT & ORIENTATION

Signs will be coordinated with overall campus accessibility program and installed in concert with Type ED Entrance Identity plaques. Signs will be located adjacent to every building entrance or path where a separate accessible entrance is used, and then as required along the path of travel to the accessible entry. Signs shall be set back a minimum 6 inches from the path edge, and their placement must not obstruct any accessible path.

accessible pathway

BUILDING MOUNTED PLAQUE

Low-profile, unobtrusive compliance with ADA accessibility guidelines

Building-mounted option



Context elevation



Sign face detail

DESIGN RATIONALE

This sign provides direction to accessible building entrances where the entrance is not immediately visible from the main path of travel, or in instances where an alternate, accessible entrance is provided.

MESSAGE CRITERIA

Signs will display approved building names, international accessibility symbol, and directional messaging.

PLACEMENT & LOCATION

Signs should be oriented to be visible from pedestrian paths and approaches. Proposed placement, especially in regard to historic building facades, will require review by LSU Office of Facility Development and Campus Planning on a case-by-case basis. Sign mounting hardware should be coordinated to penetrate wall surfaces at mortar joints, minimizing damage to building facades.

Ensures compliance with ADA accessibility guidelines

Reduced sign clutter

Provides consistent facility identification



Context elevation

ED entrance identity

WALL PLAQUE

DESIGN RATIONALE

Sign Type ED will mark all facility entrances in a consistent manner, reinforcing approved building names, and clearly expressing the LSU identity. For accessible entrances, signs will display the accessibility symbol and feature raised text and braille. For non-accessible entrances, the accessibility symbol will be combined with a directional arrow indicating the nearest accessible entry. ED signs can be used in conjunction with AP signs to clearly mark paths to accessible entries. Implementation shall be coordinated with overall campus accessibility program.

MESSAGE CRITERIA

Signs will display approved building names, international accessibility symbol, and directional messaging.

PLACEMENT & ORIENTATION

Sign must be placed next to building entrances, between 48 inches and 60 inches above grade level. Signs should be oriented to be visible from pedestrian paths and approaches. Proposed placement, especially in regard to historic building facades, will require review by LSU Office of Facility Development and Campus Planning on a case-by-case basis. Sign mounting hardware should be coordinated to penetrate wall surfaces at mortar joints, minimizing damage to building facades. Sign locations will be coordinated with the LSU Office of Disability Services.

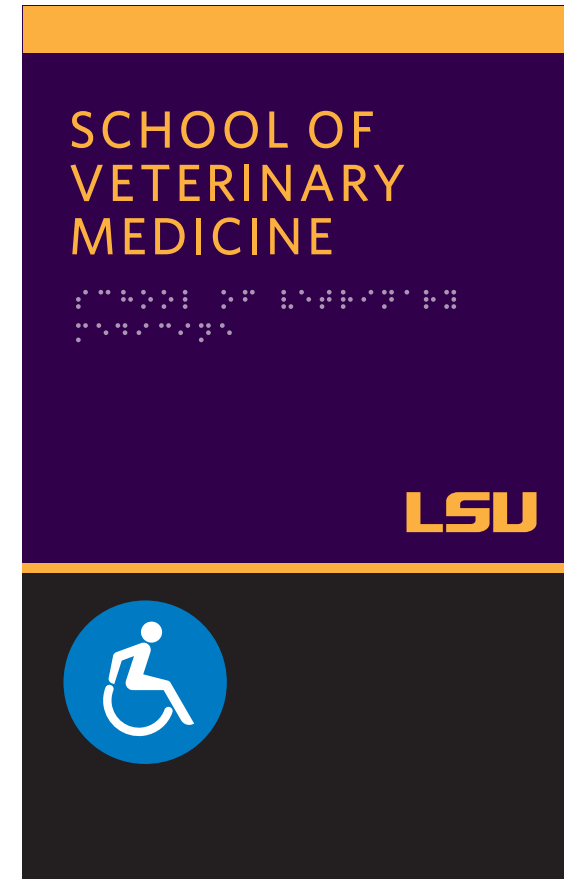

Sign face detail - accessible entrance

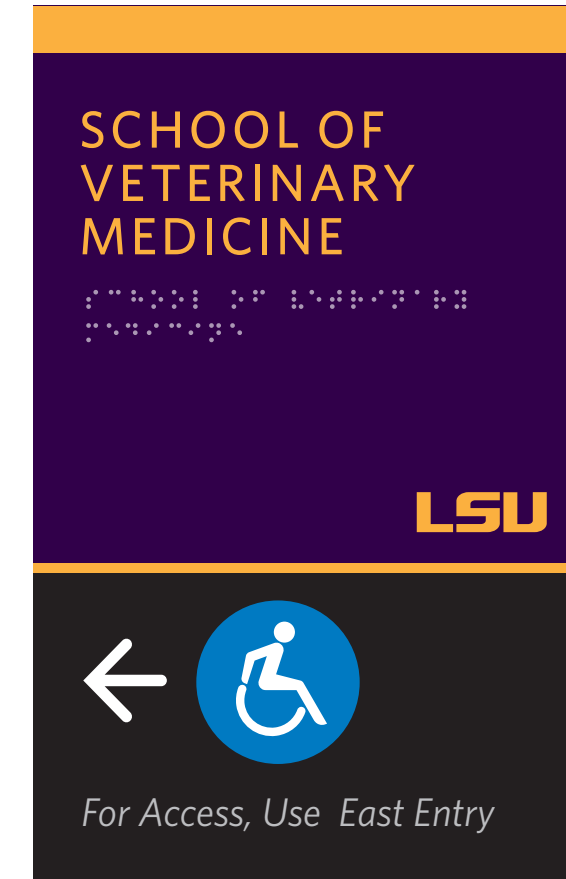

Sign face detail - accessible entry directional

campus kiosk

FOUR-SIDED, PRIMARY

One-stop campus visitor orientation

Detailing complements campus environment

Flexible, with multiple informational configurations

Accommodates future interactive/digital displays

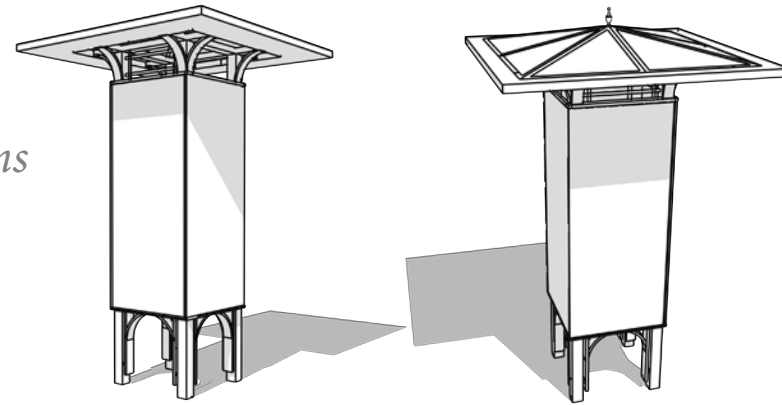

Perspective views



Overall campus map and directory

Area map, 5-minute walk

Two sides of kiosk are available for historic/interpretive display or art panels



Sign face detail

DESIGN RATIONALE

Located at major centers of pedestrian activity, this kiosk consolidates multiple displays of information into a single unit. Future versions may make use of technology-based information systems, including touch-screen wayfinding, ATM machines, parking ticket vending.

MESSAGE CONTENT

“You Are Here”-style maps orient visitors to overall university layout and highlight connections to campus destinations and downtown Baton Rouge. One face is reserved for a large scale campus map with comprehensive index of destinations. A second map, constrained to a five-minute walk radius, provides more localized detail. The other two panels may be used for display of artist works, interpretive/historic information, or campus trail network maps. All proposed content must be reviewed and approved by the LSU Office of Facility Development and Campus Planning; Communications and University Relations; and F.A.S. (Finance / Administration Services.)

PLACEMENT & ORIENTATION

Strategically located near visitor parking areas and pathway junctions. Because of its scale and four-sided configuration, the kiosk should be located in a planned plaza space with ample room—a minimum of 48 inches of clearance on all sides—allocated to circulate around the structure. The placement must not obstruct any accessible path. If the kiosk must be located on a path, a “bump-out” concrete pad must be created, to accommodate the 48 inches of clearance on all sides.

Provides campus orientation from all parking areas

Comprehensive campus map and directory

Low profile design, complementary to campus context

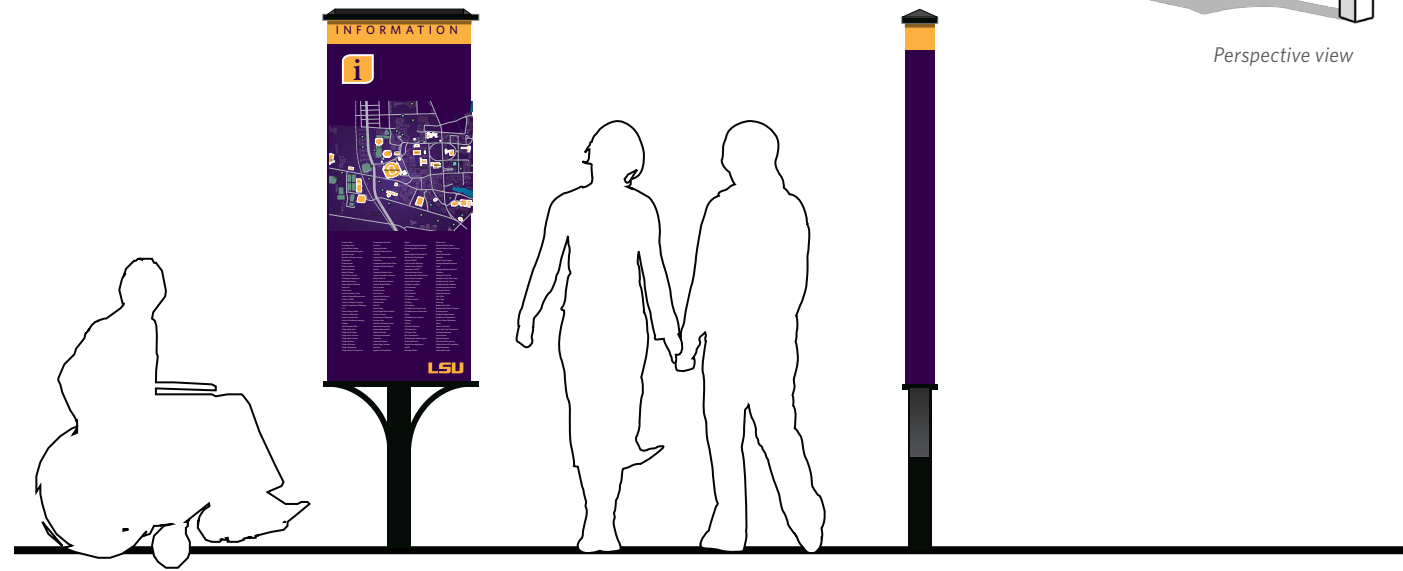

Context elevation

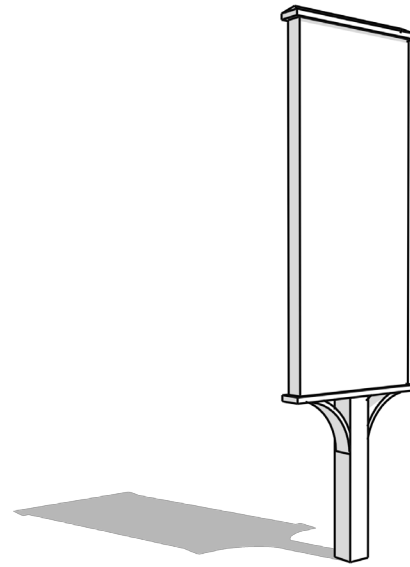

Perspective view

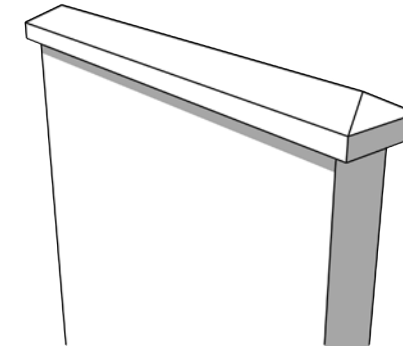

Detail - top cap



Detail—sign face graphics

DESIGN RATIONALE

This smaller kiosk focuses on the overall campus map and directory, and is primarily intended to be used at all campus parking areas. It may also be used throughout the campus to supplement the primary, four-sided kiosks.

MESSAGE CONTENT

Primary content is the large scale campus map with comprehensive index of destinations. As conditions permit, the kiosk may be double sided, with the second face displaying an area map, constrained to a five-minute walk radius, providing localized detail. All proposed content must be reviewed and approved by the LSU Office of Facility Development and Campus Planning and the LSU Office of Communications and University Relations.

PLACEMENT & ORIENTATION

Strategically located in visitor parking area exits. Large parking areas may feature multiple kiosks. Typically located next to pathways, in planting or lawn areas. Depending on conditions, the sign may parallel paths, or be perpendicular, for two-sided configurations.

Brings to life the history and culture of the LSU campus

Reduces sign clutter, consolidates existing variety of sign plaques

Visually tied into the overall wayfinding system

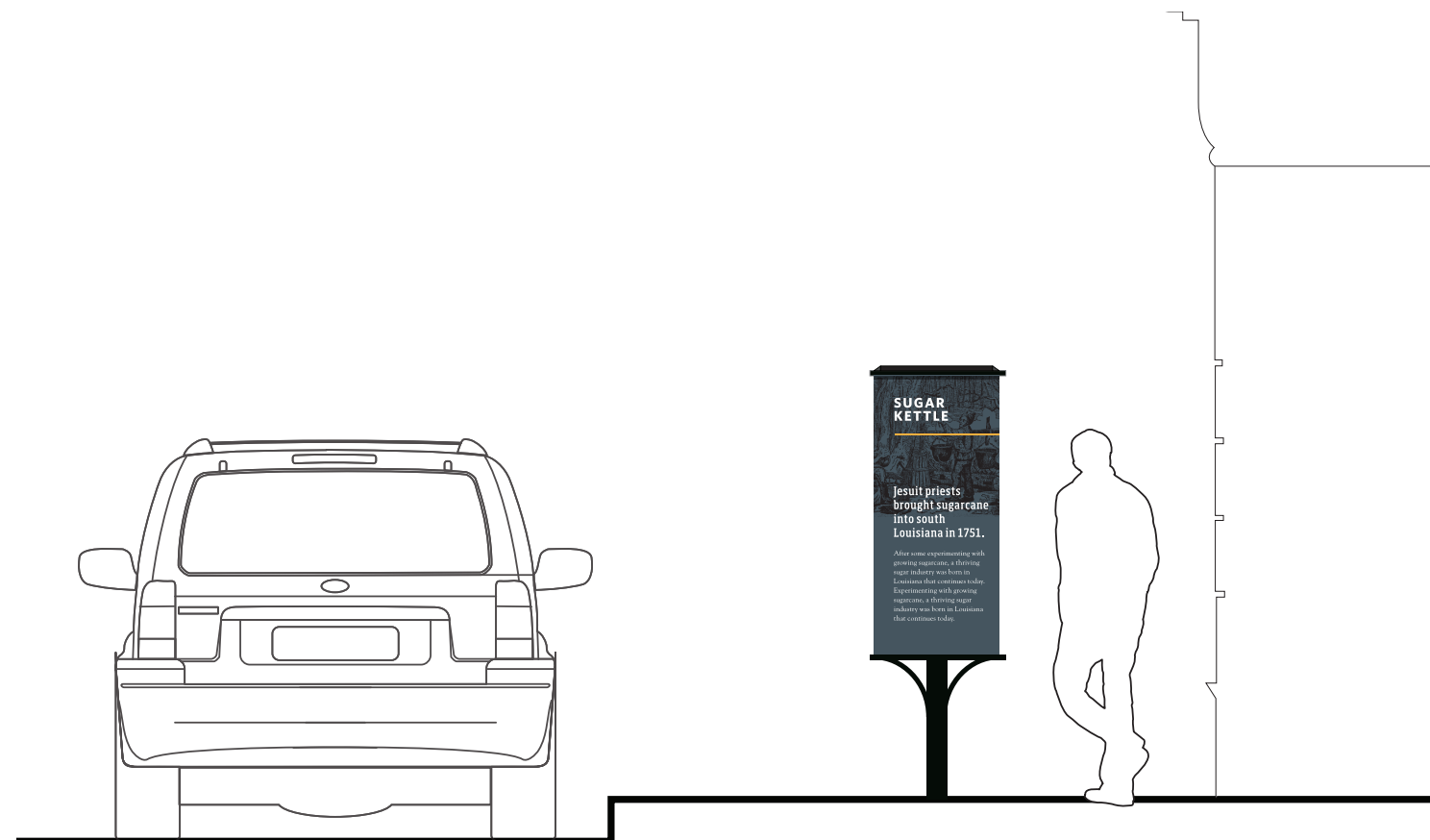

Context elevation

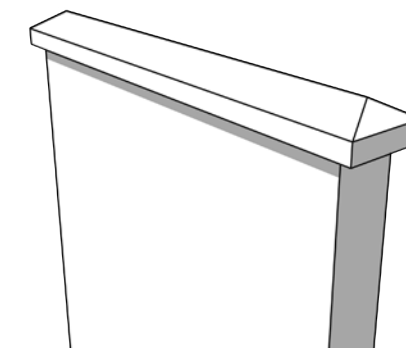

Detail - top cap

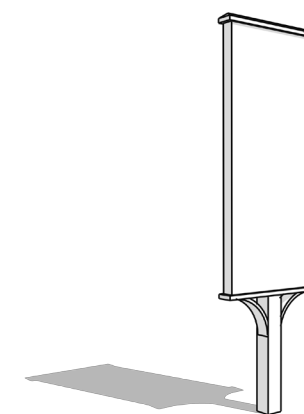

Perspective view

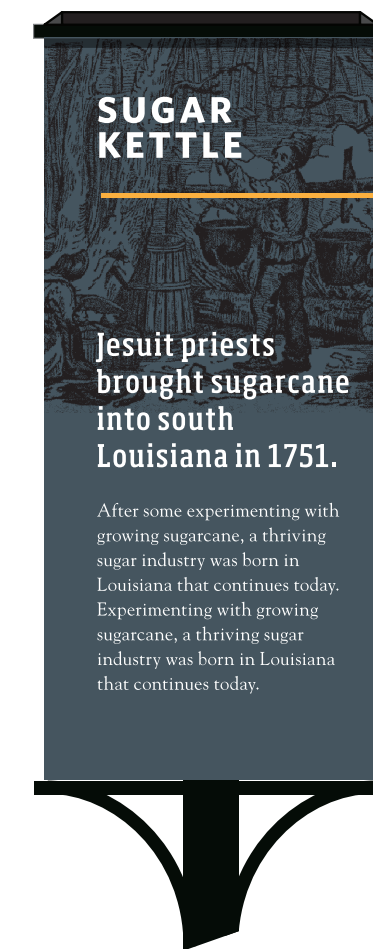

Detail—sign face graphics

DESIGN RATIONALE

The LSU campus contains many areas and sites with cultural and historic significance. Bringing these to light reinforces the sense of place, and illuminates the origins of local traditions. The interpretive sign program consolidates the variety of existing, ad hoc historical plaques and markers into a system of engaging interpretive panels. The system shares components and formats with the overall wayfinding system, yet introduces more variety in color, graphics and imagery.

MESSAGE CONTENT

The designs illustrated in this manual intend to guide overall style, materials, and fabrication techniques. Panel content and imagery will be determined by LSU. Signs may be single or double sided depending on orientation and content needs. Final review and approval of panel designs and locations is by the LSU Office of Facility Development and Campus Planning and the LSU Office of Communications and University Relations.

PLACEMENT & ORIENTATION

Signs are intended to be located near interpretive sites (Indian Mounds, Greek Theatre, etc.) and carefully placed so as to not compromise the site itself. Ideally signs should be located off pedestrian paths, in planting beds, to minimize site disturbance and exposed footings.

Brings to life the history and culture of the LSU campus

Reduces sign clutter, consolidates existing variety of sign plaques

Visually tied into the overall wayfinding system

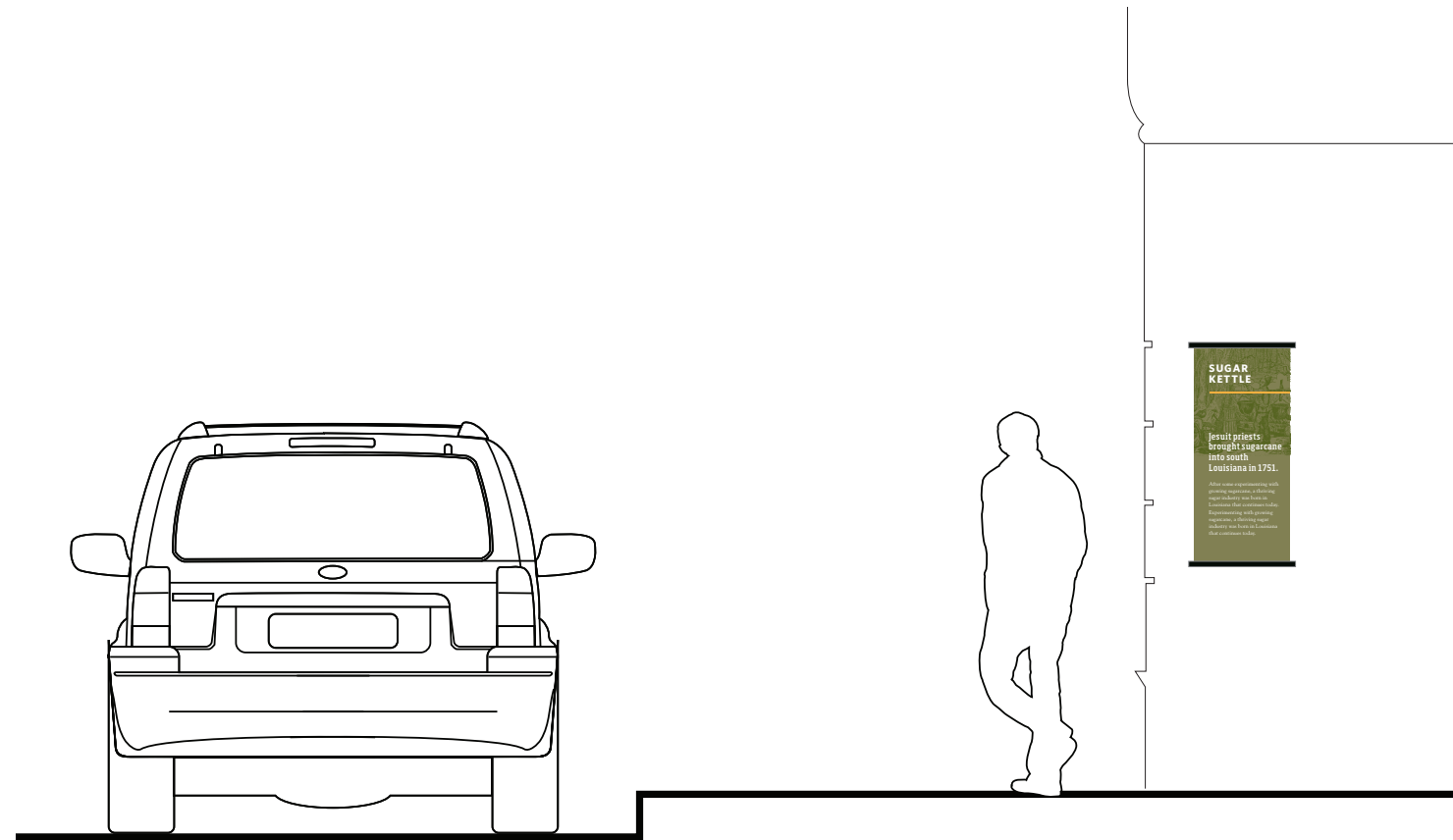

Context elevation



Detail—graphics and imagery style

DESIGN RATIONALE

The LSU campus contains many areas and sites with cultural and historic significance. Bringing these to light reinforces the sense of place, and illuminates the origins of local traditions. The interpretive sign program consolidates the variety of existing, ad hoc historical plaques and markers into a system of engaging interpretive panels. The system shares components and formats with the overall wayfinding system, yet introduces more variety in color, graphics and imagery.

MESSAGE CONTENT

The designs illustrated in this manual intend to guide overall style, materials, and fabrication techniques. Panel content and imagery will be determined by LSU. Final review and approval of panel designs and locations is by the LSU Office of Facility Development and Campus Planning and the LSU Office of Communications and University Relations.

PLACEMENT & ORIENTATION

Signs are intended to be located near interpretive sites, (Allen Hall Murals, etc.) carefully placed so as to not compromise the site itself. Signs should be oriented to be visible from pedestrian paths and approaches. Placement on building facade, will require review by LSU Office of Facility Development and Campus Planning on a case-by-case basis. Sign mounting hardware should be coordinated to penetrate wall surfaces at mortar joints, minimizing damage and need for extensive patching should the sign require removal.

Coordinates identity for all campus trails

Reinforces LSU identity

Raises awareness of fitness options

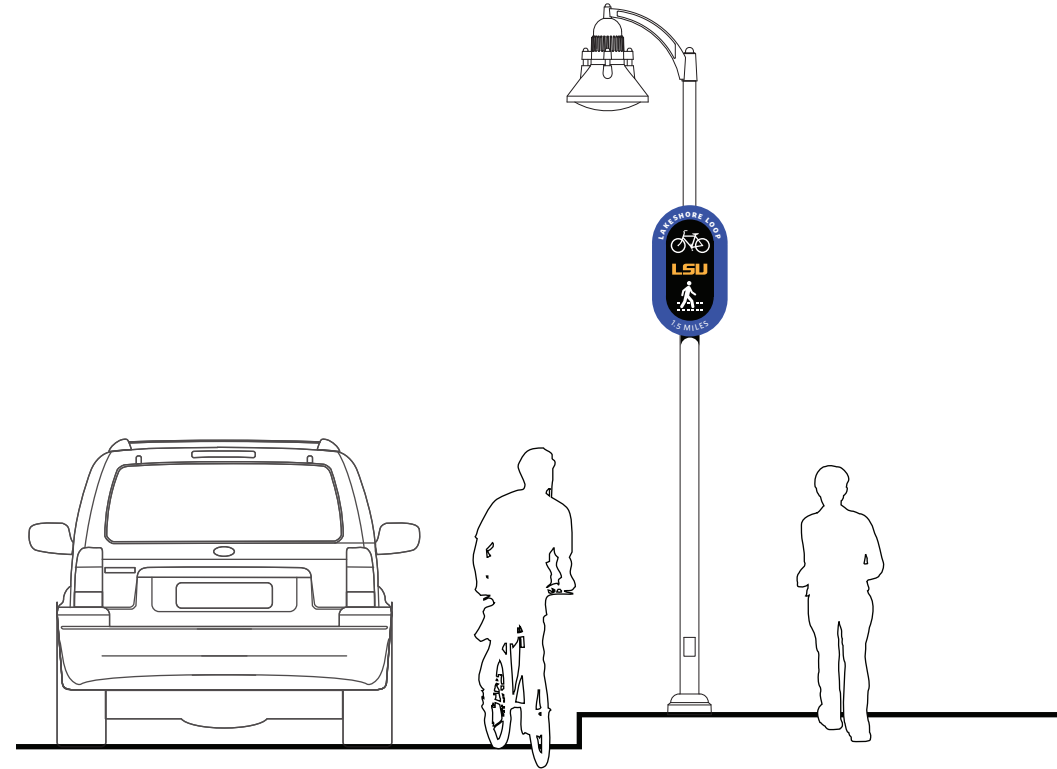

Context Elevation



Sign Face Detail

DESIGN RATIONALE

As part of the initiative to promote healthy lifestyles and encourage non-vehicular connections, trails will be marked and identified to raise awareness of the LSU campus trails system, and their availability for walking, biking and running.

MESSAGE CRITERIA

Signs will display approved trail names, symbology and milepost data.

PLACEMENT & ORIENTATION

Located at key trail crossroads, or intersections of bike trails with streets. Generally mounted to existing light poles, located adjacent to dedicated mixed use path. The placement must not obstruct pathway.

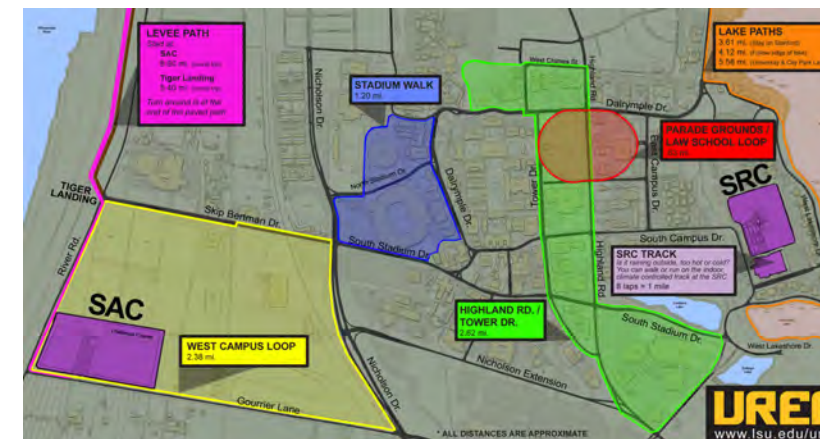

LSU Campus Trail System courtesy of UREC

campus shuttle

BUS STOP SIGN WITH ROUTES

Increase visibility of the Tiger Trails system

Provide comprehensive route list at each stop

Design integration with overall campus wayfinding



Context elevation

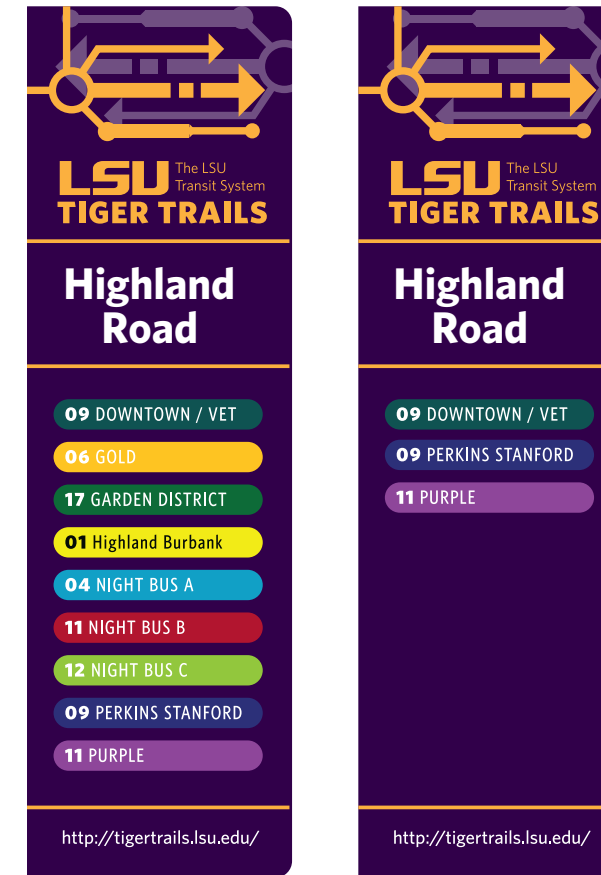

Detail: sign face graphics

DESIGN RATIONALE

Located at campus shuttle bus stops, where the posting of schedule information is desired.

MESSAGE CRITERIA

Signs will display Tiger Trails logo and graphics, street (stop) name, route list, and website address. Route strips are digitally printed vinyl allowing for ease of updating. Final messaging to be coordinated by LSU office of parking, Traffic, and Transportation

PLACEMENT & ORIENTATION

Locate the shuttle stop sign adjacent to a sidewalk, set back 6 inches from the edge with blade facing away from the street. The placement must not obstruct any accessible path. If no sidewalk is present, locate at least 2 feet minimum back from front of curb, with blade facing away from the street. **Locations off-campus require coordination with the City and LADOT.**

Uniform system of event traffic control

Adaptable for emergency management in addition to University events

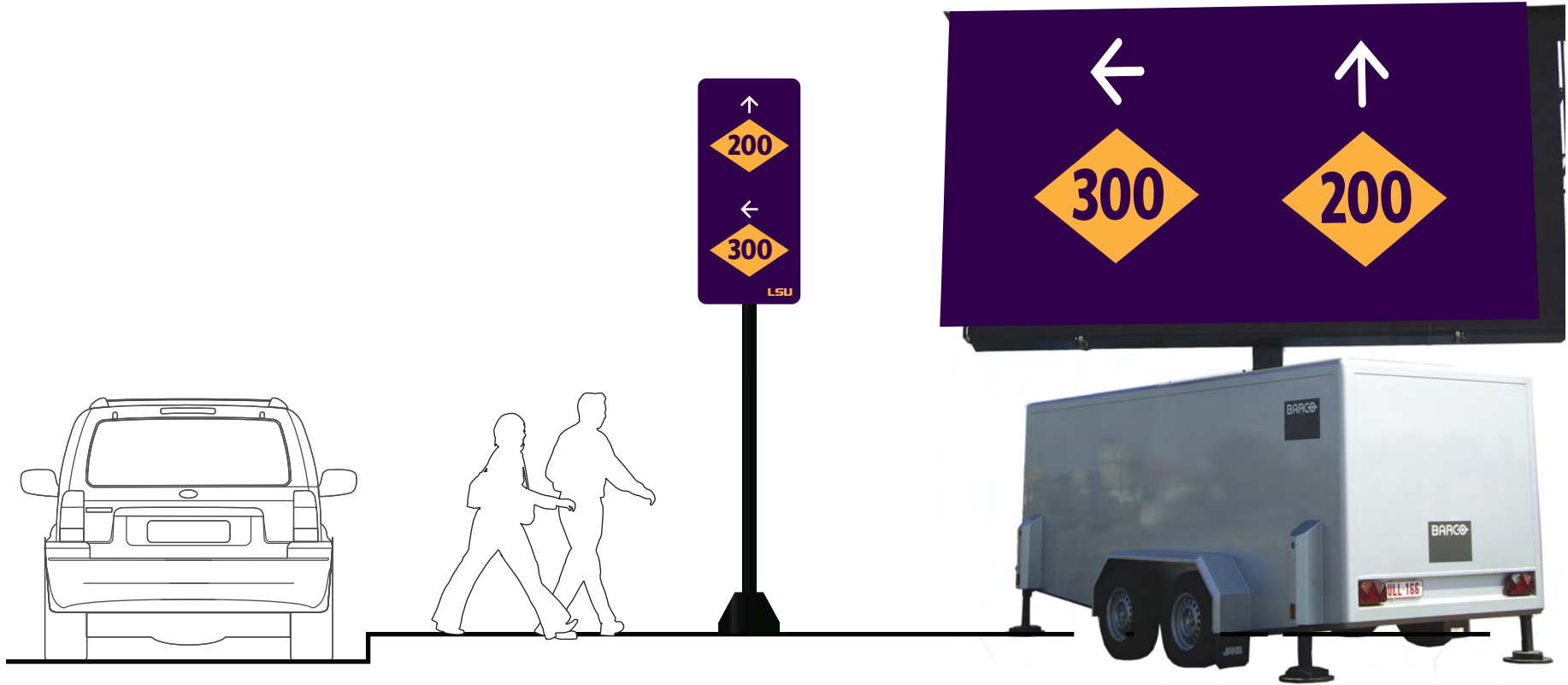

Context elevations: zone directionals

Context elevations: portable electronic message board

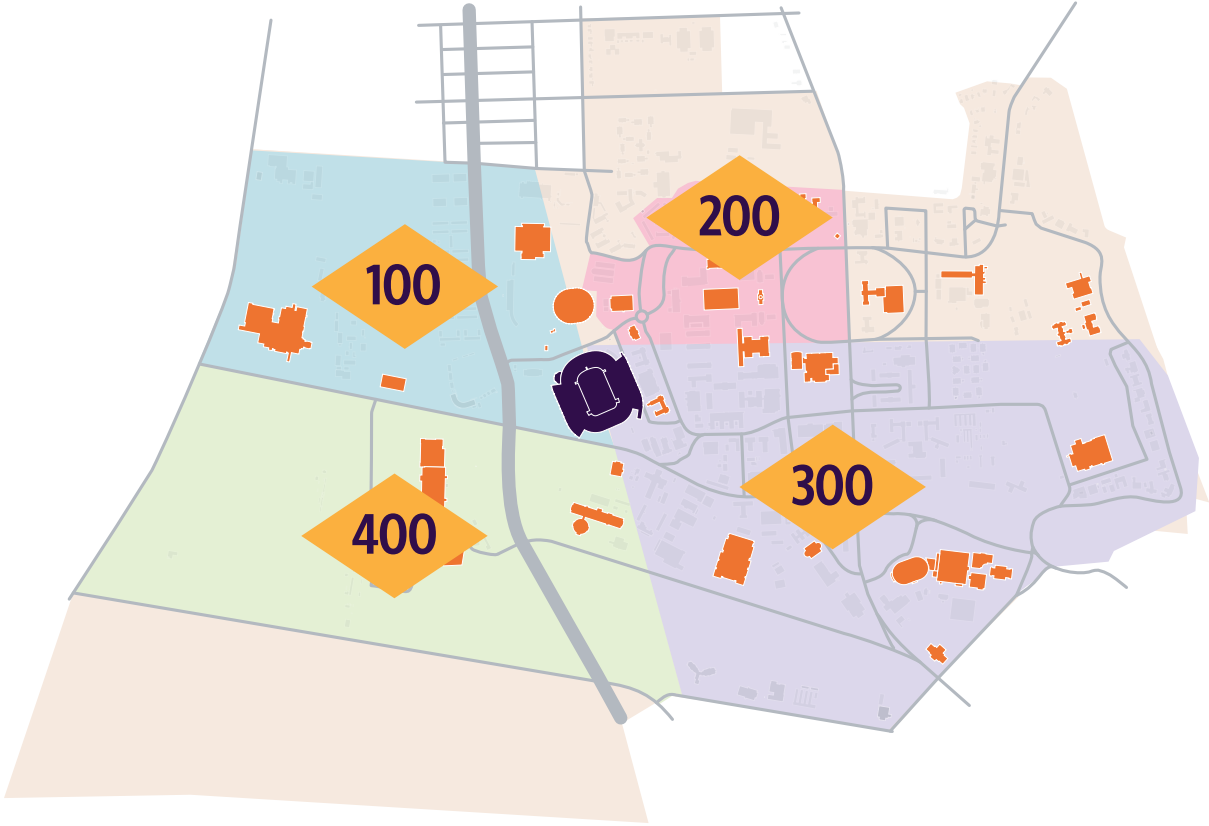

Event parking zones

DESIGN RATIONALE

A new system of coordinated temporary signage will replace the current ad-hoc method of directing traffic for game-day and other large events. Safety and clear wayfinding is emphasized, along with the desire to reinforce the LSU brand during these high-visibility events.

MESSAGE CRITERIA

Portable digital displays will provide flexible communication solutions, and can deliver critical messages as required for emergency management plans. Messages will be developed by the LSU Office of Parking, Traffic, and Transportation in coordination with the LSU Athletic Department.

PLACEMENT & ORIENTATION

The strategy for game-day parking divides up the parking areas into four zones, simplifying wayfinding and direction-giving.

event signage

PARKING ZONE IDENTIFICATION

Better image for LSU, reinforces brand

Simplified parking zones, reduce visitor confusion



Context elevations: lot identity, freestanding



Detail: sign face graphics

DESIGN RATIONALE
 Based on the event parking zone strategy, bold and consistent signage will identify parking lots and zones within larger lots. Freestanding A-frame style signage and temporary post and panels respond to the various site conditions, presenting a professional, uncluttered image.

MESSAGE CRITERIA
 Signs will display temporary lot names, parking zones, and parking restrictions. Optional text may display dates of event. Messages will be developed by the LSU Office of Parking, Traffic, and Transportation and the LSU Athletic Department.

PLACEMENT & ORIENTATION
 Sign panels may be mounted to "A-frame" portable structures, or temporary posts with concrete base

Uniform display of event parking regulations

Attractive and functional moveable barricades with message panels

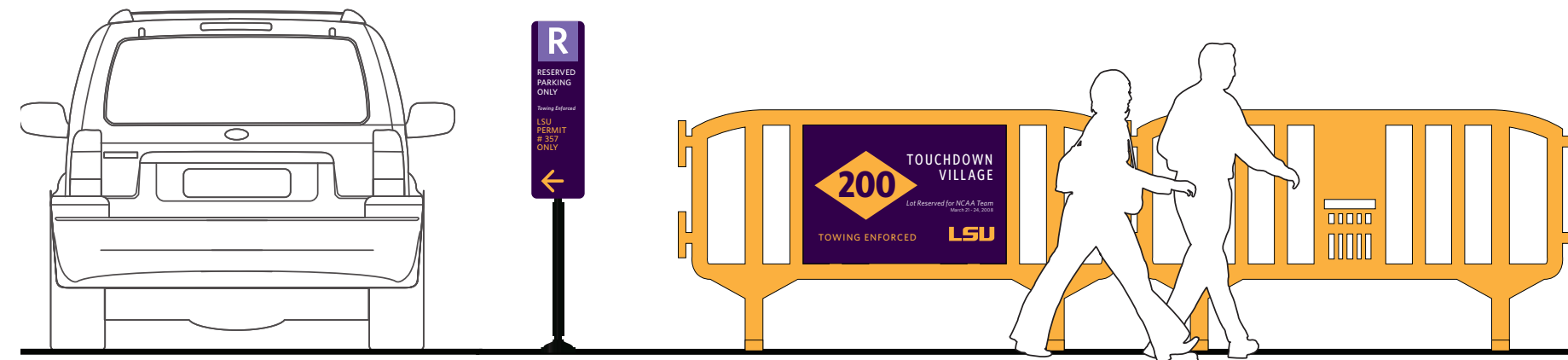

Context elevation: post and panel, integrated barrier



Detail: sign face graphics



Example: low profile magnetic base

DESIGN RATIONALE

A series of pre-lettered sign panels will be stocked by Campus Parking for use on event days to address temporary regulatory and parking restrictions. These sign panels will be integrated into moveable barricades or utilize a ground attachment method that allows secure mounting, yet easy removal and a minimum of installed hardware at the ground plane.

MESSAGE CRITERIA

Signs will display event lot names, parking zones, and parking restrictions. Optional text may display dates of event. Messages will be developed by the LSU Office of Parking, Traffic, and Transportation.

PLACEMENT & ORIENTATION

Sign posts may feature magnetic flush base design, allowing for secure mounting with ease of removability, ie: "Gorilla Posts."

Moveable barricades are designed to accommodate a sign panel for regulatory information as required.



3 SPECIFICATIONS

A strategy of design standards, applied throughout the sign program, helps to maintain consistency of look and feel as well as presentation of information. Standards have been developed for the following design elements:

UNIVERSITY IDENTITY

TYPOGRAPHY

SIGN COLORS AND MATERIALS

SYMBOLS AND ARROWS

STANDARD DETAILS

INDIVIDUAL SIGN DETAILS

LSU

Primary logo

LSU

LOUISIANA STATE UNIVERSITY

LOUISIANA STATE UNIVERSITY

Logotype



OVERVIEW

The primary logo and wordmark should appear on signs only as specifically designated in this Manual. Use of the primary logo and logomark in the campus wayfinding program follows guidelines outlined in the LSU Visual Identity Program (March 2007) as published by the LSU Office of Communications and University Relations.

The logo should not be altered or enhanced by the use of shadows or outlines. The logo should not be horizontally or vertically altered, i.e., stretched or condensed. The Memorial Tower graphic and the University seal is not utilized in the signage program.

To reproduce the logo or logotype, official electronic files provided by the LSU Office of Communications and University Relations shall be obtained

Highland Rd
Central Campus

T1 Whitney Bold

T2 Whitney Medium

Memorial Tower

T3 Whitney Book Italic

Welcome

T6 Whitney Book

NO PARKING

TOWING ENFORCED

T4 Whitney Black / T5 Medium Small Caps

TOUCHDOWN VILLAGE

T7 Whitney Condensed Medium

200

T8 Whitney Condensed Bold

OVERVIEW

The standard typeface for the sign program is Whitney. Initially developed for New York's Whitney Museum, this font has numerous advantages:

- Works in crowded environments
- Legible at a distance
- Sturdy enough to withstand a variety of fabrication techniques
- Compact forms and broad x-height use space efficiently, and its ample counters and open shapes make it clear under any circumstances
- Carefully designed to resist distortion or material weakness, producing letterforms that are stable over a wide range of sizes and applications

Specific styles are used for various applications and are called out for each sign type. Characters from each style are shown here for visual reference.

Whitney is available in PC and Macintosh formats from:

Hoefler & Frere-Jones, Inc.
 611 Broadway, Room 725
 New York, NY 10012-2608
 Tel. 212 777 6640
 Fax 212 777 6684
 info@typography.com

Clear, versatile, thoughtful

Wide range of weights and styles

SIGN COLORS AND MATERIALS

COLOR AND MATERIAL SOURCES

Paints are Matthews Acrylic Polyurethane, available from LakeView Corporate Park
8201 100th Street
Pleasant Prairie, WI 53158-2201
1-800-323-6593 www.matthewspaint.com

Vinyls are 3M, available from
3M Center, Building 0220-12-E-04
St. Paul, MN 55144 USA
1-800-328-3908 www.3M.com/graphics

Avery Graphics, available from
Graphics and Reflective Products Division
Plainsville, OH 44077 USA
1-800-443-9380 www.averygraphics.com

Arlon Calon Series, available from
Arlon
2811 South Harbor Blvd.,
Santa Ana, CA 92704
800-854-0361 www.arlon.com

COLOR APPLICATION GUIDELINES

Authority for color determination rests with the LSU Office of Facility Development and Campus Planning.

Official LSU brand colors



PMS 268

PMS 123

Paints



AP1 Purple
Akzo Nobel 488H5
Satin Finish

AP2 Gold
Matthews Acrylic
Polyurethane to match
PMS 143

AP3 Black
Matthews Acrylic
Polyurethane 30132

AP4 White
Matthews Acrylic
Polyurethane

Powdercoatings



PC1 Sahara Gold Metallic
Tiger Drylac 49/90137

PC2 Rust FT FMT
Tiger Drylac 49/62711

PC3 Black Semi Gloss
Tiger Drylac 39/80040

Pantone Colors (Interpretive Signs)



PMS 7497

PMS 5753

PMS 432

Vinyls



V1 Reflective Yellow
3M Scotchlite 680-71

V2 Reflective White
3M Scotchlite 680-10

V3 Chrome Yellow
Calon 165 EF

V4 Graphite
Calon 80 EF

V5 Olympic Blue
3M 7725-57



V6 Reflective Light Blue
3M 680-76



V7 Reflective Red
680-72



V8 White
3M 7725-10



V9 Purple Reflective
Avery HV1200-565-R

SYMBOLS AND ARROWS

SYMBOL SOURCES

Symbols used in the system are custom designed for LSU Campus Wayfinding Signage Guidelines, or are accepted standards established by:

Federal Highway Administration
Society for Environmental Graphic Design
American Institute of Graphic Arts

SYMBOL APPLICATION GUIDELINES

Use of symbols not provided in these Guidelines must be reviewed by the LSU Office of Facility Development and Campus Planning.

Parking Zones



Regulatory



Arrows



Icons



Gameday Parking



SIGN BASES

post and sleeve

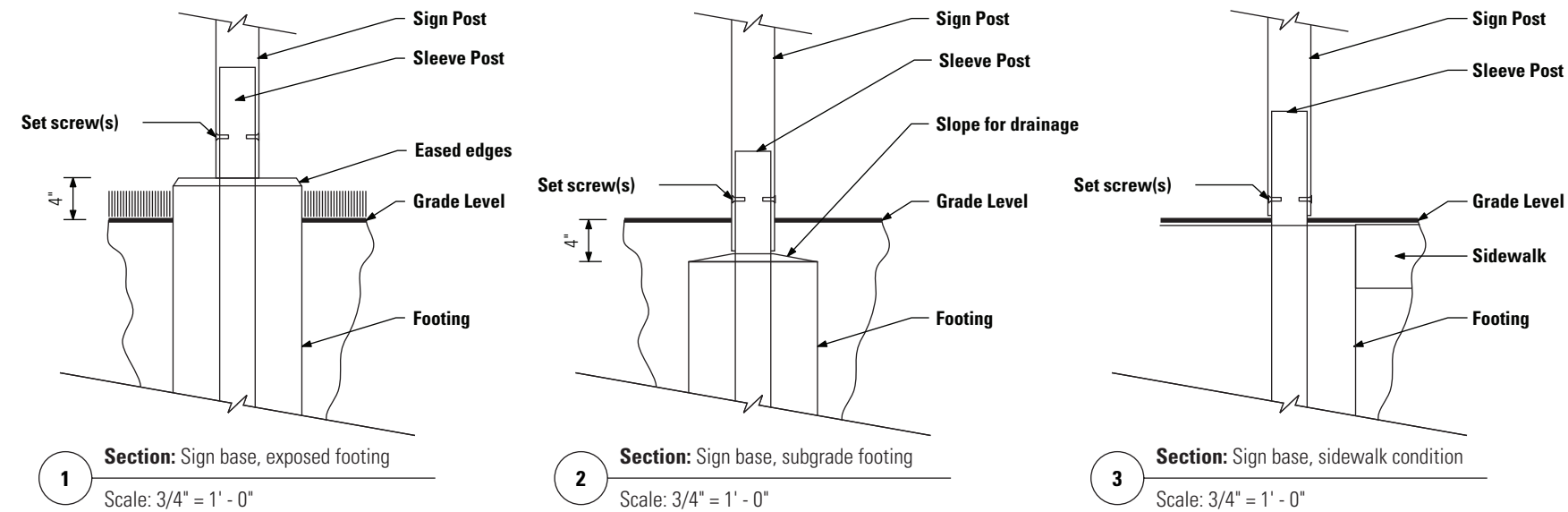

SIGN BASES

break-away

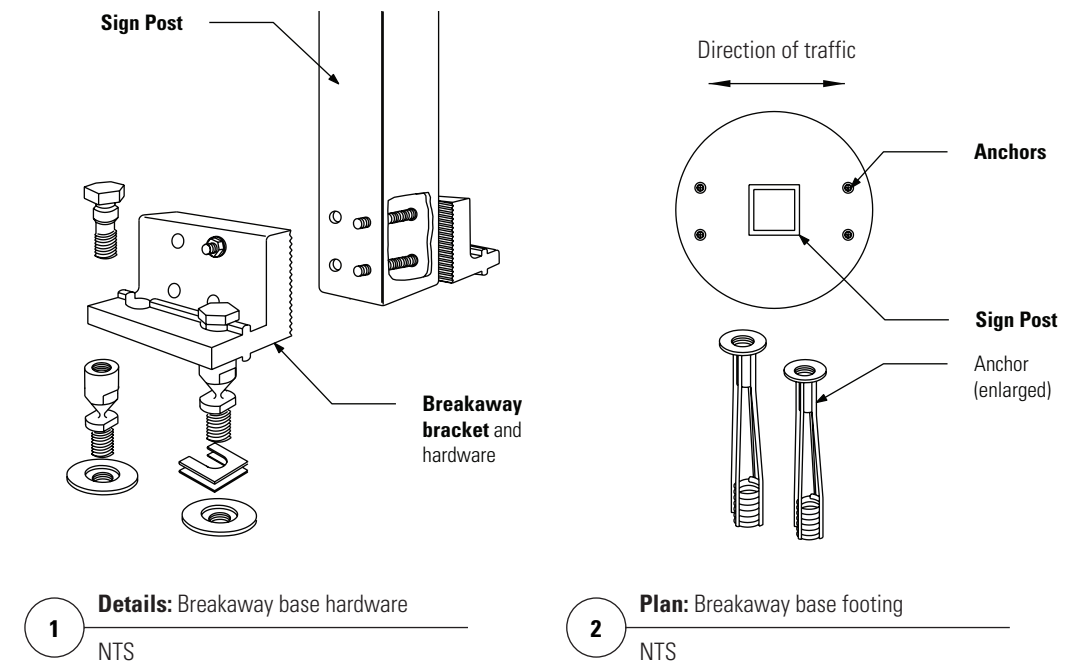

REFERENCE INFORMATION

The need for breakaway footings for signs located near roadways will be determined during installation phases. The details illustrated here are shown as a recommended approach, and will require final approval by LADOT and the City.

Breakaway details courtesy of;
Transpo Industries Inc.
20 Jones Street
New Rochelle, NY 10801

SIGN BASES

cast concrete,
fabricated cabinet

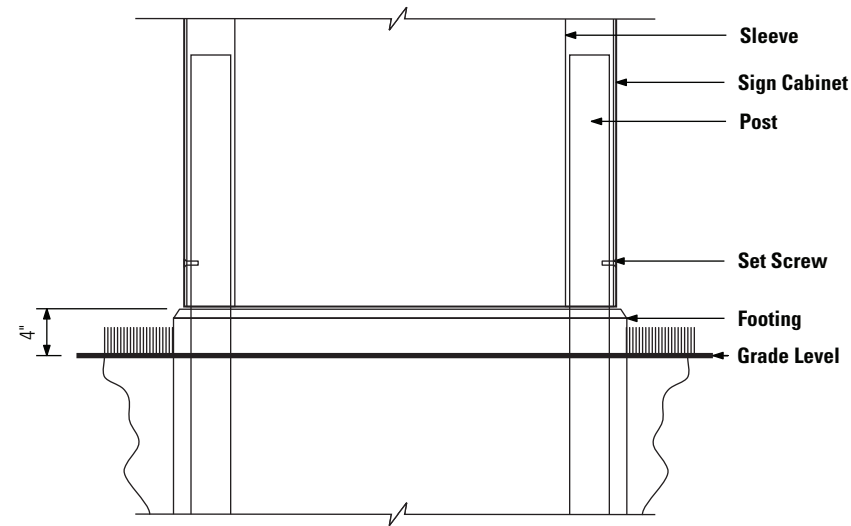

1 Section: Base detail, fab. cabinet signs
Scale: 3/4" = 1' - 0" Type PK.2

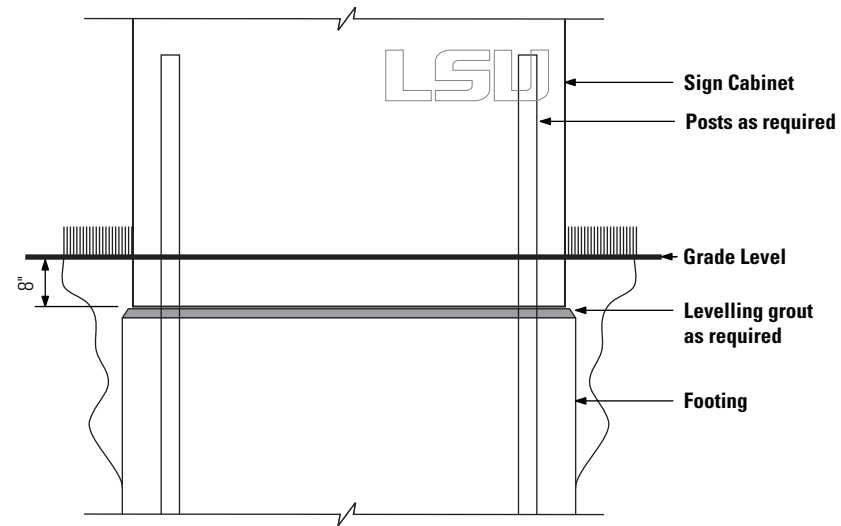

2 Section: Precast sign base and footing
(Not to scale) Type DR.1

TYPICAL DETAILS

removable sign face

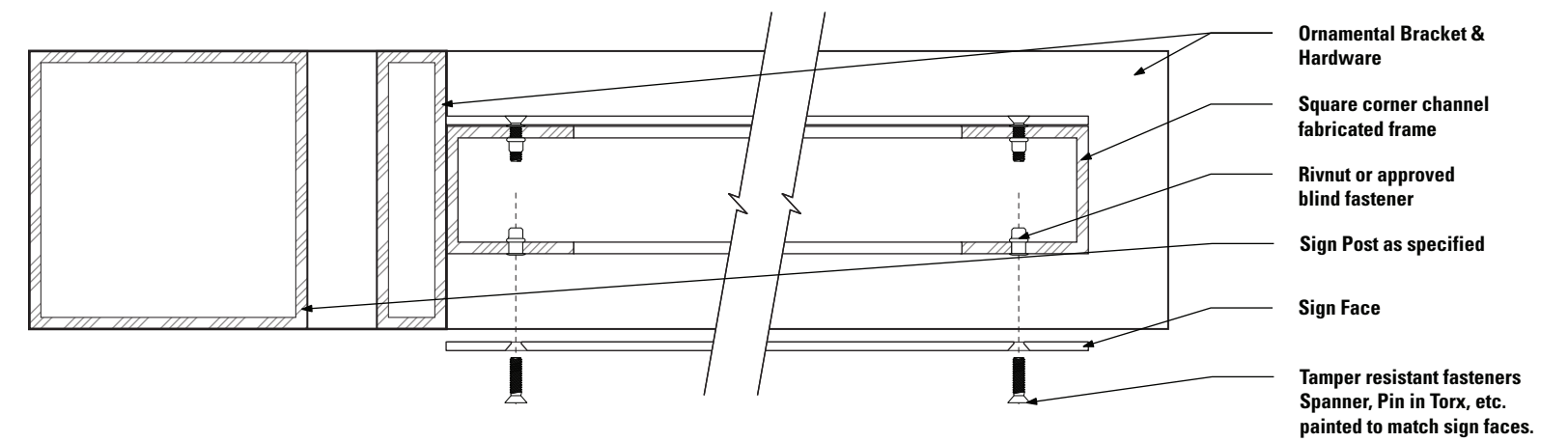

- Ornamental Bracket & Hardware
- Square corner channel fabricated frame
- Rivnut or approved blind fastener
- Sign Post as specified
- Sign Face
- Tamper resistant fasteners
Spanner, Pin in Torx, etc.
painted to match sign faces.

TYPICAL DETAILS

finials

DESIGN INTENT

These custom designs are inspired by detailing on the historic gateways, and lend elegance and texture to the sign types in the LSU Wayfinding system. Finials can be fabricated, turned from aluminum, or cast from resin. It is recommended that a certain amount of attic stock of the various sizes be fabricated and kept on hand. Finials are to be securely attached to, and painted to match, sign posts and kiosks.

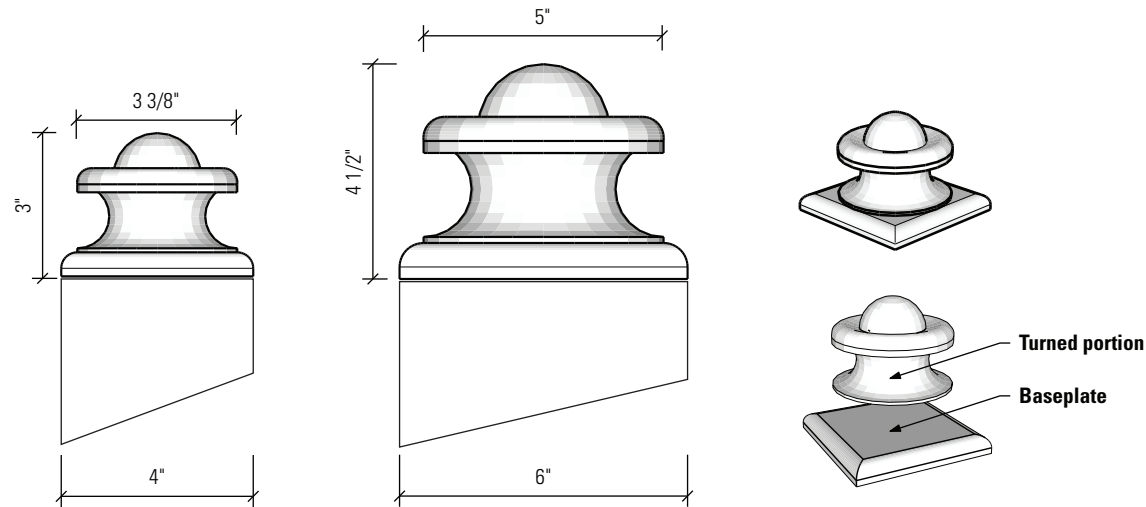

1 Detail: Sign Post Finial, 4" and 6" posts
3" = 1'-0"

2 Detail: Sign Post Finial, components
Not to scale

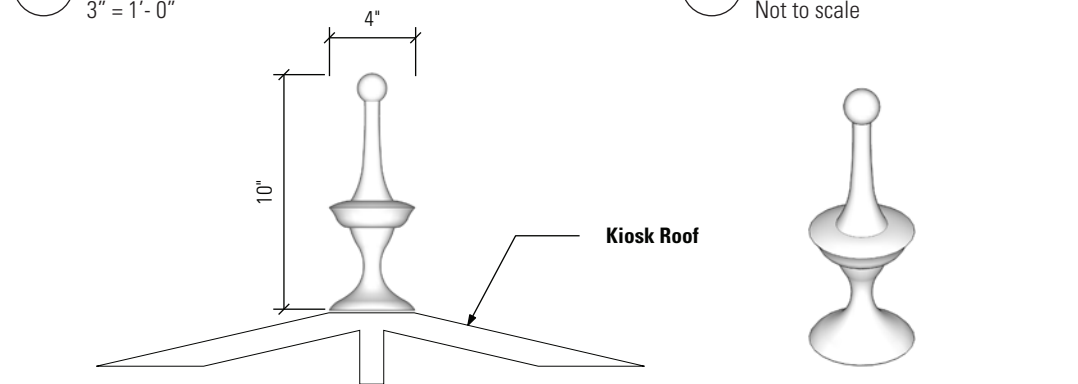

3 Detail: Kiosk Finial
1 1/2" = 1'-0"

4 Detail: Kiosk Finial, isometric view
Not to scale

SIGN PLACEMENT

pedestrian paths and accessibility

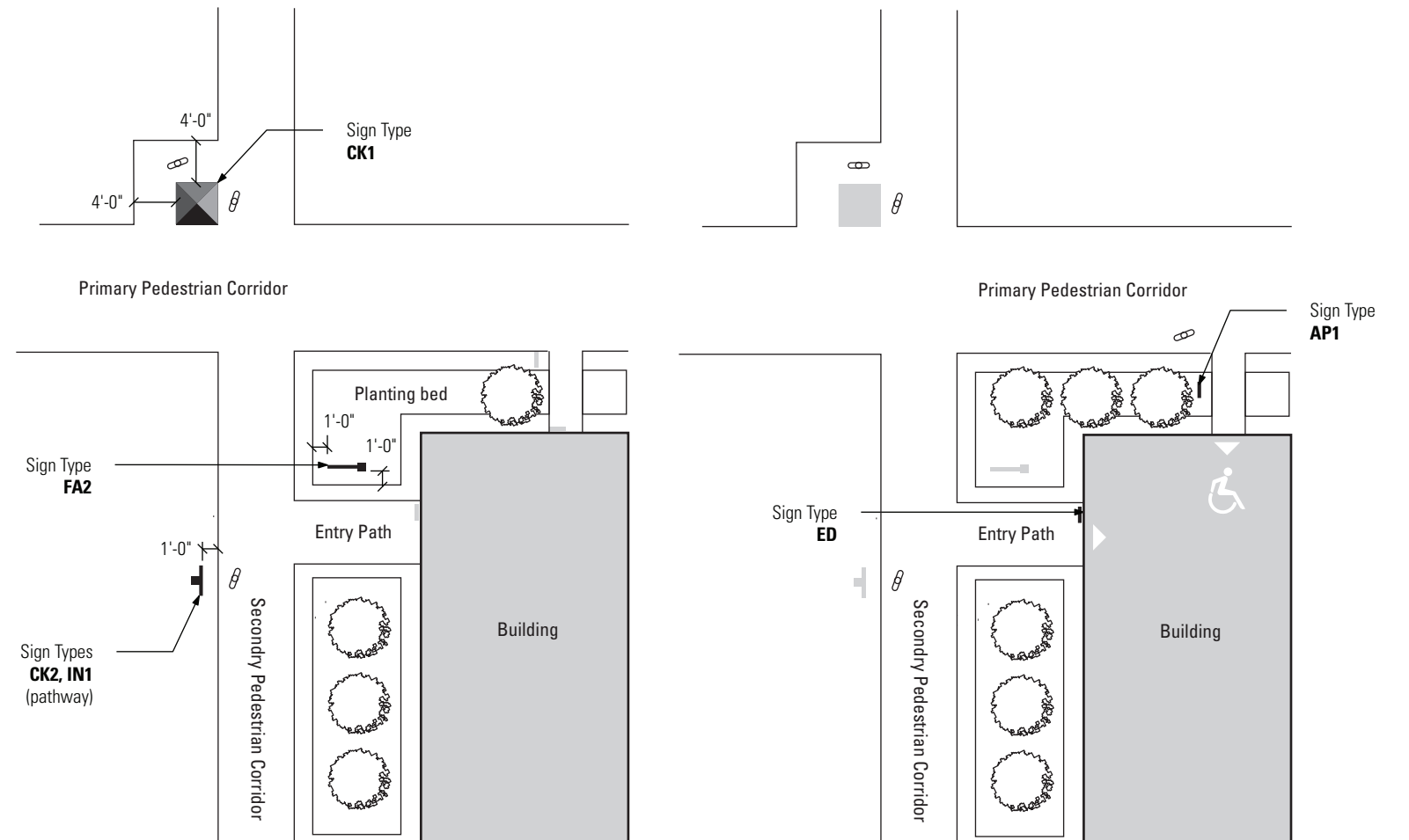

SIGN PLACEMENT

parking and directional

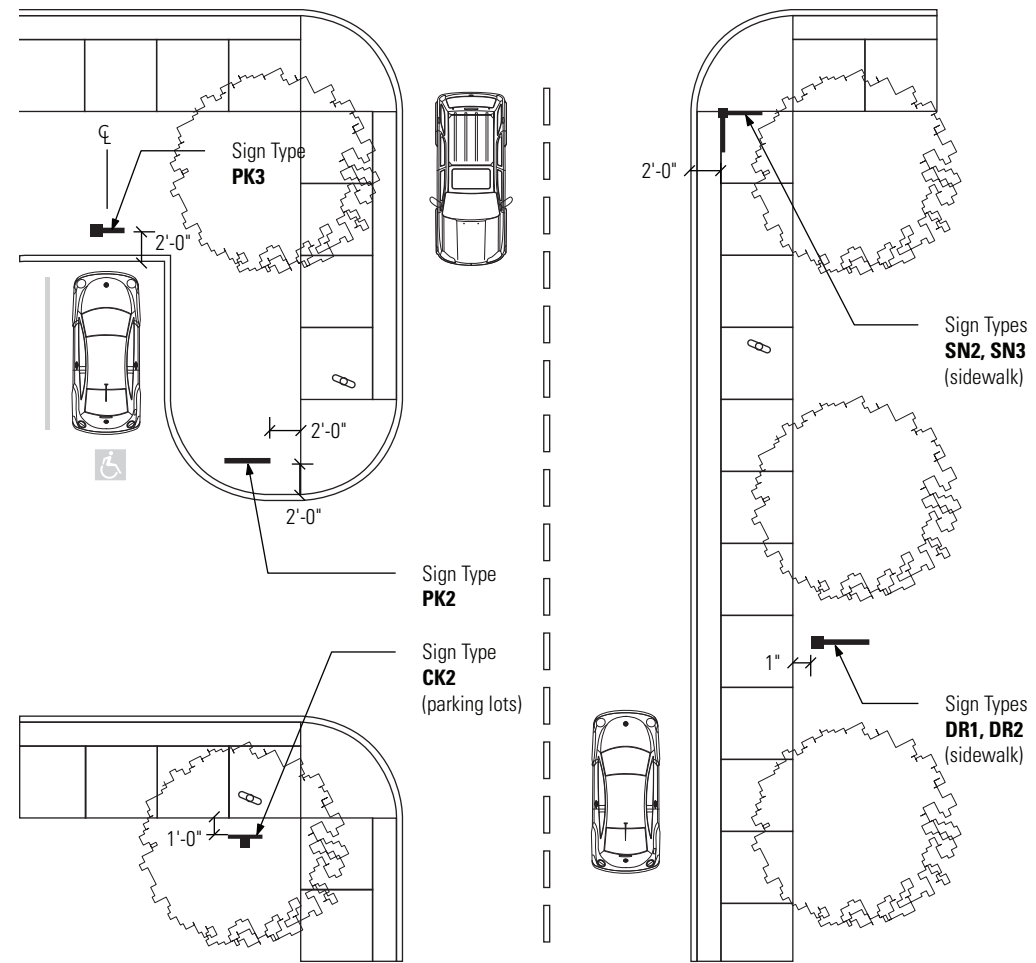

SIGN PLACEMENT

facility identity

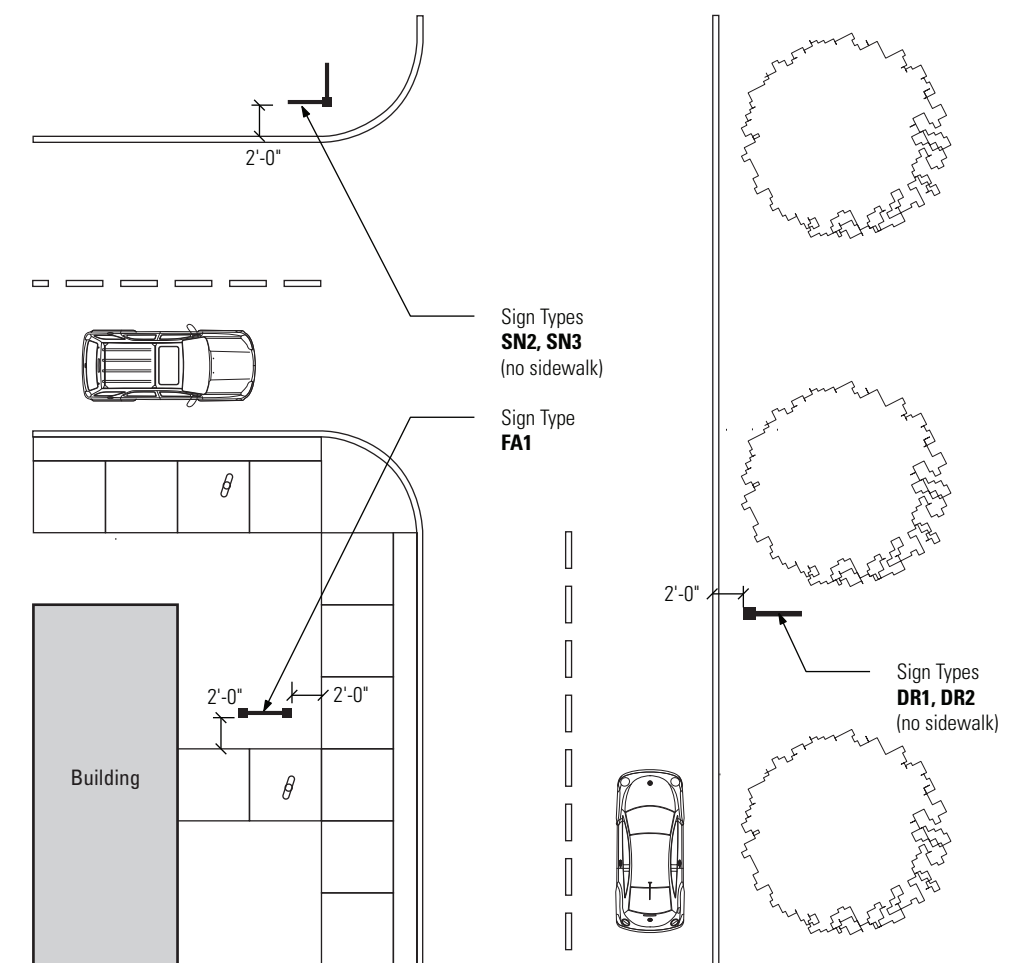

3.1 SIGN DETAILS

AP1 Accessible pathway - bollard	116	RG1 Regulatory – parking – freestanding	147
AP2 Accessible pathway - wall	117	RG2 Regulatory – parking – polemount	148
BC Banner – corridor	118	RG3 Regulatory – traffic	149
BP Banner – perimeter	119	RT Regional trail	150
CG1 Campus, gateway - historic	120	SN1 Street name – 10” legend	151
CG2 Campus, gateway – Darymple/W. Lakeshore	122	SN2 Street name – 6” legend	152
CG3 Campus, gateway – Nicholson	124	SN3 Street name – 4” legend	153
CG4 LSU Icon	126	TB Trailblazer	154
CK1 Kiosk – large	128		
CK2 Kiosk – small	129		
CS1 Campus – shuttle	130		
DR1 Vehicular Directional – off campus	131		
DR2 Vehicular Directional – on campus	132		
ED Entry identity	133		
EV1 Event – parking	134		
EV2 Event - traffic	135		
EV3 Event - detail	136		
FA1 Facility ID – large freestanding	137		
FA2 Facility ID – small freestanding	138		
FA3 Facility ID – building mounted	139		
GE1 Gated entry	140		
GE2 Gated entry	141		
IN1 Interpretive – freestanding	142		
IN2 Interpretive – building mounted	143		
PK1 Parking – structured	144		
PK2 Parking – lot	145		
PK3 Parking – on street	146		

AP1

accessible pathway

BOLLARD SIGN

FABRICATION DETAILS

- Top Cap: Fabricated aluminum “pyramidal” shape, AP3
- Accent: 1/2” h., V3
- Accessibility Symbol: 4” h., circle, V5; symbol, V8
- Arrow: 1 3/4” sq., V8
- Sign Panel: aluminum rectangular tube. AP3
- Entry Designation: 7/8” h., T3, V8
- Secondary Message: .5” h., T3, V4
- Sign Base: above grade (lawn) or below grade (planting bed)

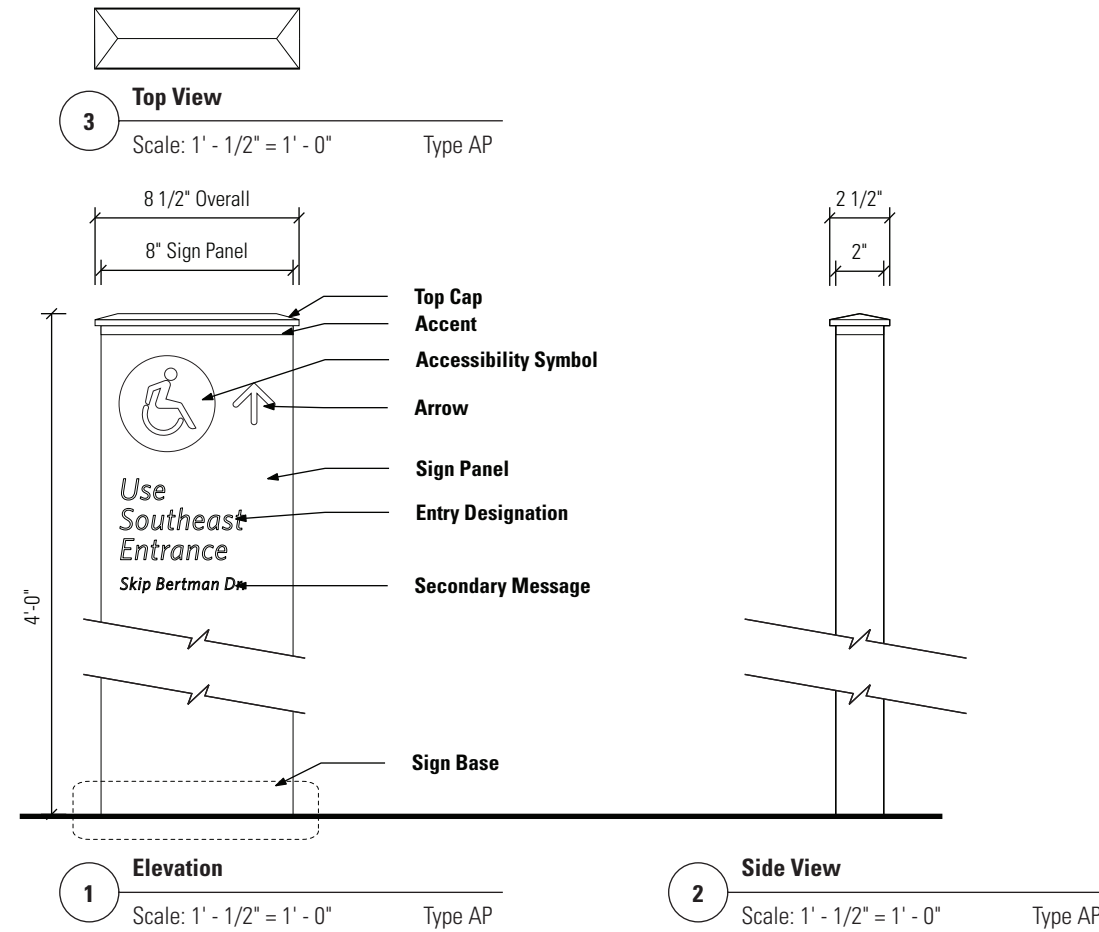

AP2

accessible pathway

WALL MOUNTED SIGN

FABRICATION DETAILS

- Accent: 1/5” h., V3
- Accessibility Symbol: 4” h., circle, V5; symbol, V8
- Arrow: 1 3/4” sq., V8
- Entry Designation: 7/8” h., T3, V8
- Sign Panel: 1/4” thick aluminum panel mounted with blind studs in existing wall, AP3
- Entry Designation: 7/8” h., T3, V8
- Secondary Message: .5” h., T3, V4

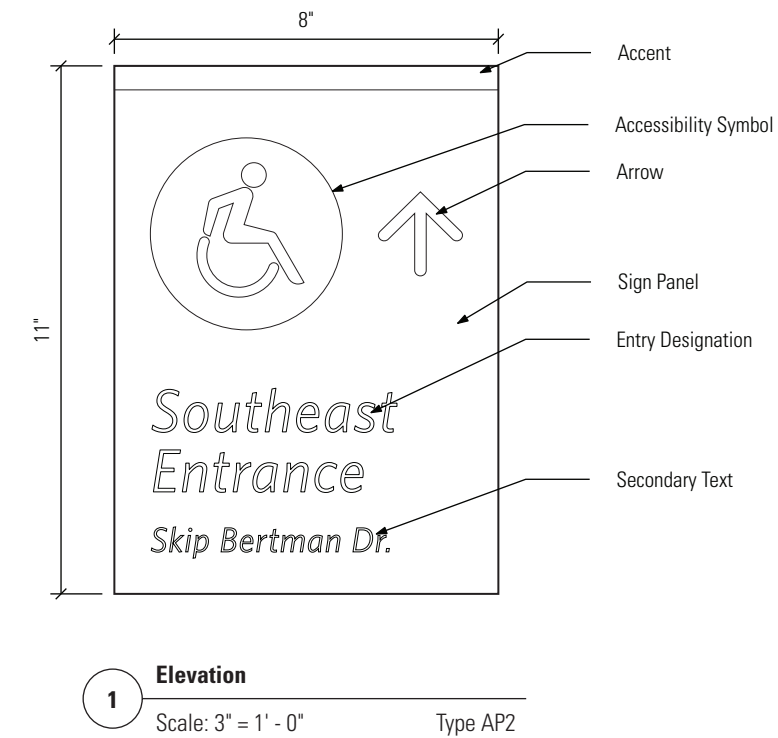

BC

banner

CORRIDOR

FABRICATION DETAILS

- Small/Large Banner: Sunbrella cloth or approved equal to match, Pantone 268
- Logotype: 1 3/8" h., slikscreened copy to match, Pantone 2587
- Logo: 4" h., Sunbrella cloth or approved equal to match, Pantone 123
- Accent: 1 1/5" h., Sunbrella cloth or approved equal to match Pantone 123
- Bracket: KBW BannerFlex or equal, PC3

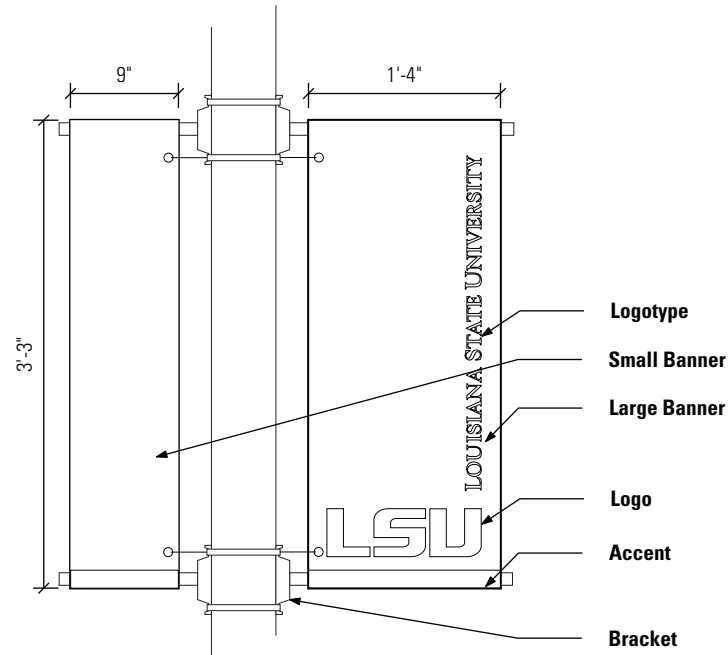

1 Detail
Scale: 3/4" = 1' - 0" Type BC

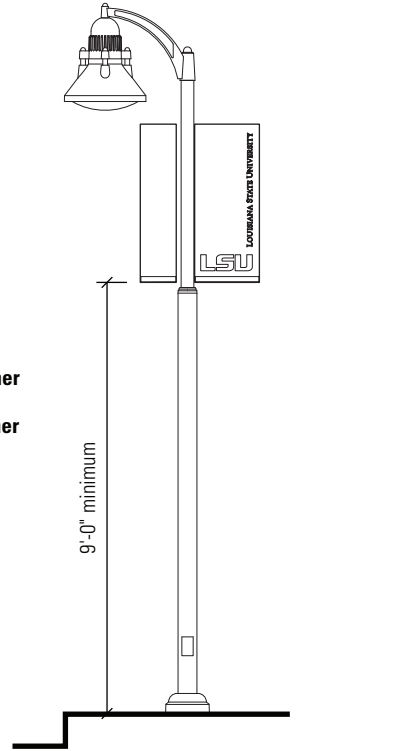

2 Elevation
Scale: 1/4" = 1' - 0" Type BC

BD

banner

PERIMETER

FABRICATION DETAILS

- Small/Large Banner: Sunbrella cloth or approved equal to match, Pantone 268
- Logotype: 3 3/8" h., Sunbrella cloth or approved equal to match, Pantone 123
- Logo: 5 3/4" h., Sunbrella cloth or approved equal to match, Pantone 123
- Accent: 2" h., Sunbrella cloth or approved equal to match Pantone 123
- Bracket: KBW BannerFlex or equal, PC3

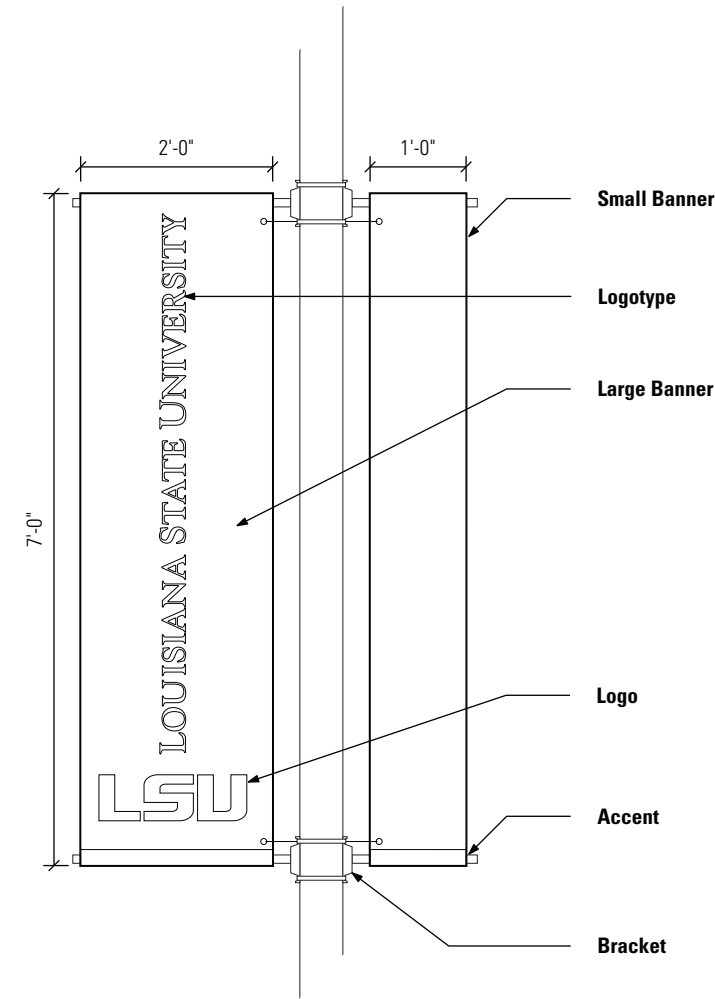

1 Detail
Scale: 1/2" = 1' - 0" Type BP

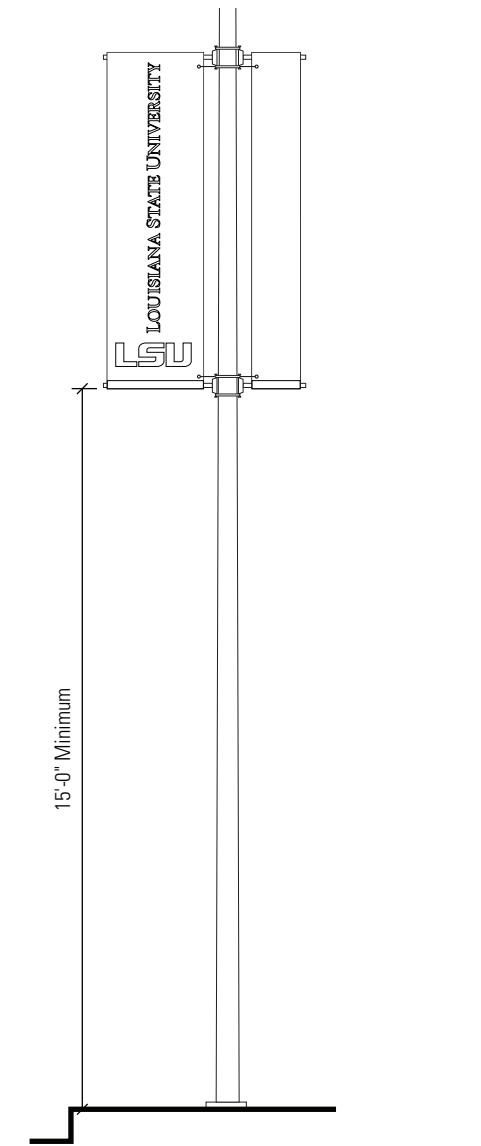

2 Elevation
Scale: 1/4" = 1' - 0" Type BP

CG1

campus gateway

HISTORIC

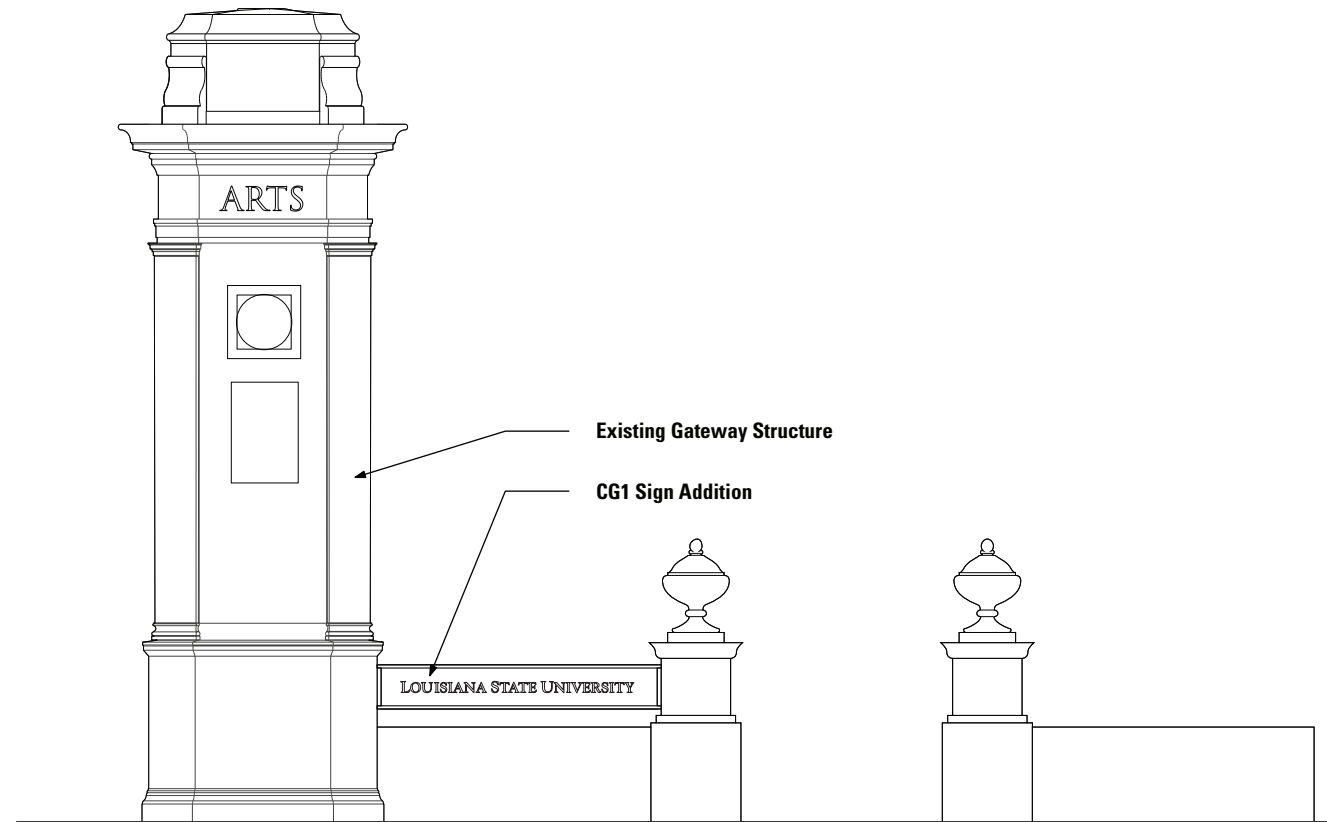

1 Elevation
 Scale: 1/4" = 1' - 0"
 Type CG1

CG1

campus gateway

HISTORIC

FABRICATION DETAILS

- Frame: 3/4 inches x 1.5 inches rectangular aluminum tube PC3
- Sign Panel: 1/4 inches thick aluminum panel PC2
- Logotype: 2 3/4 inches high 1/4 inches thick dimensional letters PC1
- Lighting: Illuminate entire Gateway with concealed, ground-mounted, LED uplights

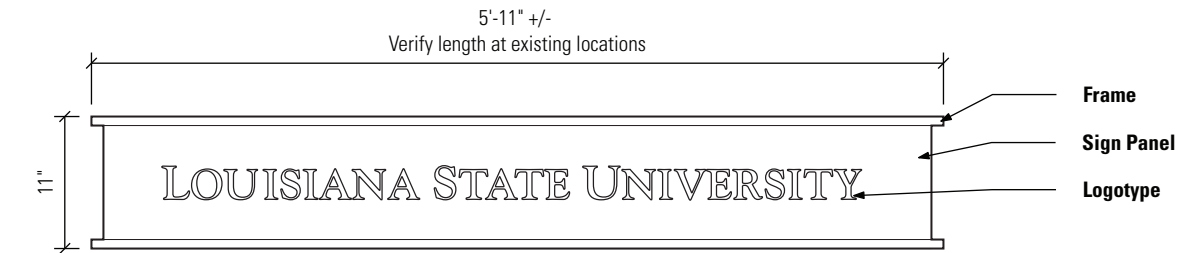

A Sign Detail
 Scale: 3/4" = 1' - 0"
 Type CG1

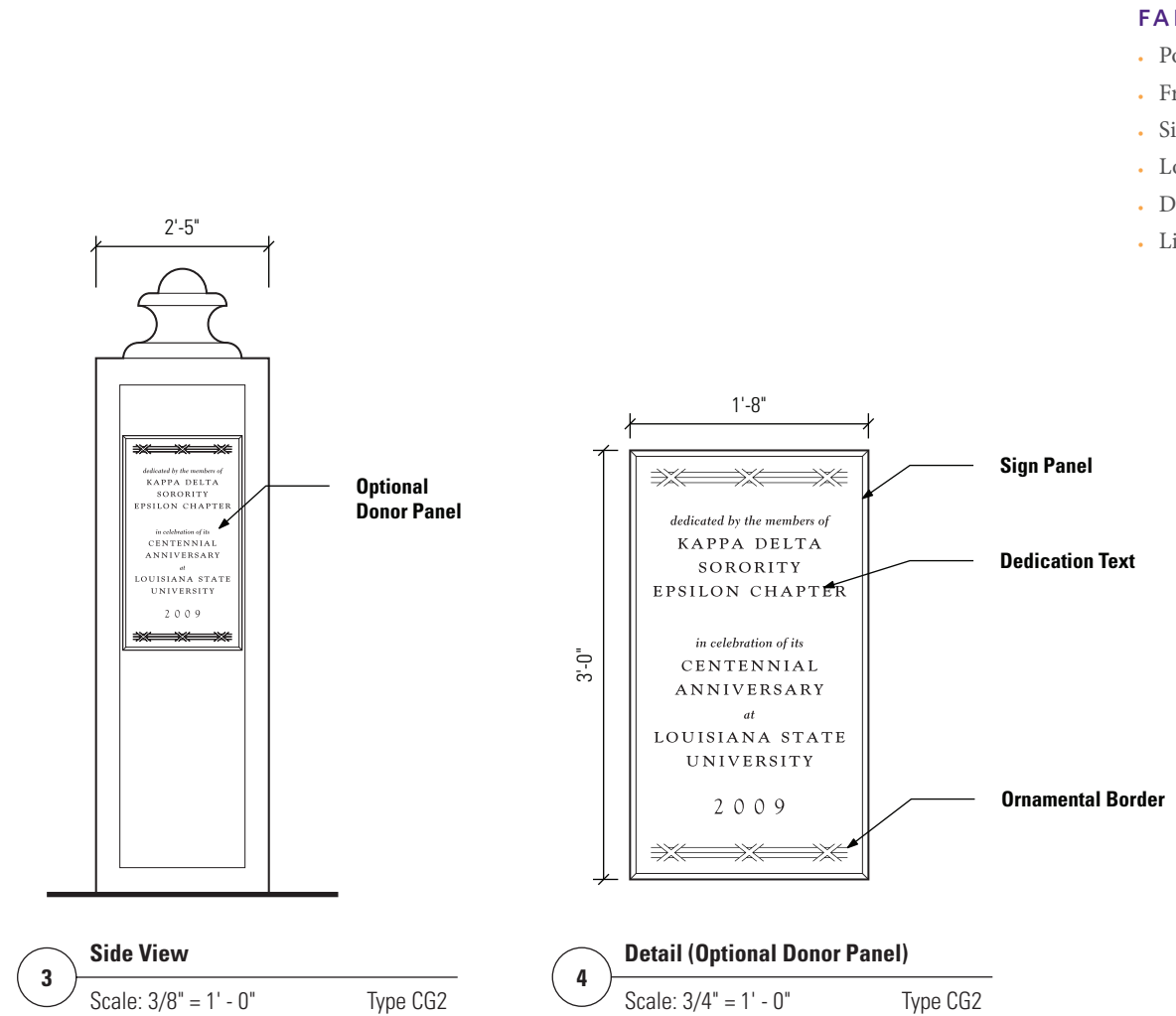
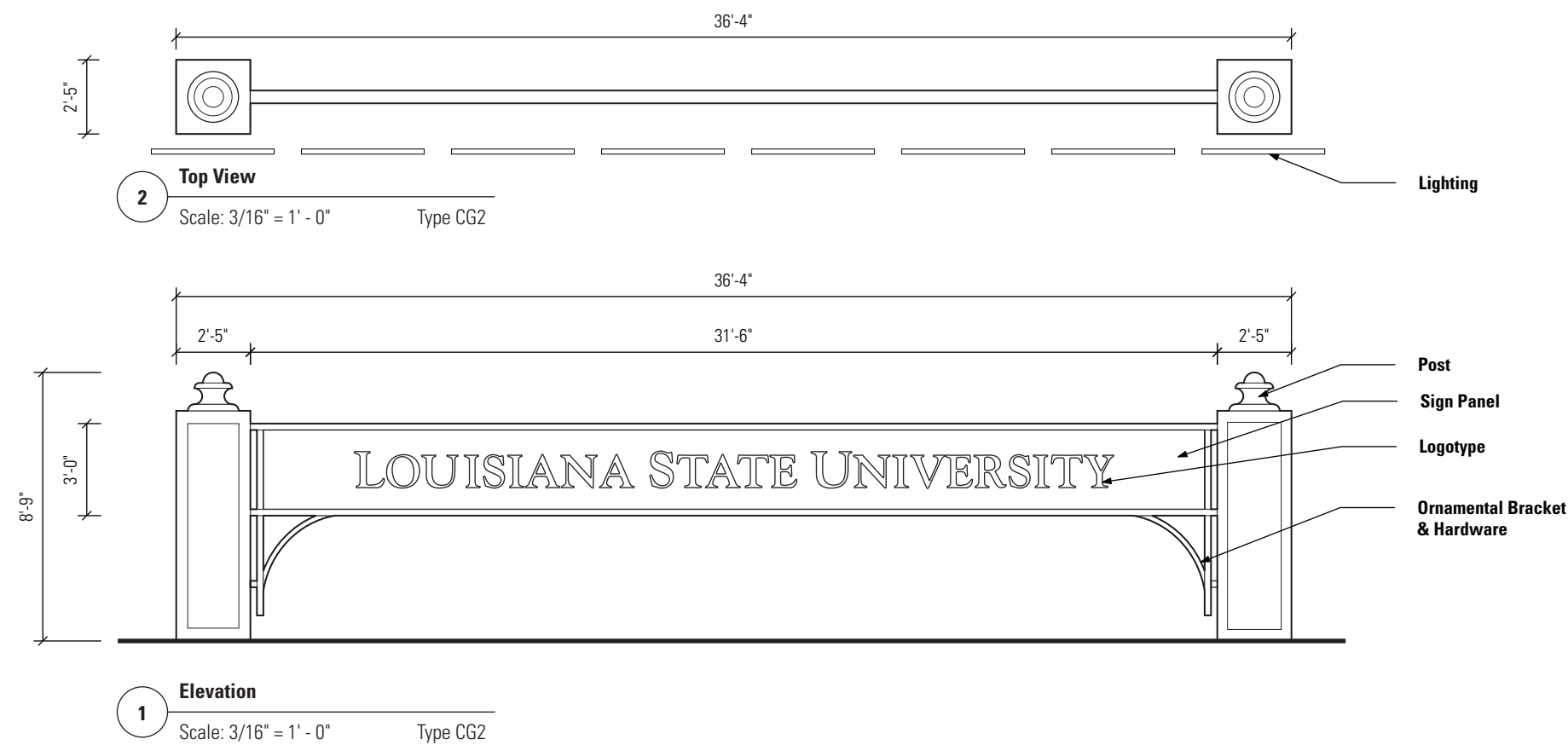

- FABRICATION DETAILS**
- Post: Architectural precast concrete with inset on 4 sides
 - Frame: 2 1/2" x 5" aluminum rectangular tube PC3
 - Sign Panel: 3" thick fabricated aluminum panel PC2
 - Logotype: 14" high 1/2" thick dimensional letters
 - Donor Panel: Cast bronze
 - Lighting: Concealed, ground-mounted, LED uplights

FABRICATION DETAILS

- Top Cap: formed aluminum “pyramidal” shape, AP3
- Display: full motion video LED matrix, final specifications and technology to be determined
- Logo: embossed /cast into concrete, no fill
- Sign Base: Pre-cast concrete, color and finish to match campus standards
- Lighting: Illuminate base only with concealed, ground-mounted, LED uplights

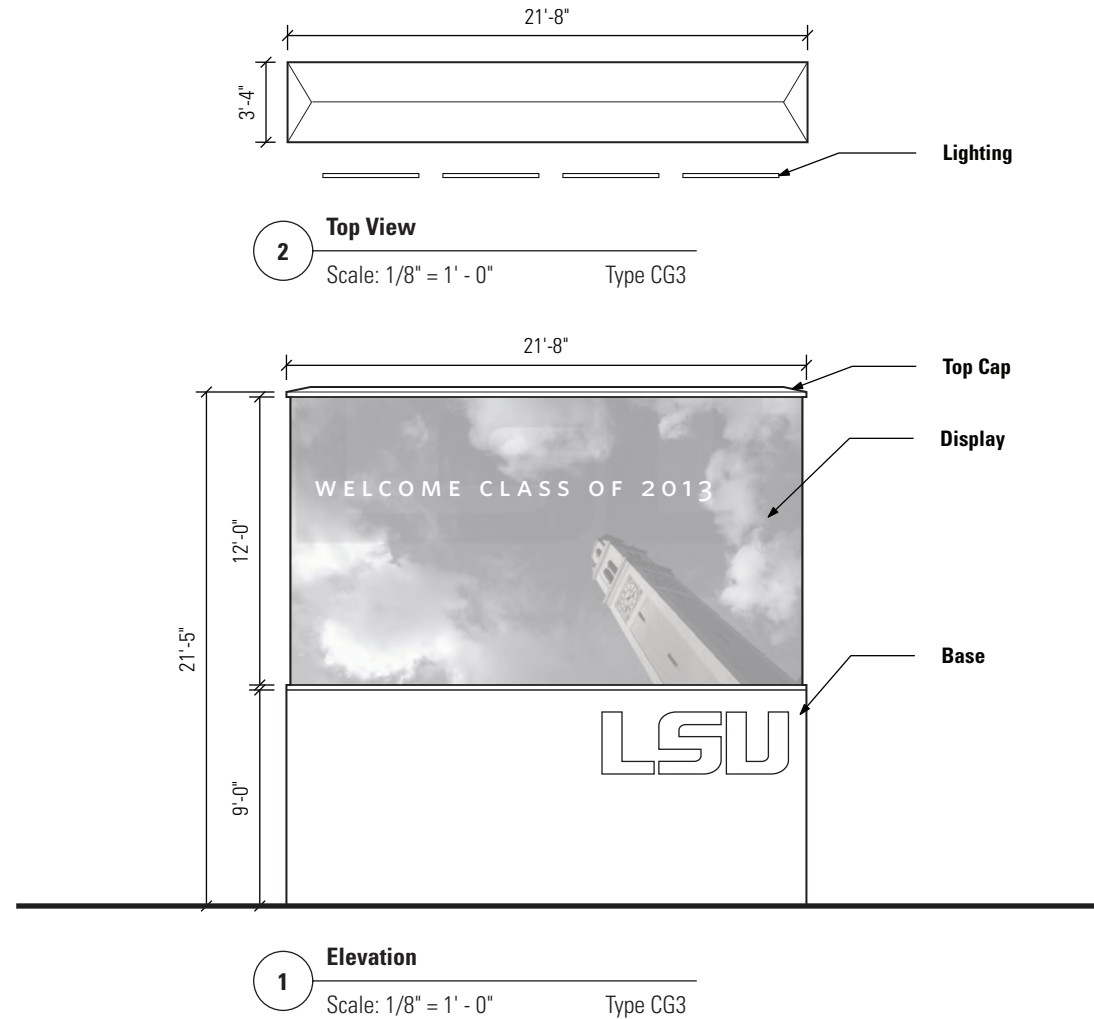

FABRICATION DETAILS

- Post: Architectural precast concrete with inset on 4 sides
- Frame: 4" high rolled aluminum tube PC3
- Sign Panel: 1' 2" thick fabricated aluminum panel PC2
- Logotype: 36" high 2" thick dimensional letters PC1
- Lighting: Illuminate sign panel and piers with flush, ground-mounted LED uplights

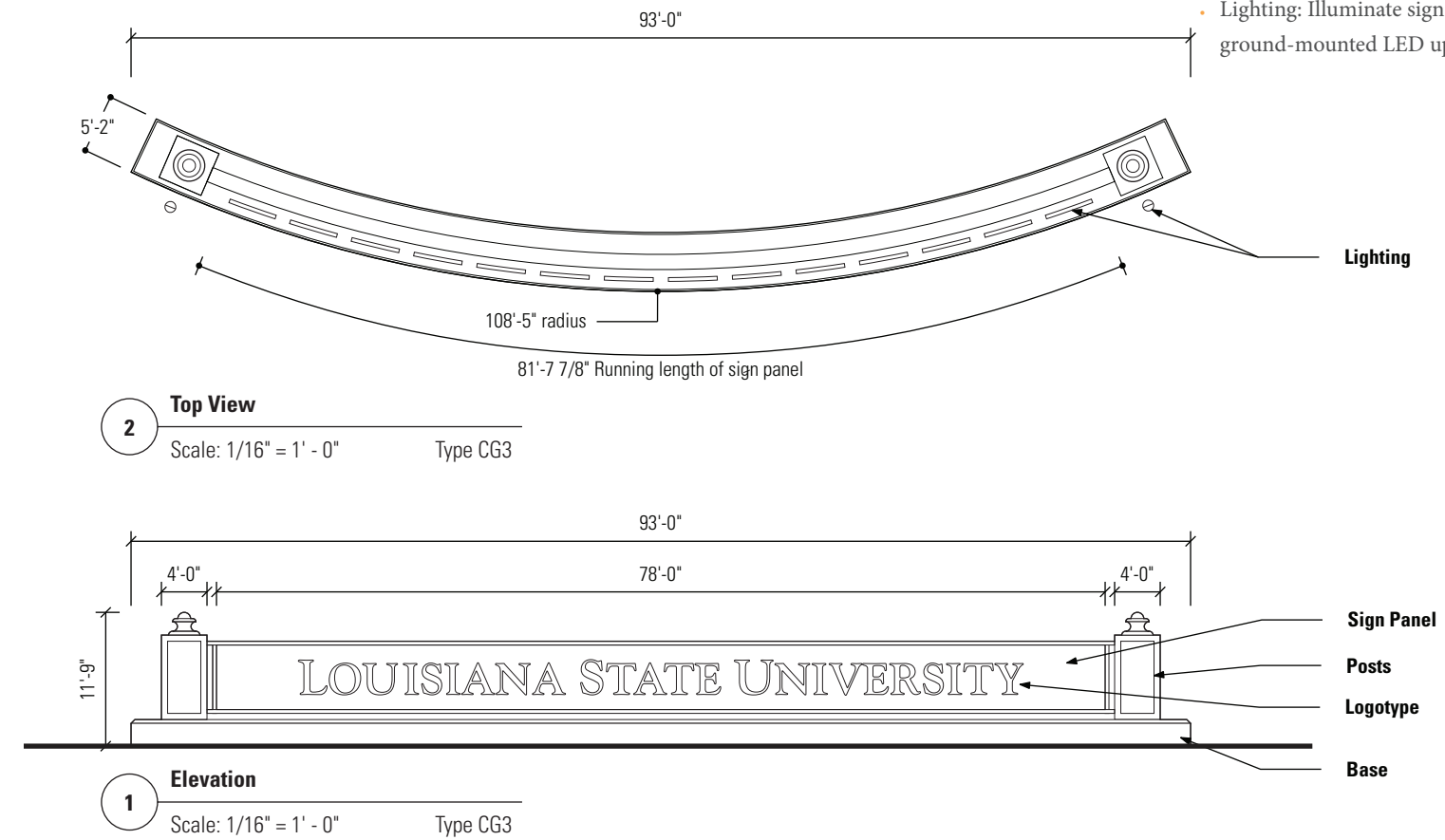

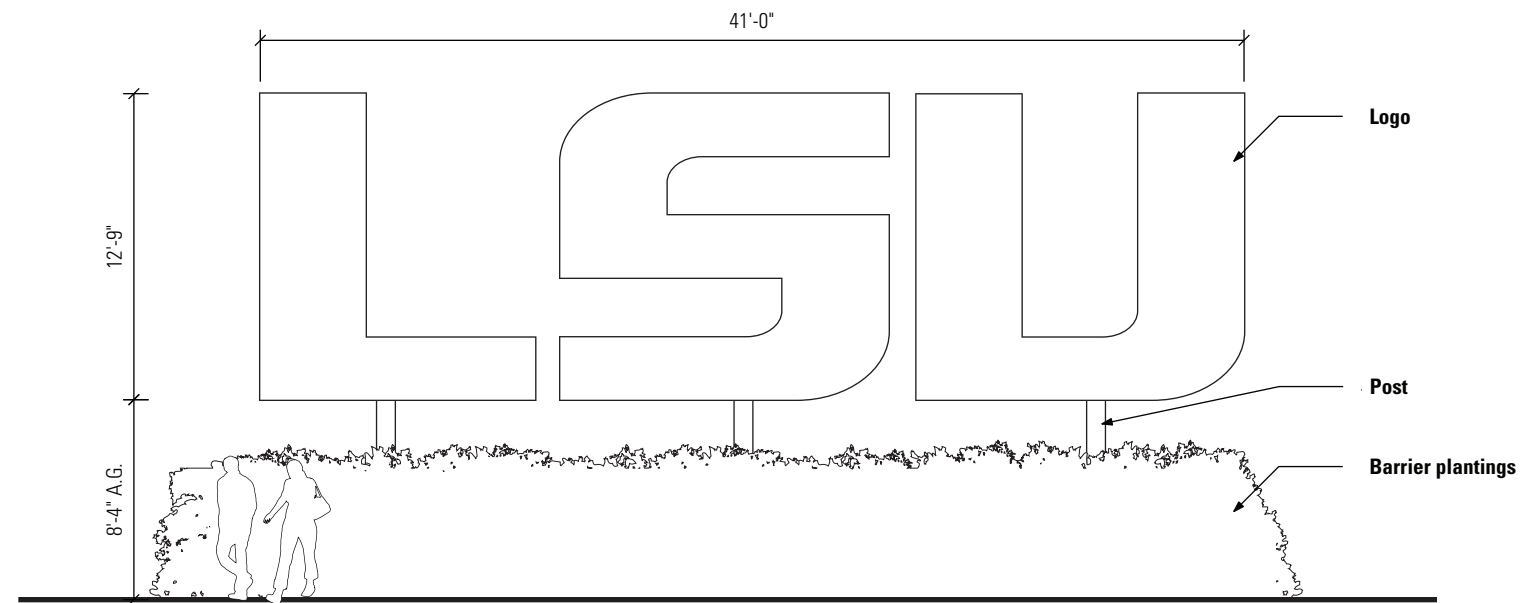

1 Elevation
Scale: 1/8" = 1' - 0" Type CG4

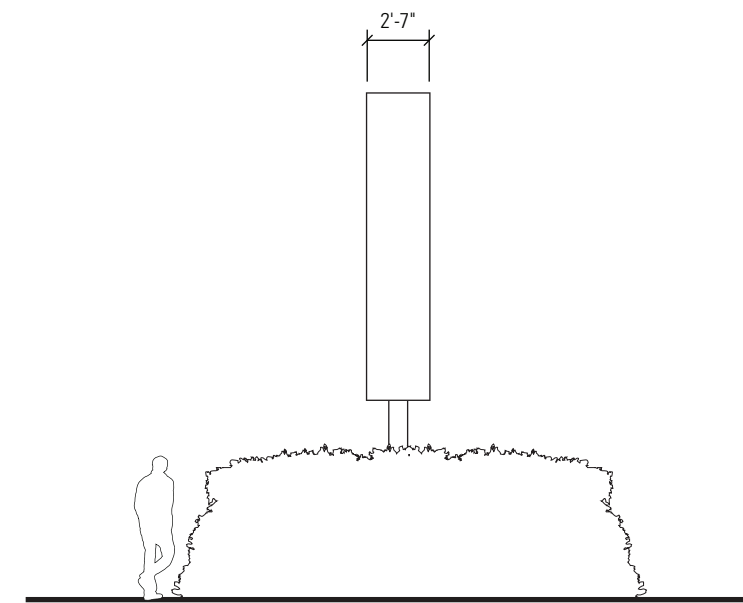

2 Side View
Scale: 1/8" = 1' - 0" Type CG4

FABRICATION DETAILS

- Logo (option 1) Fabricated aluminum with flush-to-face full motion video LED matrix display, final specifications and technology to be determined
- Logo (option 2) Fabricated aluminum with flush-to-face LED color changing matrix, final specifications and technology to be determined
- Logo (option 3) Fabricated aluminum, PC1 with illumination from concealed, ground-mounted LED spot lights
- Post: square steel, PC3, structurally engineered as required, accommodating power as required
- Plantings: to be determined - design intent is dense vegetation that will discourage access to logo while avoiding installation of a fence or other barrier(s)
- Suggested vegetation types could include Burford Holly or Chinese Holly ("Rotunda")

CK1

campus kiosk

PRIMARY, PEDESTRIAN PATHWAYS

FABRICATION DETAILS

- Finial: spun aluminum, custom profile, AP3
- Roof: Fabricated aluminum roof, AP3
- Downlights: flush-mounted, low voltage LED spots
- Sign Panel: fabricated aluminum sign cabinet, AP3
- Welcome Text: T5, AP4
- Logo: 12" h.
- Logotype: 1 1/2" h.
- Map Title: 2" h., T1
- Information Icon: 9" sq.
- Map and Directory: Digitally printed vinyl (option 1) or digital high pressure laminate (DHPL) panel (option 2)
- Sign Post: 4" sq. AP3
- Ornamental Bracket & Hardware: water-jet cut aluminum plate and aluminum extrusions, AP3
- Sign Base: post and sleeve sidewalk condition

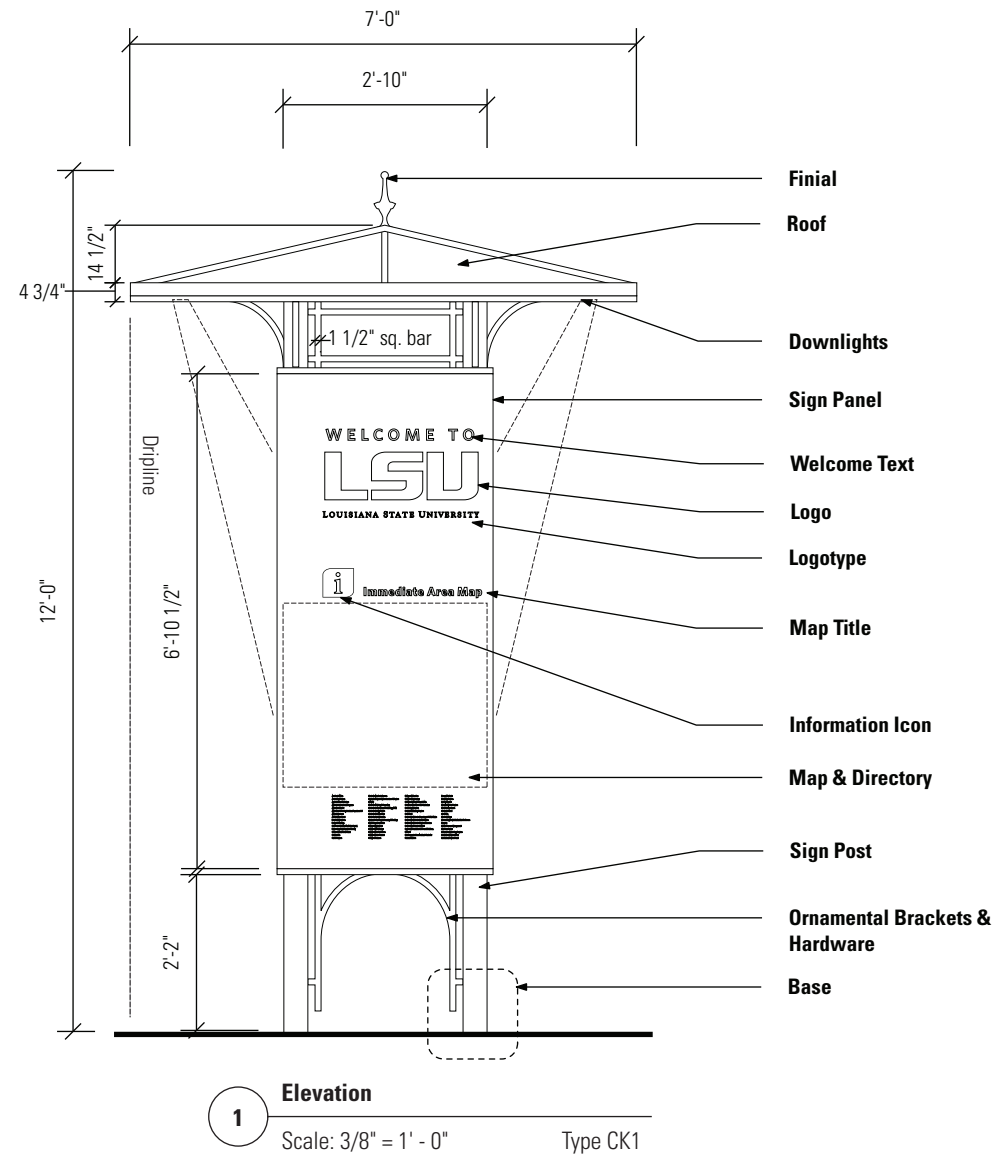

CK2

campus kiosk

SMALL, PARKING LOTS AND PATHWAYS

FABRICATION DETAILS

- Top Cap: Fabricated aluminum "pyramidal" shape, AP3
- Accent: match AP2, T5, match AP1
- Information Icon: White, and match AP1, AP2
- Sign Panels: AP1 (front, back and sides) with .5" digital high pressure laminate (DHPL) panels or digitally printed vinyl
- Map and directory: Digital artwork
- Logo: match AP2
- Ornamental Bracket & Hardware: water-jet cut aluminum plate and aluminum extrusions: AP3
- Sign Post: 4" sq., aluminum extrusion: AP3
- Sign Base: below grade

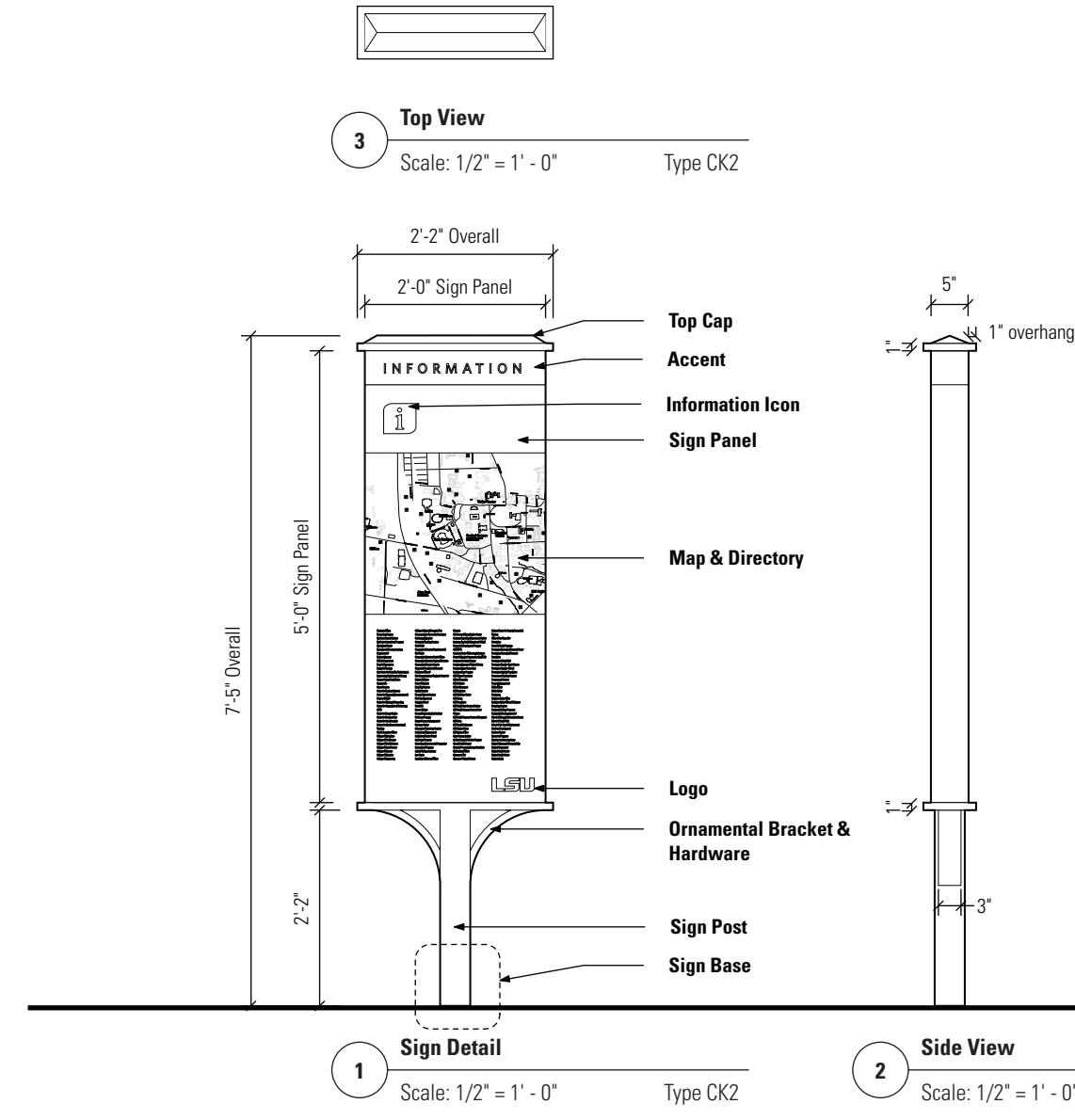

campus shuttle

FABRICATION DETAILS

- Finial: custom, cast aluminum or resin, AP3
- Trails logo: (per specs)
- Rule: V3
- Street Name: T1, V2
- Routes: (digital print on vinyl) T7
- Sign Panel: .25" aluminum plate, AP1
- Website: T2, V2
- Sign Post: 4" sq. aluminum extrusion, AP3
- Sign Base: below grade, sleeve

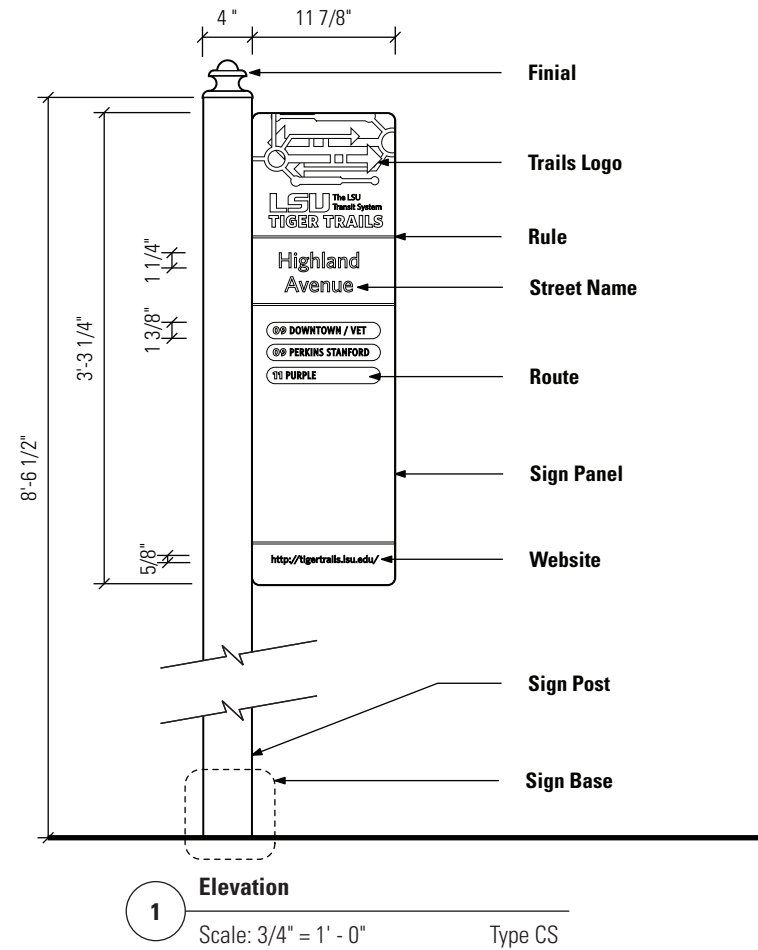

vehicular directional

OFF-CAMPUS ROADWAYS

FABRICATION DETAILS

- Top Cap: aluminum formed "pyramidal" shape, AP3
- Visitor Header: AP3
- Thick Rule: 1 5/8" h., V3
- Sign Panel: fabricated aluminum sign cabinet, AP1
- Tier 1 Text: 7" h., 14" line spacing, T1, V2
- Tier 2 Text: 6 1/4" h., 11 1/4" line spacing, T3, V2
- Thin Rule: 3/8" h., V3
- Arrow: 10 1/2" sq., V1
- Raised Bar: aluminum extrusion, AP3
- Logo: embossed /cast into concrete, no fill
- Sign Base: Pre-cast concrete, color and finish to match campus standards
- Pattern: Mask and spray Pantone 2587 on AP1, or digital print Pantone 2587 on AP1.

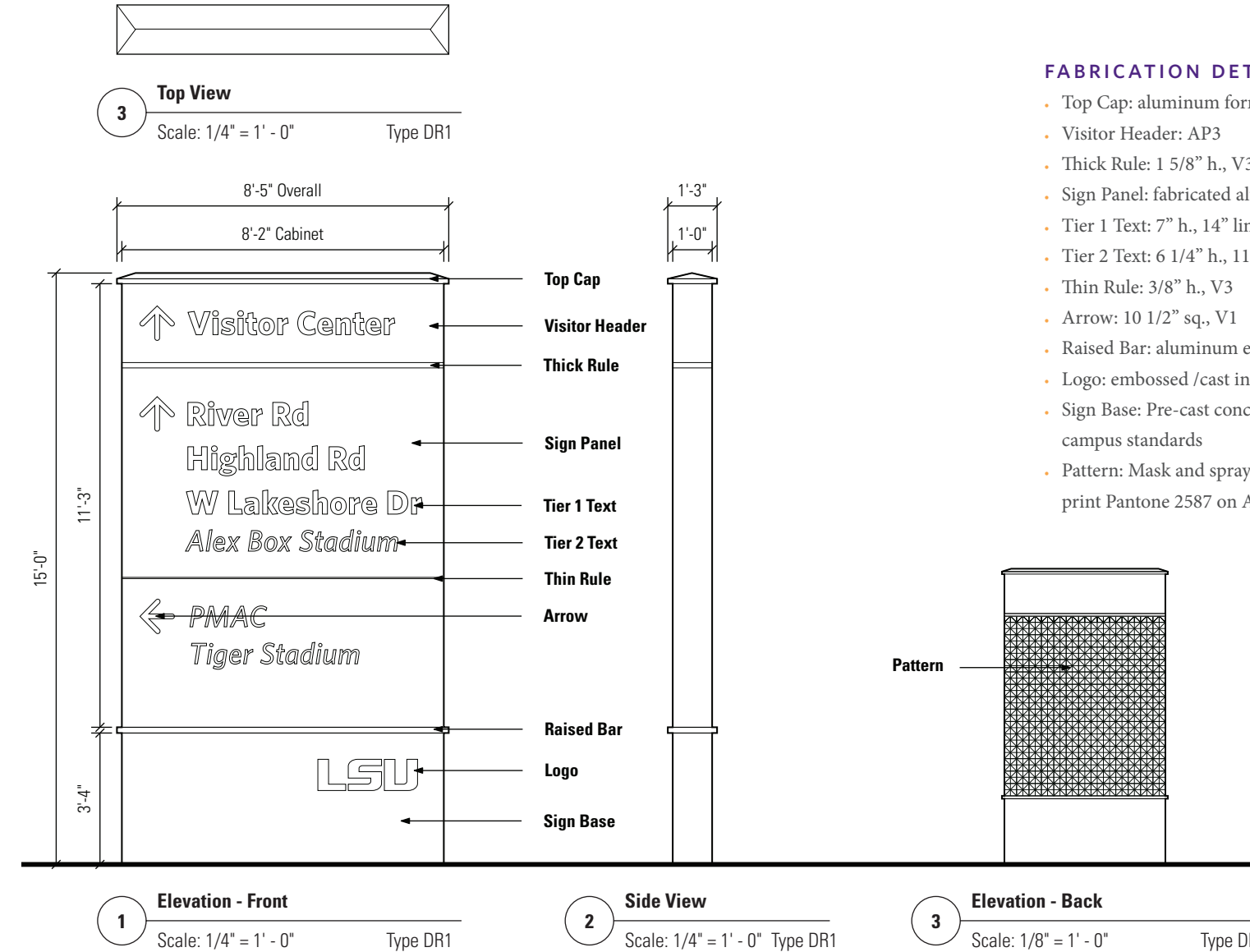

vehicular directional

ON-CAMPUS

FABRICATION DETAILS

- Finial: Cast or spun aluminum or approved equal, AP3
- Top Cap: Fabricated aluminum “pyramidal” shape, AP3
- Visitor Header: AP3
- Thick Rule: 1” h. V3
- Regulatory Text: 1 5/8” h., T5, V2
- Thin Rule: 1/4” h., V3
- Tier 1 Text: 4” h., 8” line spacing, T1, V2
- Arrow: 6 1/4” sq., V1
- Sign Panel: Fabricated 3” th. aluminum cabinet with 1/8” th. removable aluminum sign faces, AP1
- Tier 2 Text: 3 1/2” h., 6 1/2” line spacing, T3, V2
- Logo: 3 3/4” h., V3
- Ornamental Bracket & Hardware: water-jet cut aluminum plate and aluminum extrusions, AP3
- Sign Post: 6” sq. aluminum extrusion, AP3
- Sign Base: post-in-sleeve or breakaway, AP3

entry identity

WALL PLAQUE

FABRICATION DETAILS

- Accent: tactile, AP2
- Facility Name: 5/8” h., 1/32” raised T2, AP4 with grade 2 braille translation AP1
- Sign Panel: .25” etched zinc, AP1, with .25” aluminum mounting plate, AP3
- Logo: 3/4” h., 1/32” raised, AP2
- Rule: 1/4” h., 1/32” raised, AP2
- Accessibility Panel: AP1
- Arrow: 1 1/2” h., V8
- Access Symbol: 2 5/8” h., 1/32” circle, V5, symbol, V8
- Entry Designation: 1/2” h., T3, V8

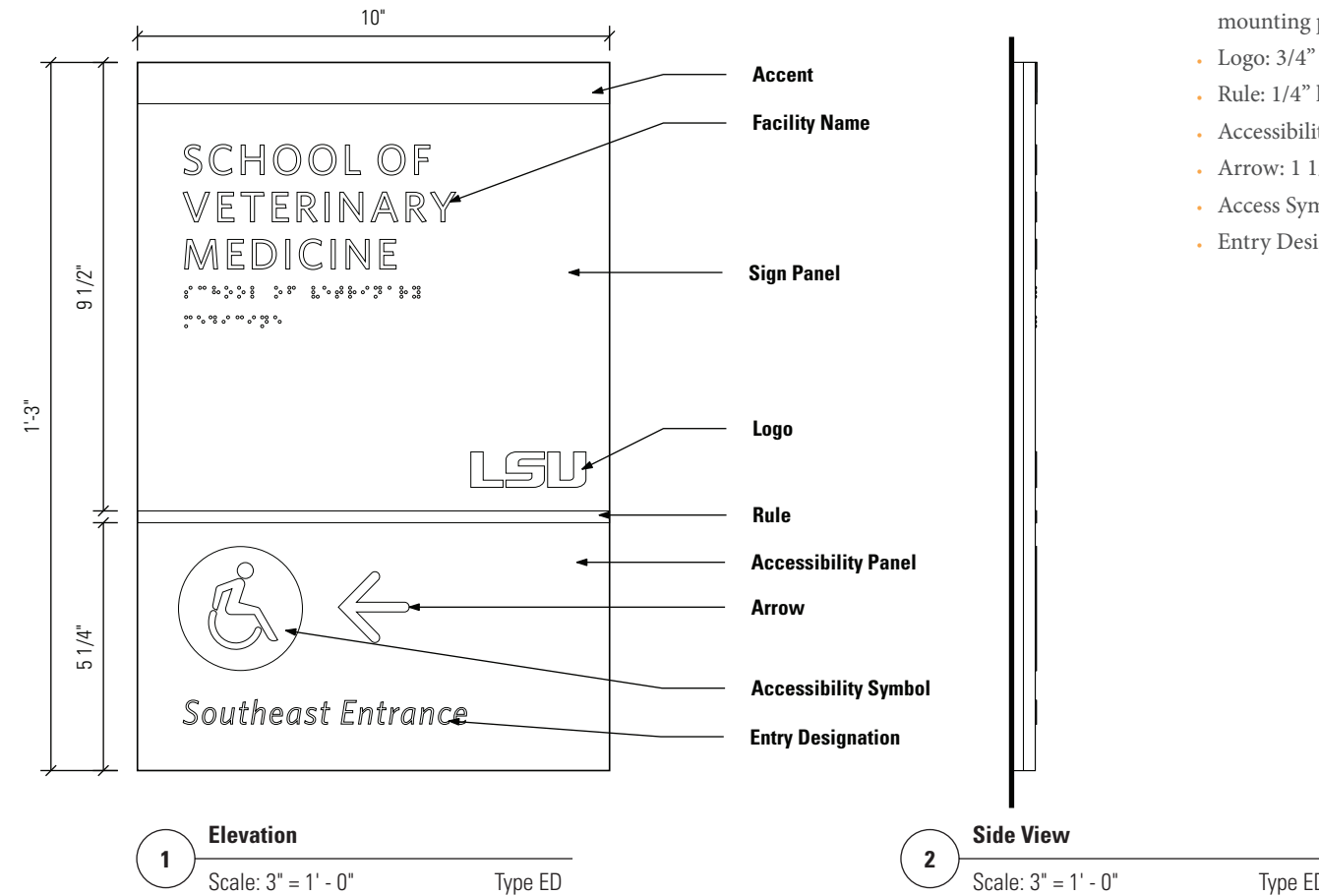

EV1

event temporary

DIRECTIONALS

FABRICATION DETAILS

- EV1A
- Parking Zone: 1' - 3 1/2" h., V1, 6" h. number, T8, V1
- Sign Panel: .090" aluminum panel, AP1 all sides
- Arrow: 5" sq. V1
- Sign Post: 4" sq. aluminum extrusion. AP3
- Sign Base: concrete, AP3
- EV1B
- Mobile LED Display w/ Trailer
- Aspect Ratio: 16:9
- Display: full motion video LED matrix, final specifications and technology to be determined

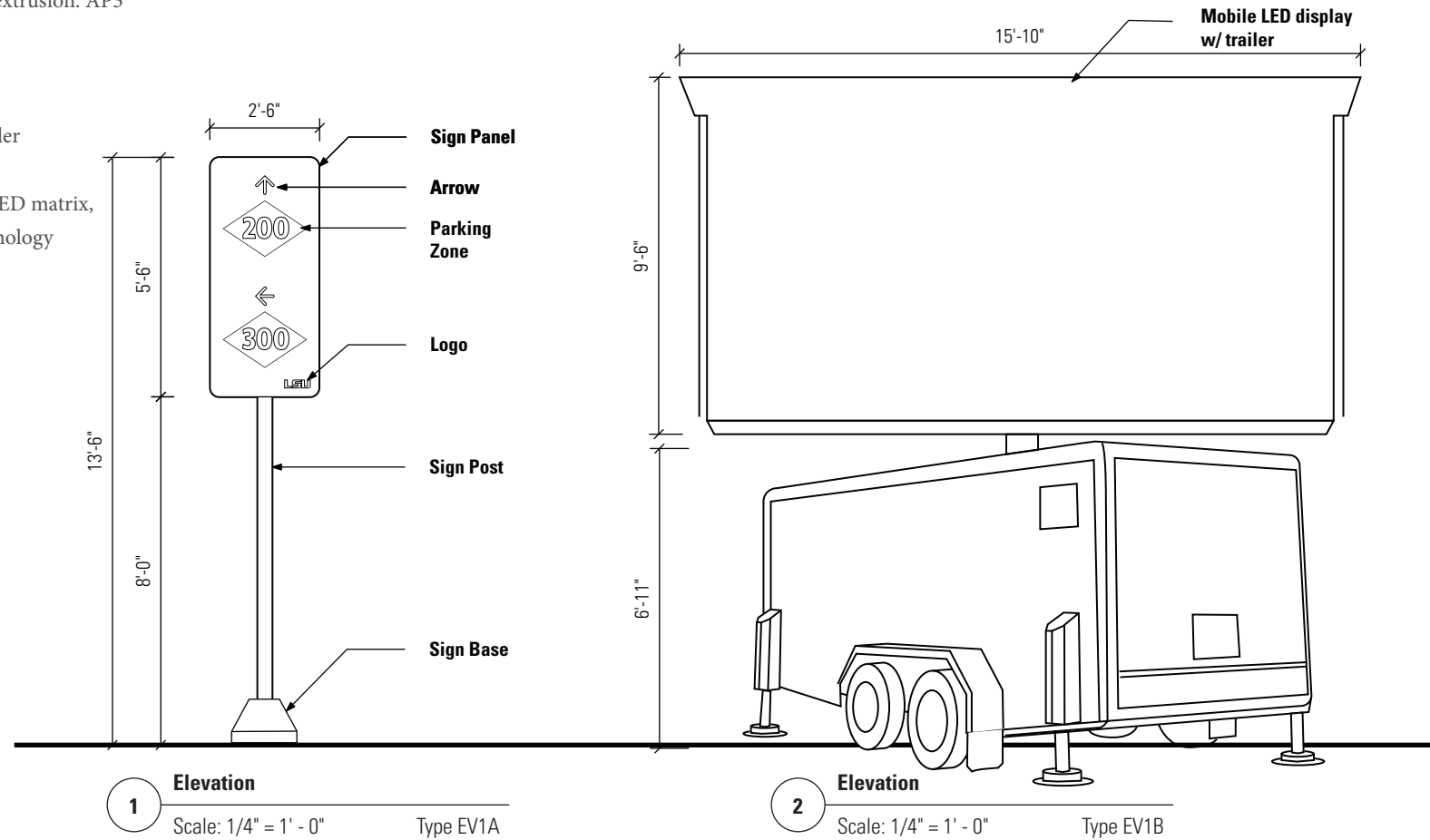

EV2

event temporary

IDENTITY

FABRICATION DETAILS

- EV2A
- Parking Zone: 1' - 3 1/2" h., V1, 6" h. number, T8, V1
- Sign Panel: .090" aluminum panel, AP1 all sides
- Arrow: 5" sq. V1
- Lot Name: 2 1/2" h., V1, T7
- Sign Post: 4" sq. aluminum extrusion. AP3
- Sign Base: concrete, AP3
- EV2B
- Parking Zone: 2' - 0", V1, 9 1/2" h., number, T8
- Sign Panel: .090" aluminum panel, all sides AP1
- Lot Name: 3 1/5" h., V1, T7
- A-Frame: Black
- Logo: 3 1/4" h., V1

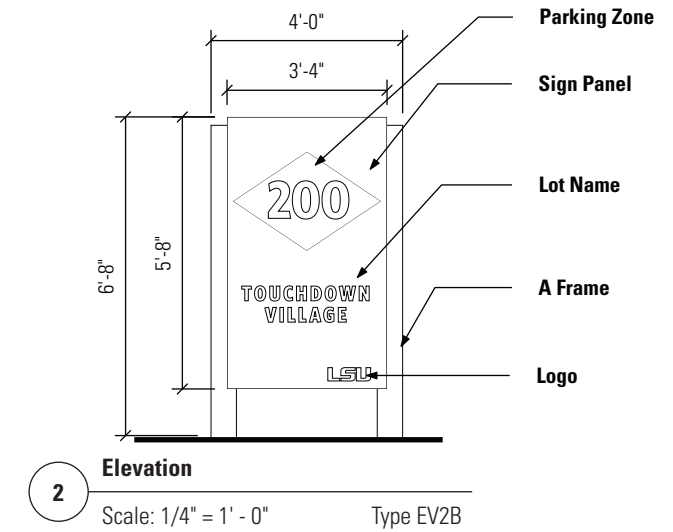
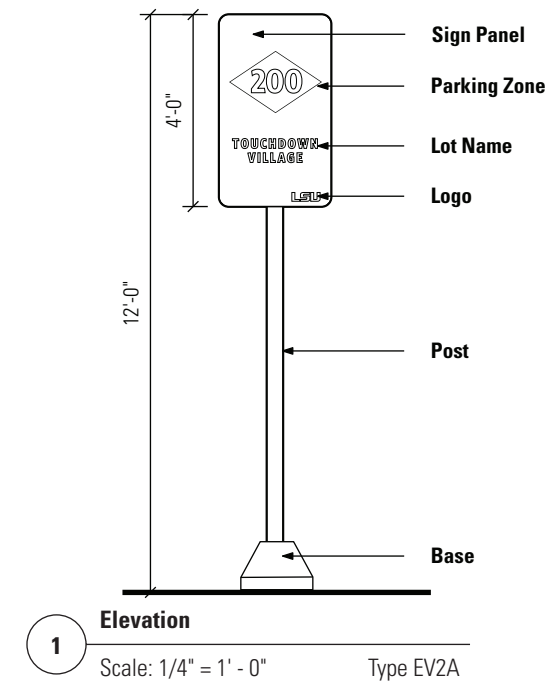

EV3

event temporary

REGULATORY

FABRICATION DETAILS

- EV3A
- Barricade: Polypropelene modular inetlocking barrier to match PMS 143
- EV3B
- Parking Zone: 1' - 3 1/2" h. V1, 6" h., number, T8
- Sign Panel: .090" aluminum panel, all sides AP1
- Lot Name: 2 3/8" h. V1, T7
- A-Frame: Black
- Logo: 3 1/8" h., V1
- Regulatory 1: 1 1/8" h. T3, V2
- Regulatory 2: 1 1/2" h., T5, V2
- EV3C
- Parking Zone: 9" sq field, with 6" h., character T4, V2, backgrounds, V7-14
- Headline: 1 1/4" h., V2
- Subhead: 7/5" h., T3, V1
- Arrow: 5 1/8" sq., V1
- Sign Panel: 1/8" aluminum plate, AP1
- Sign Base: below Gorilla Post

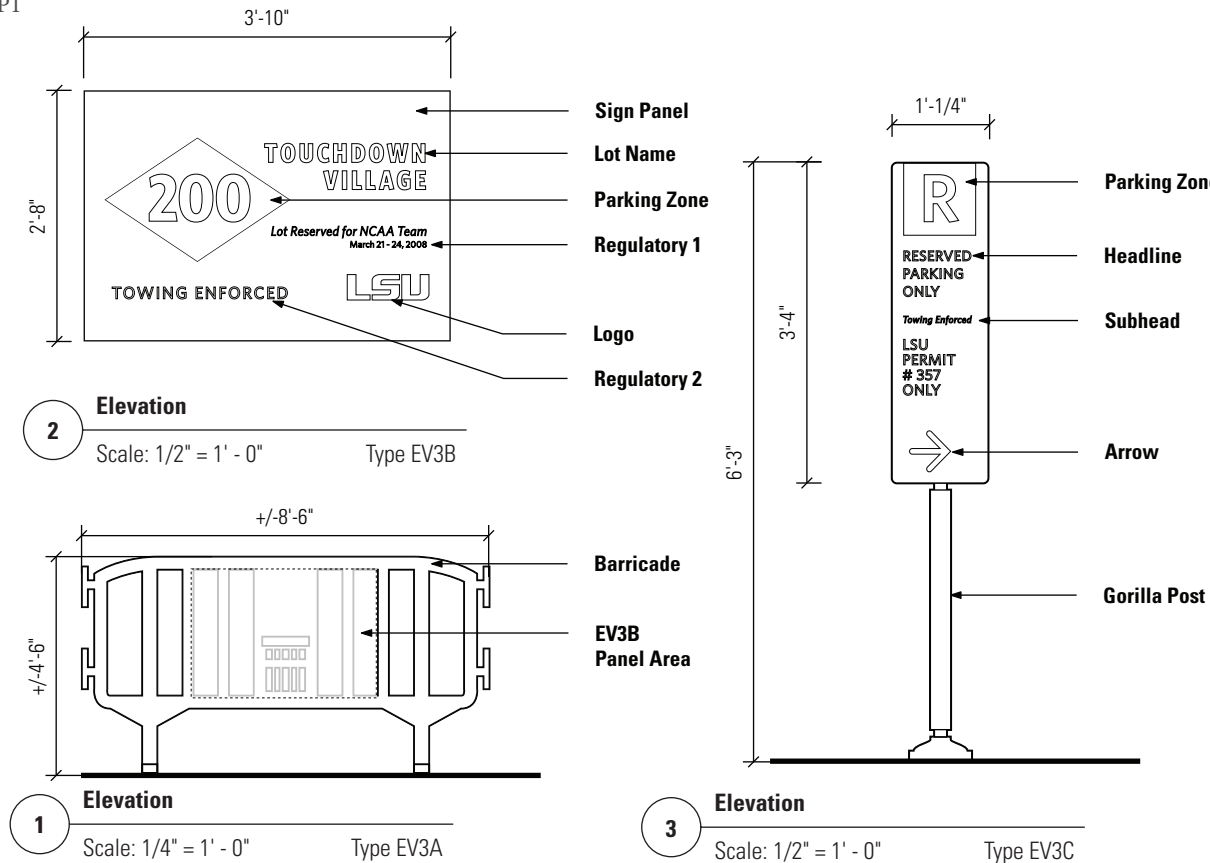

FA1

facility identity

LARGE, FREESTANDING

FABRICATION DETAILS

- Finial: Cast or spun aluminum or approved equal, AP3
- Top Cap: Fabricated aluminum "pyramidal" shape, AP3
- Accent: 1 1/4" h., V3
- Facility Name: 4 1/8" h., T1, V8
- Date: 1 1/8" h., T5, V3
- Sign Panel: Fabricated 2" th. aluminum cabinet with 1/8" th. removable aluminum sign faces, AP1
- School: 2 1/8" h., T3, V8
- LSU Logo: 7" h., V3
- Affiliate Logo: 7" h., V4
- Ornamental Bracket & Hardware: water-jet cut aluminum plate and aluminum extrusions, AP3
- Sign Post: 4" sq. aluminum extrusion, AP3
- Sign Base: above grade (lawn) or below grade (planting bed)

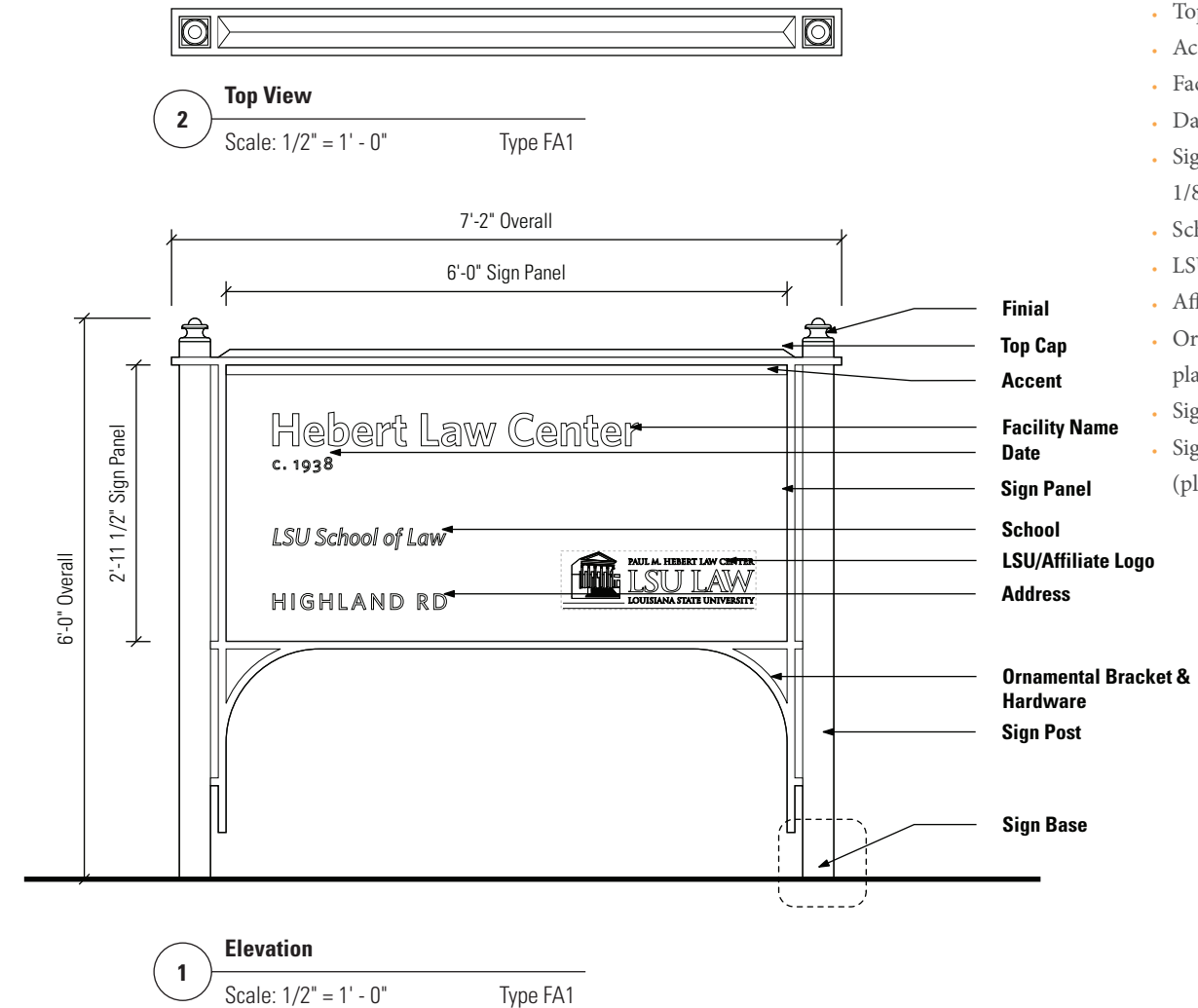

FA2

facility identity

SMALL, FREESTANDING

FABRICATION DETAILS

- Finial: Cast or spun aluminum or approved equal, AP3
- Top Cap: Fabricated aluminum “pyramidal” shape, AP3
- Accent: 1” h., V3
- Facility Name: 2 3/4” h., T1, V8
- Date: 1 1/8” h., T5, V3
- Sign Panel: Fabricated 2” th. aluminum cabinet with 1/8” th. removable aluminum sign faces, AP1
- Logo: 2.75” h., V3
- Address: 1 1/8” h., T5, V3
- Ornamental Bracket & Hardware: water-jet cut aluminum plate and aluminum extrusions, AP3
- Sign Post: 4” sq. aluminum extrusion, AP3
- Sign Base: above grade (lawn) or below grade (planting bed)

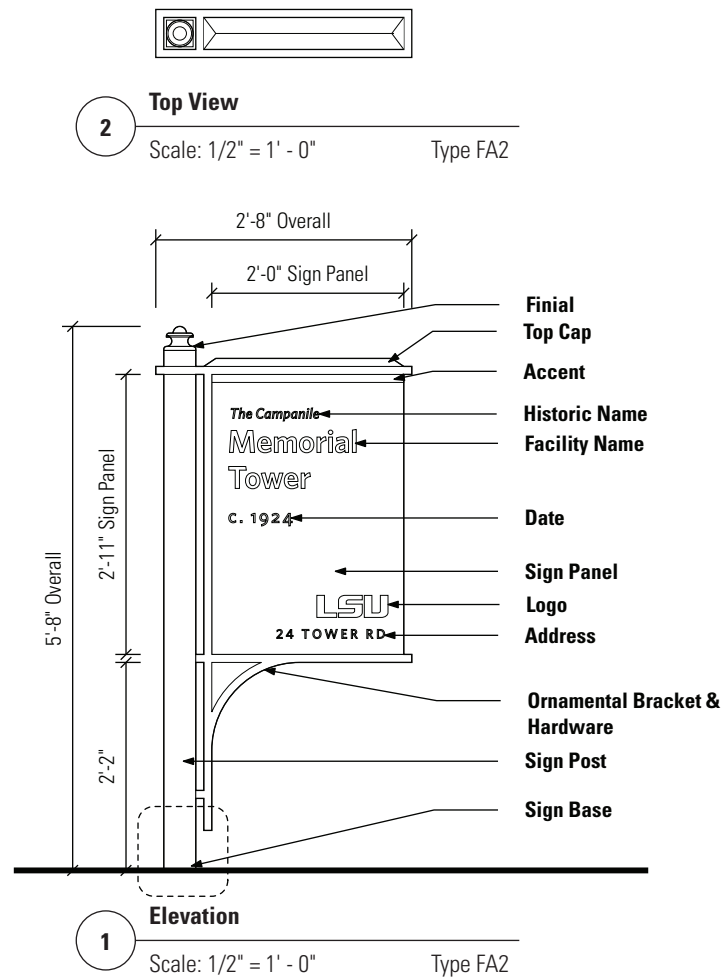

FA3

facility identity

BUILDING MOUNTED

FABRICATION DETAILS

- Backplate: 1/2” aluminum plate with 1/8” beveled edge, AP3
- Accent: 7/8” h., V3
- Facility Name: 2 5/8” h., 4 1/4” line spacing, T1, V8
- Date: 1 1/8” h., T5, V3
- Sign Panel: .25” aluminum plate, AP1
- LSU Logo: 2 3/4” h., V3
- Affiliate Logo: 2 3/4” h., V4
- Address: 1” h., T5, V3
- Mount backplate to wall with blind threaded studs.
- Faceplate mounted to backplate with full coverage VHB tape

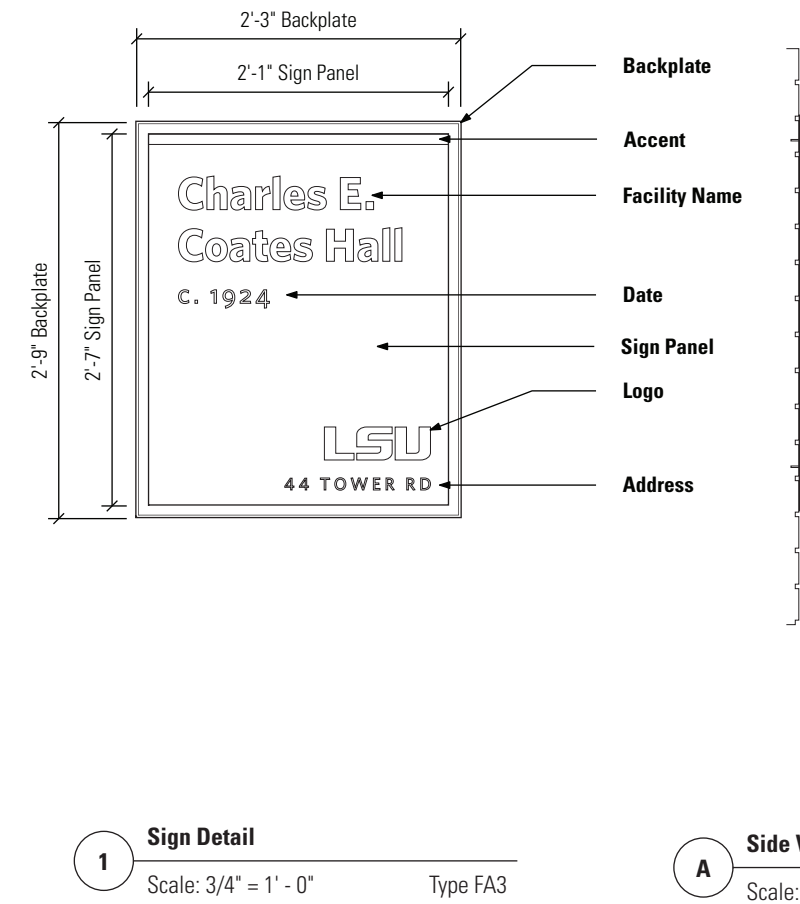

GE1

gated entry

WELCOME SIGN

FABRICATION DETAILS

- Top Cap: Fabricated aluminum "pyramidal" shape, AP3
- Finial: Cast or spun aluminum or approved equal, AP3
- Welcome Text: 2 1/4" h., T5, V2
- Accent: V3
- Area Name: 4 1/4" h., T2, V2
- Logo: 4 1/4" V1
- Sign Panel: Fabricated 3" th. aluminum cabinet with 1/8" th. removable aluminum sign faces, AP1
- Parking Regulatory: 2 1/2" h., T3, V2 1 3/8" h., T6 V2,
- Sign Post: 4" sq. aluminum extrusion: AP3
- Ornamental Bracket & Hardware: water-jet cut aluminum plate and aluminum extrusions: AP3
- Sign Base: above grade (lawn) or below grade (planting bed)

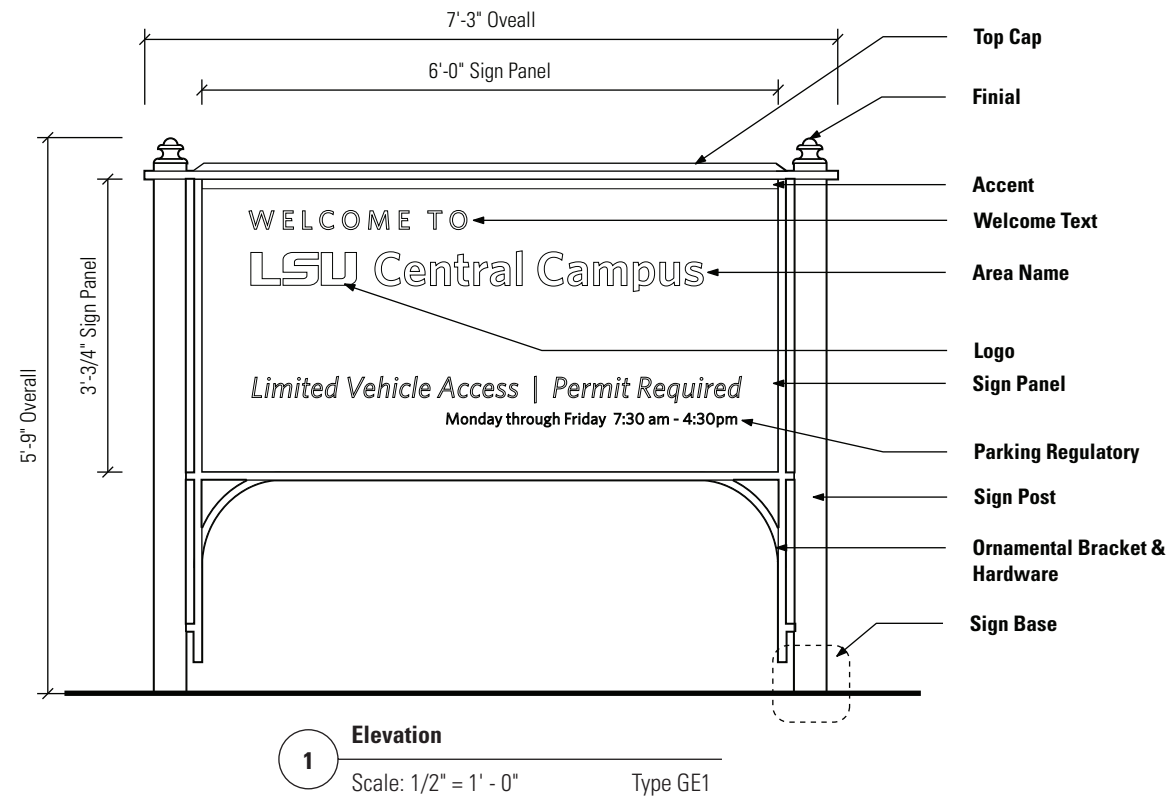

GE2

gated entry

GATE NAME

FABRICATION DETAILS

- Accent: 2" h., V3
- Logo: 5 3/4" h., V1
- Logotype: 3/4" h., V1
- Street: 2 1/2" h, T2, V2
- Gate: 2 1/2" h, T5, V2
- Sign Panel: fabricated aluminum sign cabinet, AP3
- Bracket: aluminum extrusions: AP3

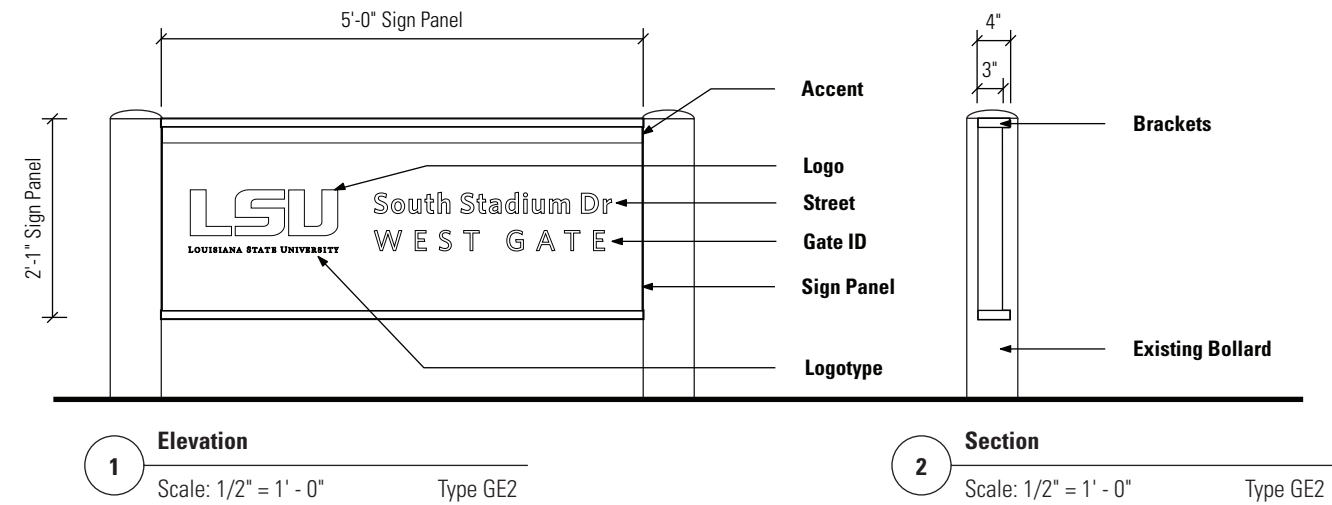

IN1

interpretive

FREESTANDING

FABRICATION DETAILS

- Top Cap: Fabricated aluminum “pyramidal” shape, AP3
- Sign Panel: .5” digital high pressure laminate (DHPL) panel
- Ornamental Bracket & Hardware: water-jet cut aluminum plate and aluminum extrusions: AP3
- Sign Post: 4” sq., aluminum extrusion: AP3
- Sign Base: above grade (lawn) or below grade (planting bed)

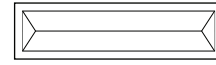

3 Top View
Scale: 1/2" = 1' - 0" Type IN1

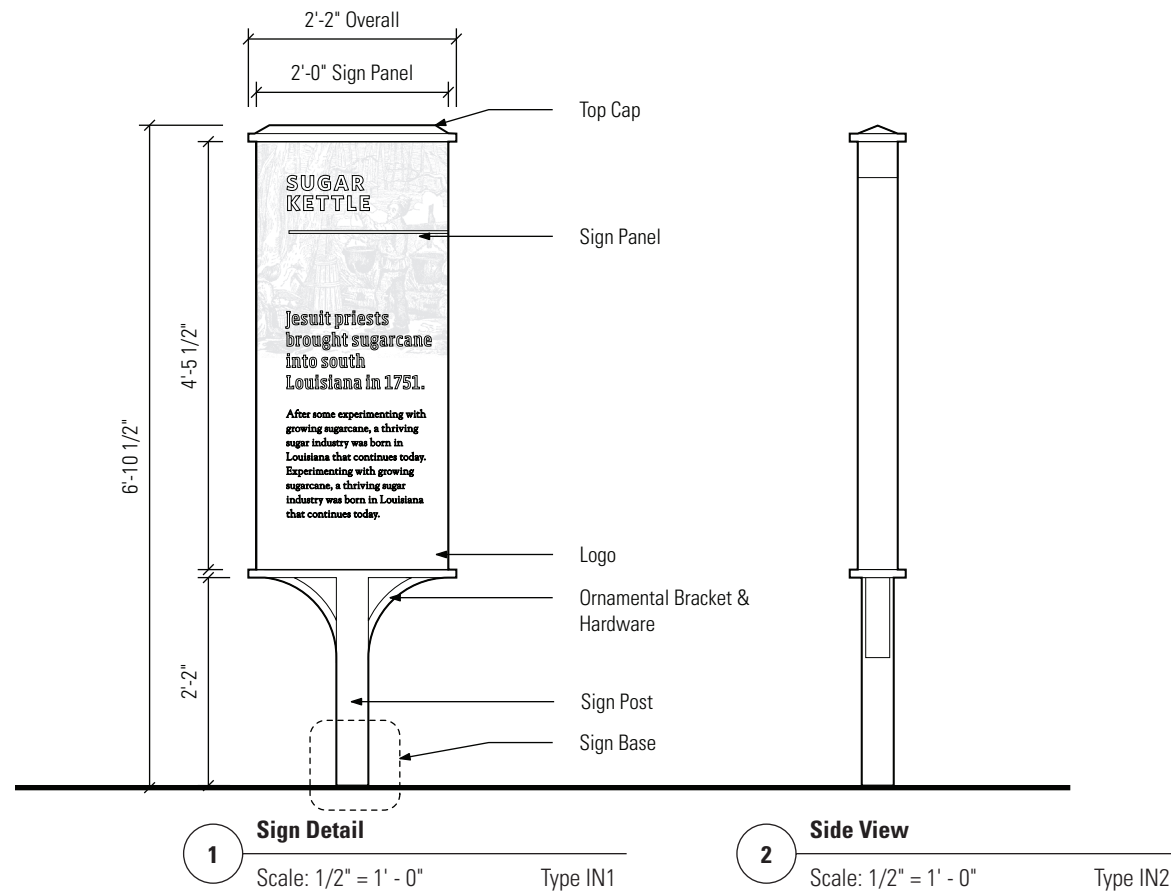

1 Sign Detail
Scale: 1/2" = 1' - 0" Type IN1

2 Side View
Scale: 1/2" = 1' - 0" Type IN2

IN2

interpretive

BUILDING MOUNTED

FABRICATION DETAILS

- Sign Panel: .5” digital high pressure laminate (DHPL) panel
- Bracket & Hardware: water-jet cut aluminum plate and aluminum extrusions: AP3
- Mount brackets to wall with blind threaded studs

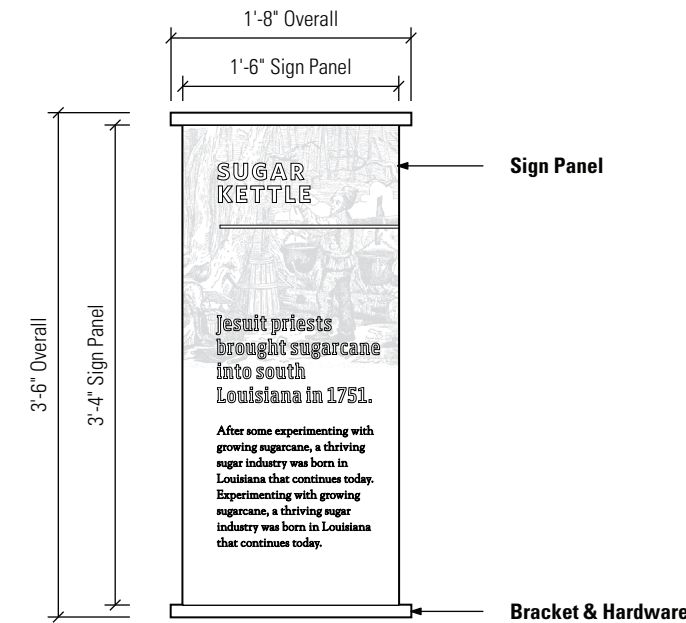

1 Elevation
Scale: 3/4" = 1' - 0" Type IN2

PK1

parking

STRUCTURED

FABRICATION DETAILS

- Top Cap: Top Cap: Fabricated aluminum “pyramidal” shape, AP3
- Parking Icon: 1’ - 9 1/2” sq. field, letters and numerals T4, V2, backgrounds, V7-14
- Accent: 2” w. V3 wraps edge
- Facility Name: 8 1/2” h., V2, T1
- Sign Panel: Fabricated 3” th. aluminum cabinet with 1/8” th. removable aluminum sign faces, AP1
- Facility Number: 2” h., Pantoine 2587, T6
- Ornamental Bracket & Hardware: water-jet cut aluminum plate and aluminum extrusions, AP3

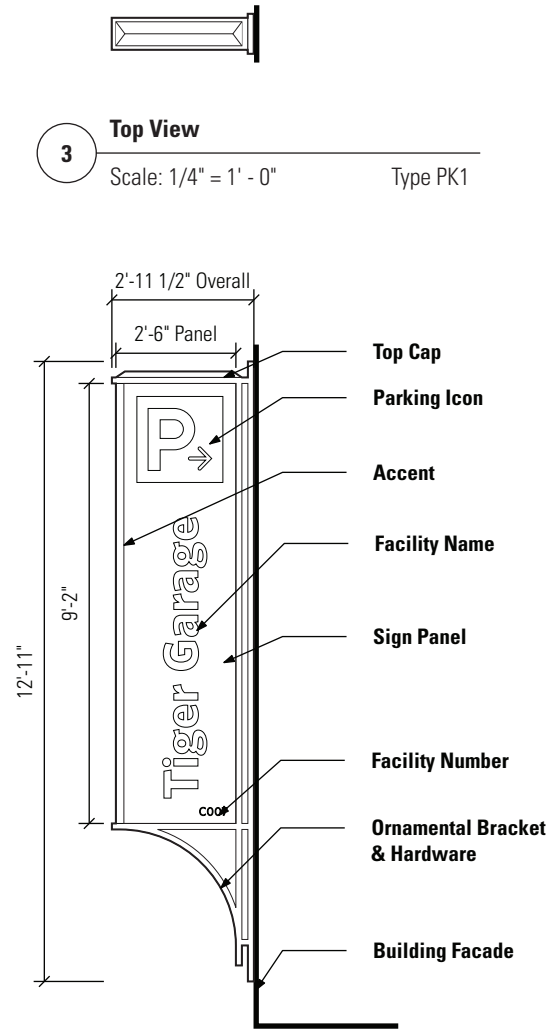

3 Top View
Scale: 1/4" = 1' - 0" Type PK1

1 Elevation
Scale: 1/4" = 1' - 0" Type PK1

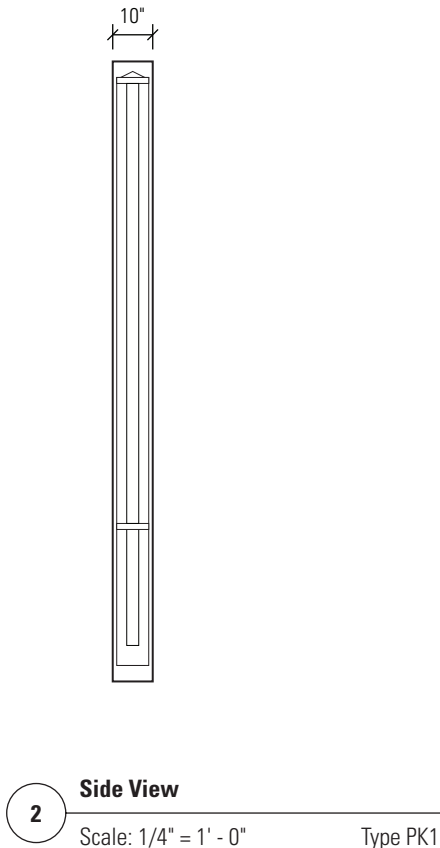

2 Side View
Scale: 1/4" = 1' - 0" Type PK1

PK2

parking

SURFACE LOT

FABRICATION DETAILS

- Top Cap: Fabricated aluminum “pyramidal” shape, AP3
- Accent: 2 1/4” h., V3
- Event Parking Panel: pre-drilled .090” aluminum with keyhole slots pre-painted AP2, message V9. Event panel slips over and onto studs projecting from Sign Panel. Event panels to be stocked by LSU Office of Parking, Traffic, and Transportation and the LSU Athletic Department
- Tier 1 Text: 4” h., 7” line spacing. T1, V2
- Rule(s): 1/2” h., V3
- Parking Zones: 3 1/4” h; letters and numerals, V2, 5” sq; backgrounds, V7-14
- Parking Regulations: V2, 2” h, T3 & 1 1/4” h. T6
- Lot Number: 1 7/8” h., V4, T6
- Logo: 3 1/4” h., V3
- Sign Panel: fabricated aluminum sign cabinet, AP1
- Raised Bar: aluminum extrusion, AP1
- Sign Base: fabricated aluminum sign cabinet, AP1

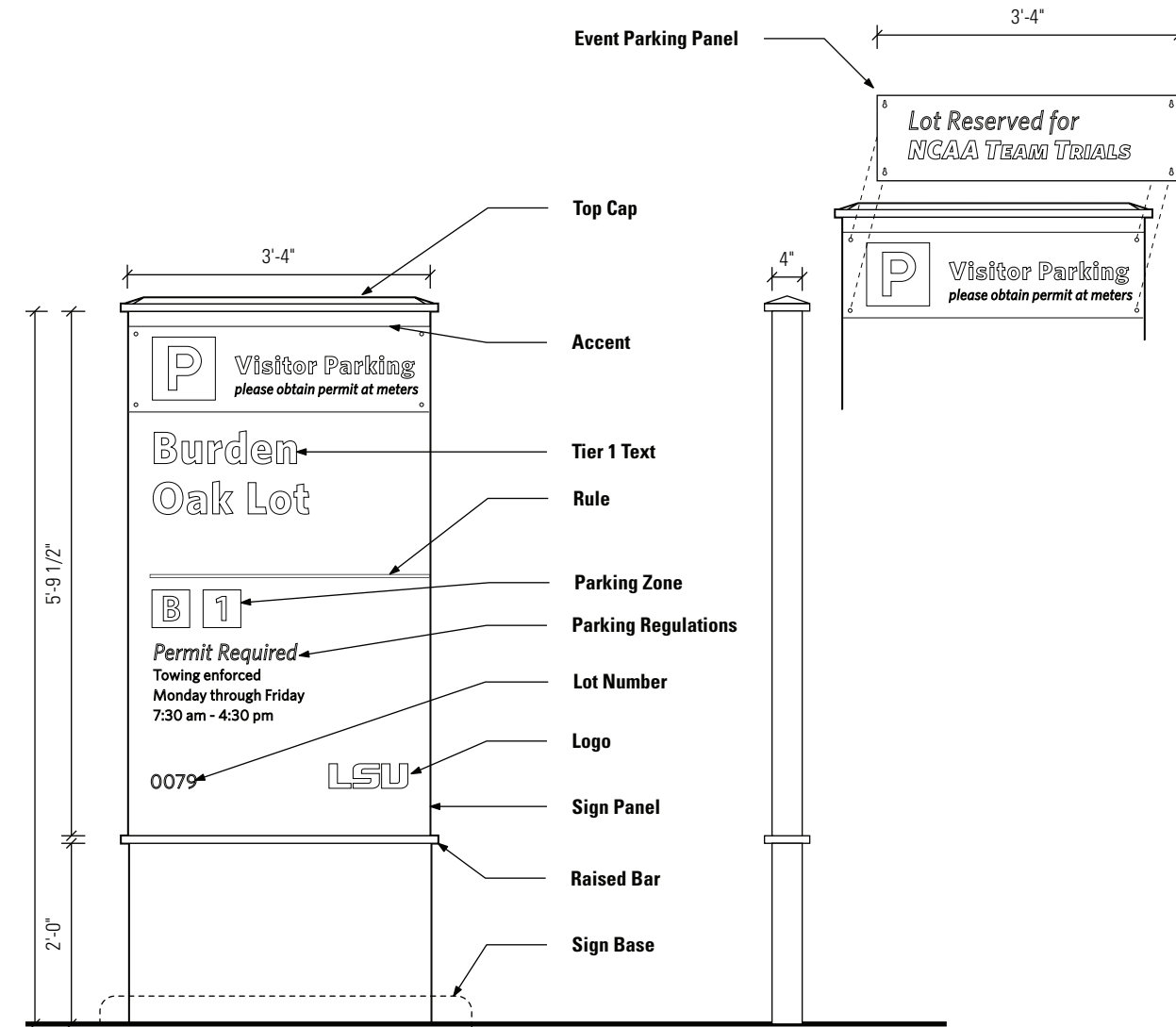

1 Elevation & Side View
Scale: 1/2" = 1' - 0" Type PK2

2 Side View
Scale: 1/2" = 1' - 0" Type PK2

PK3

parking

ON STREET

FABRICATION DETAILS

- Finial: Cast or spun aluminum or approved equal, AP3
- Parking Zone: T1, 10 1/2" sq field; 6 1/2" h., character T4, V2; backgrounds, V7-14
- Location: 1 1/8" h., V2, T5
- Headline: 1/ 1/2" h, 2 1/2" line spacing, V2, T2
- Subhead: 1" h, 1 5/8" line spacing, V2, T3
- Arrow Field: when required, 6" h., V1
- Sign Panel: Fabricated 1/8" th. aluminum panel with 3/4" radius corners inserted into post. AP1
- Sign Post: 4" square post AP3
- Sign Base: above grade (lawn) or below grade (planting bed)

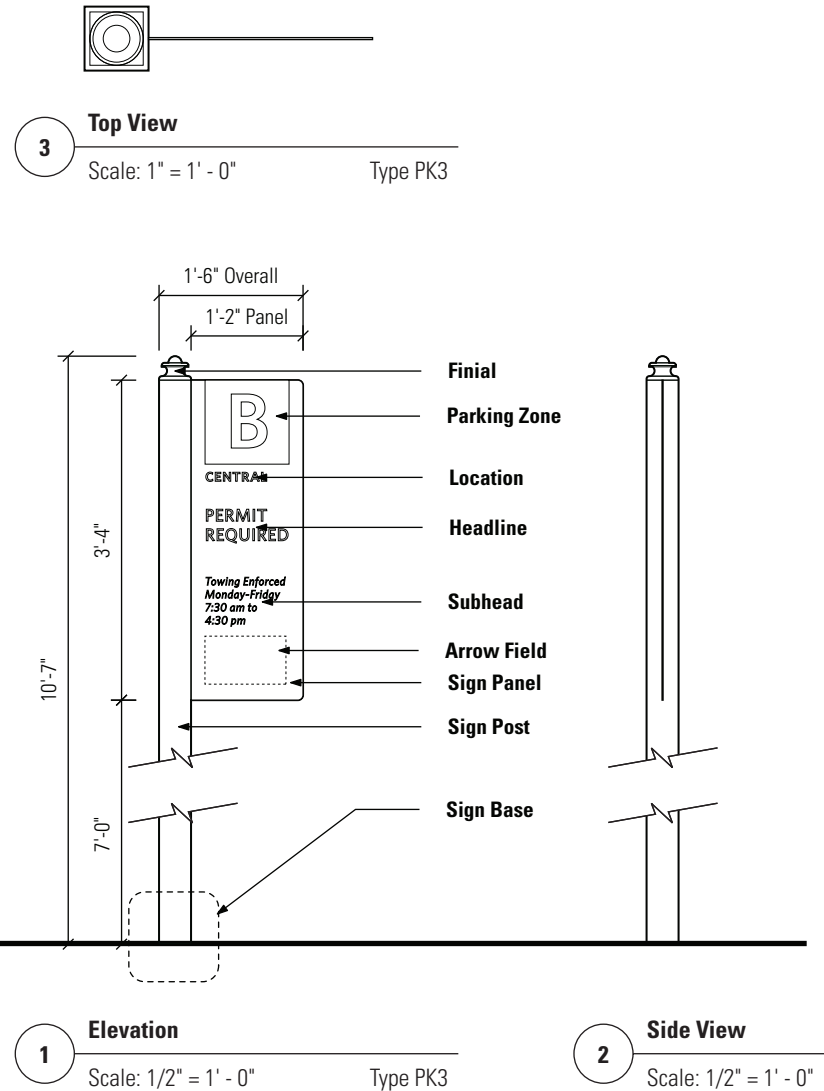

RG1

regulatory parking

FREESTANDING

FABRICATION DETAILS

- Finial: Cast or spun aluminum or approved equal, AP3
- Regulatory Symbol: 9" sq., V2, field, V6
- Headline: 1 1/4" h., V2, T6
- Subhead: 7/8" h., V2, T3
- Arrow: 5" sq., V1
- Sign Panel: 1/8" aluminum panel, AP1
- Sign Post: 4" sq, aluminum extrusion: AP3
- Sign Base: below grade, sleeve

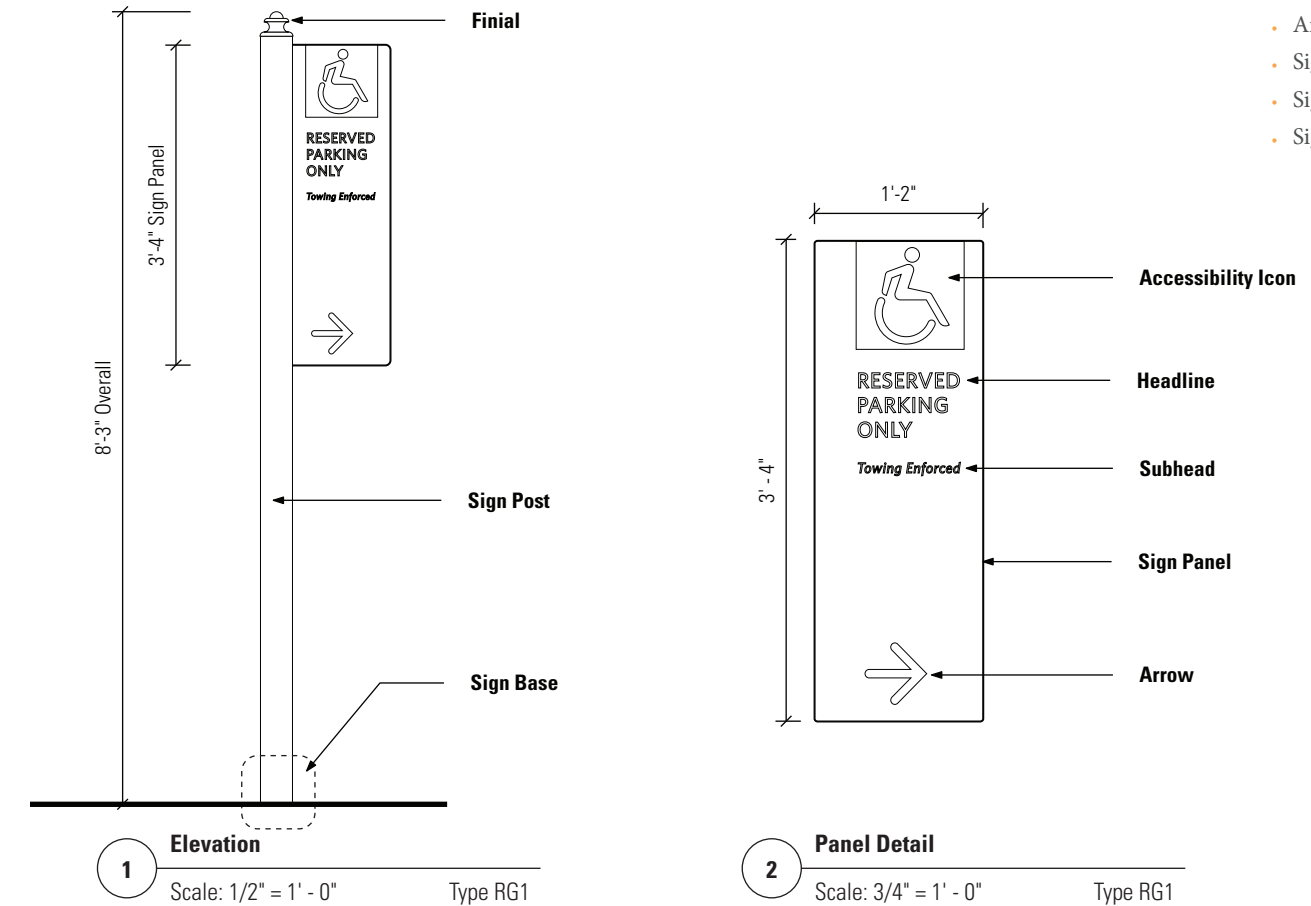

RG2

regulatory parking

POLE MOUNTED

FABRICATION DETAILS

- Regulatory Symbol: 12" dia., V2, slash, V7
- Headline: 1 3/4" h, V2, T6
- Subhead: 1 1/8" h., V2, T3
- Arrow: 6 3/4" sq., V1
- Bracket: Black "Band-it" style strap or approved equal

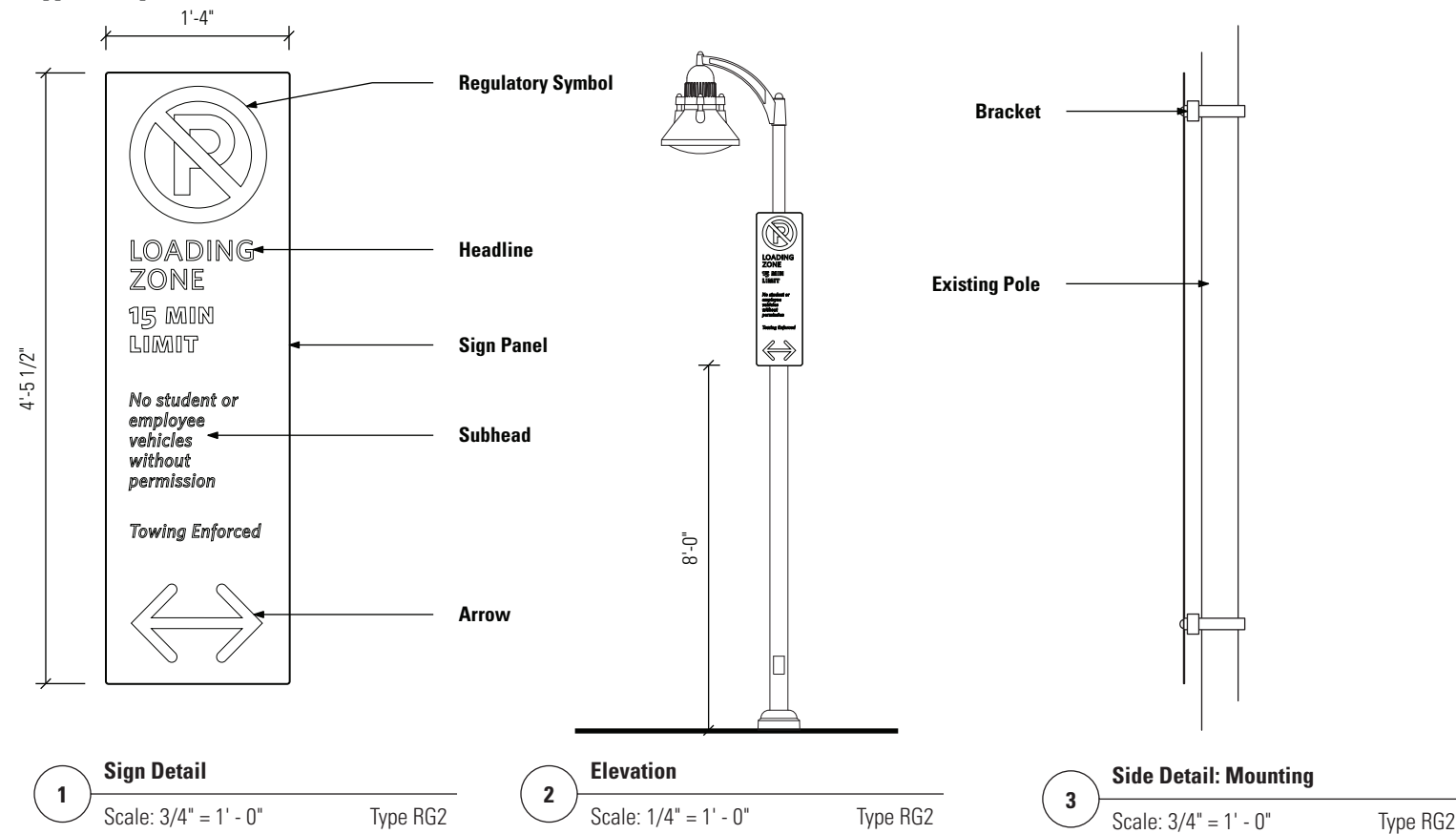

RG3

regulatory

TRAFFIC CONTROL

FABRICATION DETAILS

- Finial: Cast or spun aluminum or approved equal, AP3
- Sign Panel: .090" aluminum panel, retro-reflective graphics per MUTCD, back of signs AP3
- Sign Post: 4" sq. aluminum extrusion: AP3
- Sign Base: below grade, sleeve

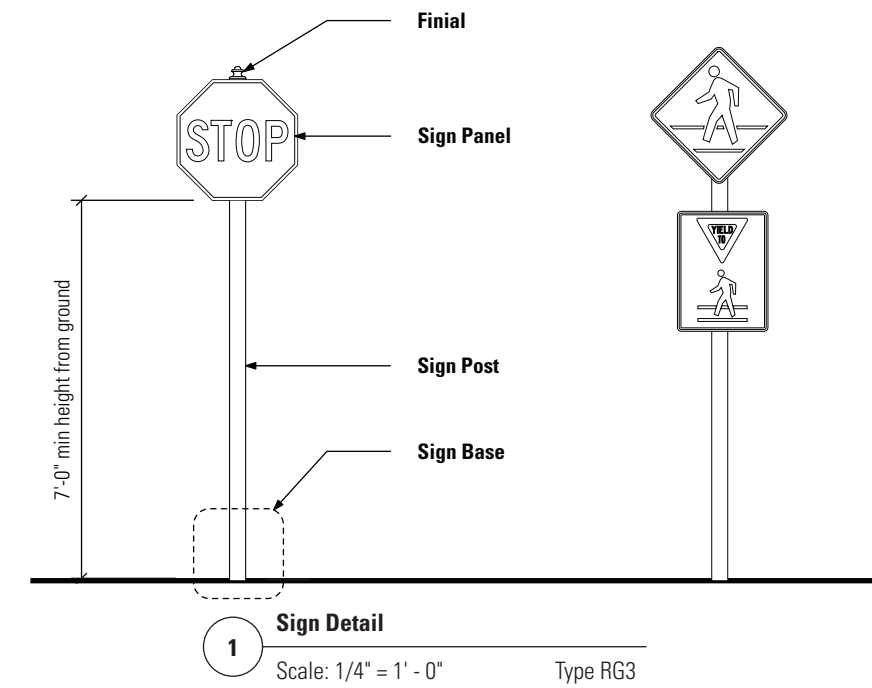

RT regional trail

FABRICATION DETAILS

- Trail Name: 1 1/4" h., T1, V2
- Symbols: V2
- Border: (varies reflective vinyl)
- Inner Field and back of sign: AP3
- Logo: 2 3/4" h., V1
- Sign Panel: router cut, .090" aluminum sheet
- Mile Marker: T2, V2
- Bracket: Black "Band-it" style strap or approved equal

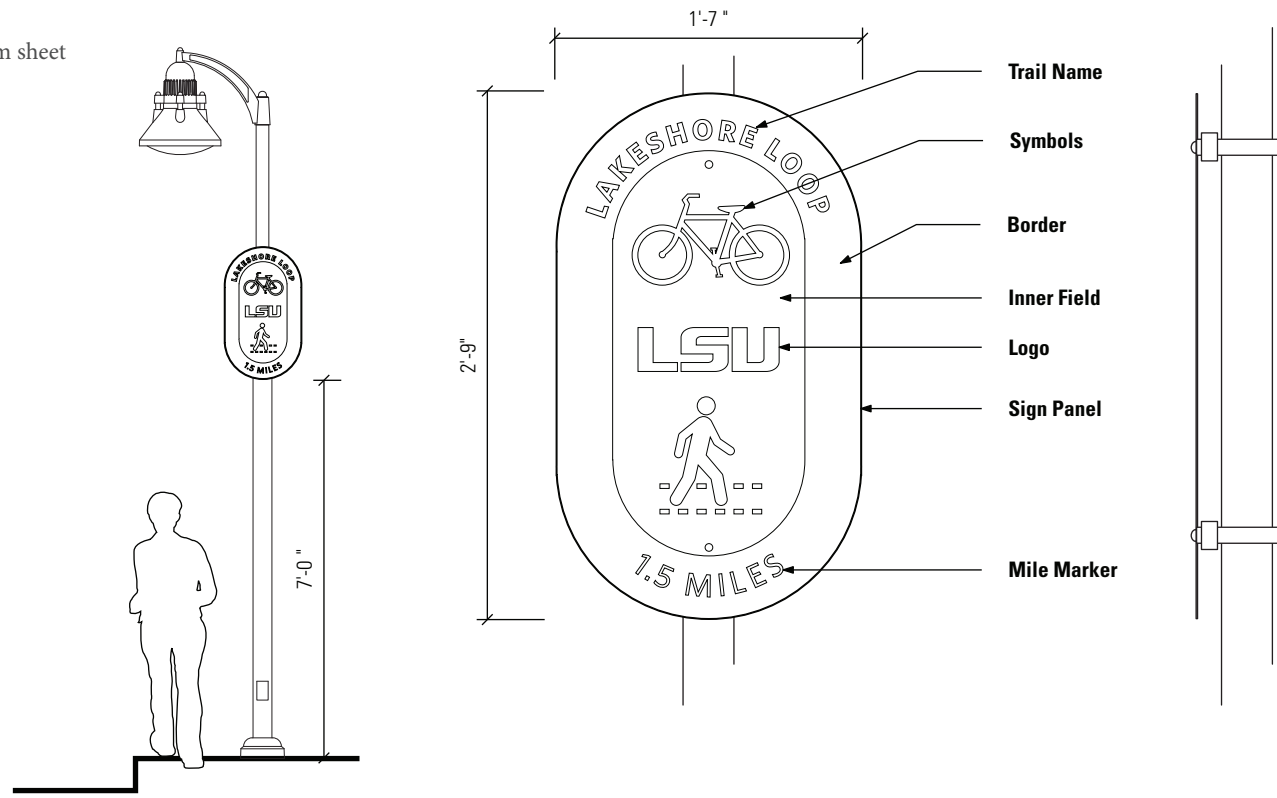

1 Elevation
Scale: 1" = 1' - 0"
Type RT

2 Sign Detail
Scale: 1" = 1' - 0"
Type RT

3 Side Detail: Mounting
Scale: 1" = 1' - 0"
Type RT

SN1 street name

MAJOR BOULEVARDS

FABRICATION DETAILS

- Accent Band: 2" h; V1
- Street Name: 8" h; V2, T1
- Street Type: 4" h; V2, T5
- Sign Panel: .060" aluminum panel PC3 (back) V9 (face)
- Bracket: Black "Band-it" style strap or approved equal

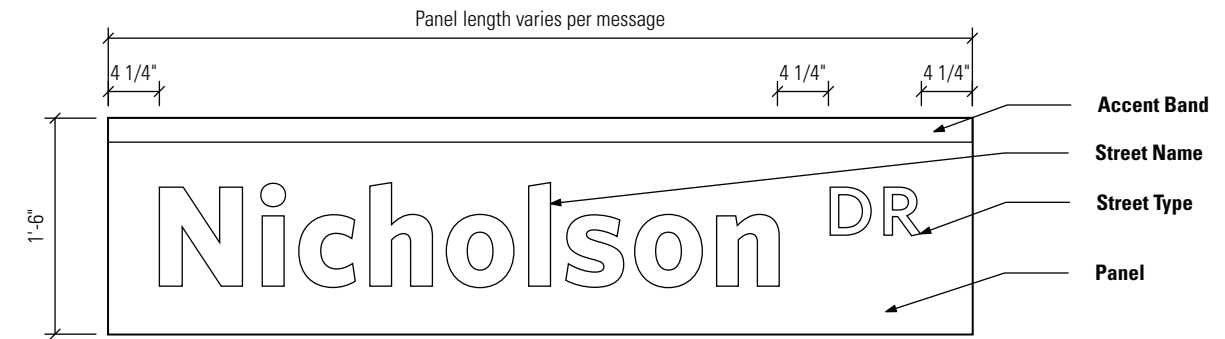

1 Sign Detail
Scale: 3/4" = 1' - 0"
Type SN1

SN2

street name

SIGNATURE CAMPUS ROADWAYS

FABRICATION DETAILS

- Finial: Cast or spun aluminum or approved equal, AP3
- Accent: 2 1/4" w., V1
- Sign Panel: .1/4" aluminum panel, V9
- Street Type: 2 3/4" h. V2, T5
- Street Name: 5" h., V2, T5
- Ornamental Bracket & Hardware: water-jet cut aluminum plate and aluminum extrusions: AP3
- Sign Post: 6" sq., aluminum extrusion: AP3
- Sign Base: break-away base, AP3

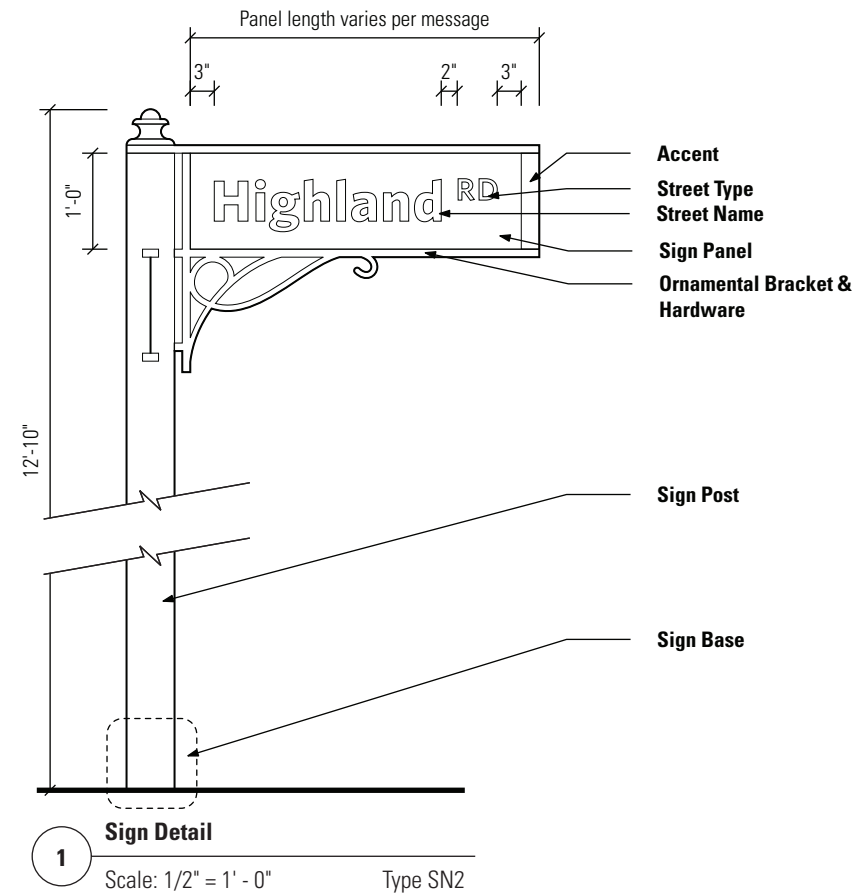

SN3

street name

SECONDARY CAMPUS ROADS

FABRICATION DETAILS

- Finial: Cast or spun aluminum or approved equal, AP3
- Accent: 2 1/4" w., V1
- Sign Panel: .1/4" aluminum panel, V9
- Street Type: 2" h. V2, T5
- Street Name: 4" h., V2, T5
- Bracket & Hardware: water-jet cut aluminum plate and aluminum extrusions: AP3
- Sign Post: 4" sq., aluminum extrusion: AP3
- Sign Base: break-away base, AP3

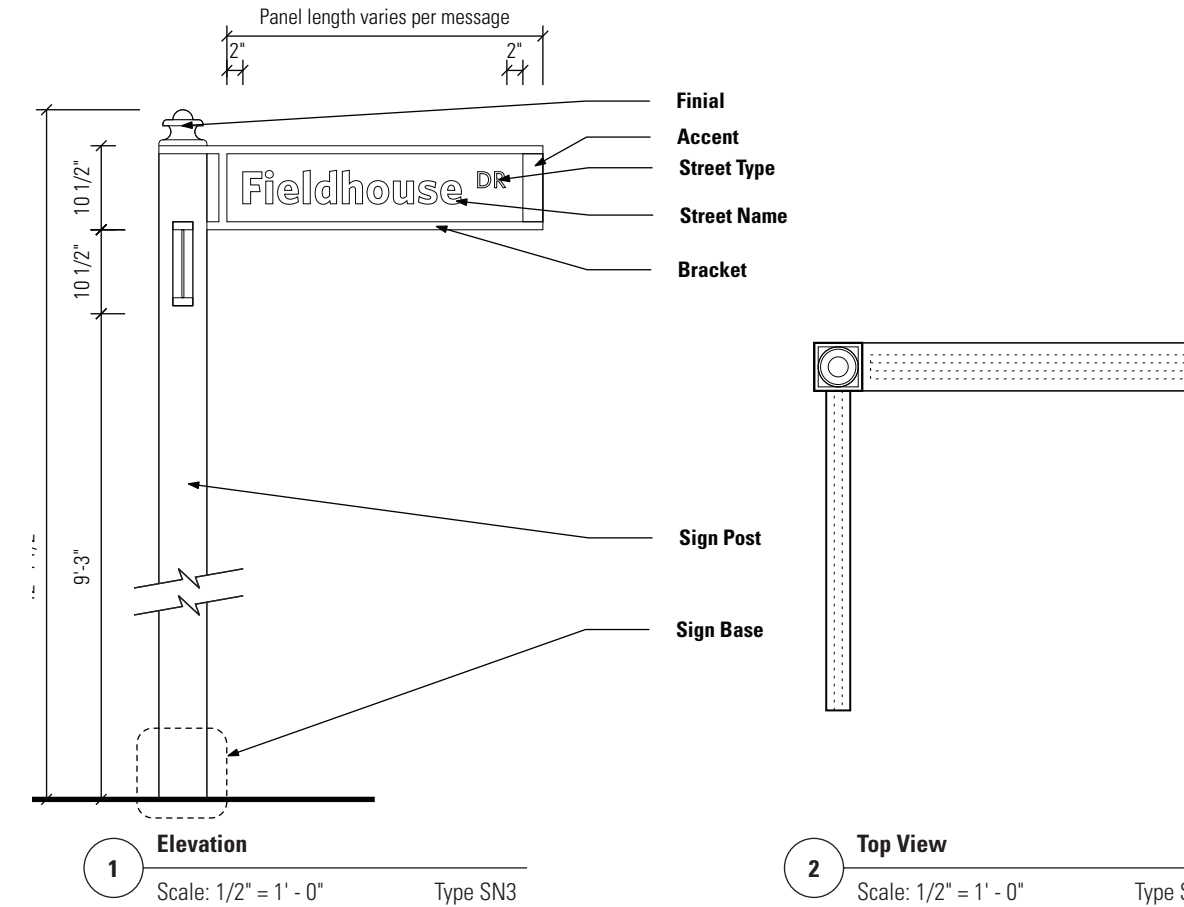

TB

regional trailblazer

OFF-CAMPUS ROADWAYS

FABRICATION DETAILS

- Sign Panel: 090" aluminum sheet with 2 1/2" radius corners, AP1
- Arrow: 11" h., V1
- Logo: 6 1/4" h., V1
- Bracket: Black "Band-it" style strap or approved equal

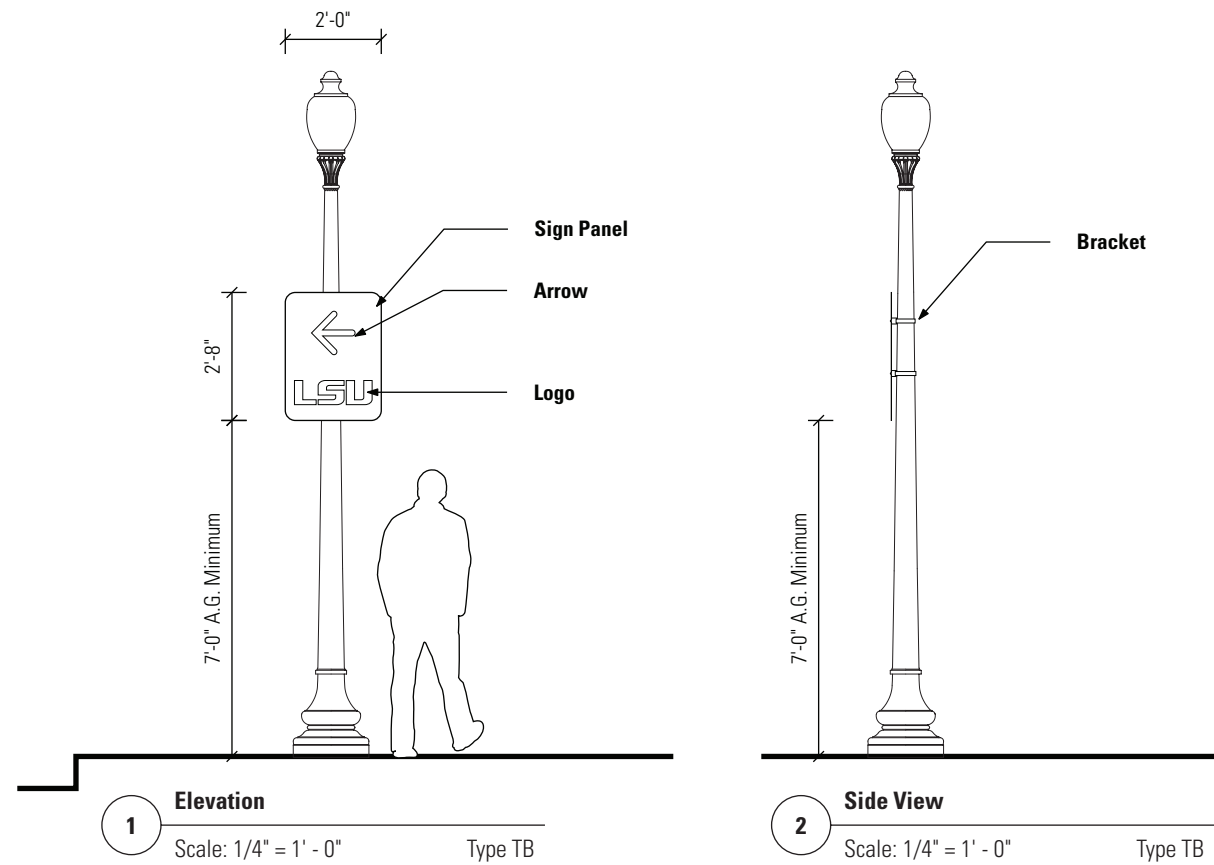



4 APPENDIX

PERFORMANCE SPECIFICATIONS

RETAIL GUIDELINES

LSU CAMPUS MAP - AFFILIATES

OUTLINE SPECIFICATIONS

PART 1 GENERAL

1.00 RELATED DOCUMENTS

- A** The BIDDING REQUIREMENTS, CONTRACT FORMS, AND CONDITIONS OF THE CONTRACT and applicable parts of DIVISION 1 - GENERAL REQUIREMENTS, as listed in the Table of Contents, shall be included in and made a part of this Section.

1.01 WORK INCLUDED

- A** Fabrication of all sign types indicated on the Drawings and enumerated in the Bid Form.
- B** Site observation to verify existing site conditions and dimensions. Site observation shall note all potential installation conflicts between sign installation locations and existing building conditions and systems.
- C** Coordination with Owner and Designer during all phases of development, fabrication, and installation.
- D** Shop drawings, layouts, samples, and prototypes for Owner and Designer approval.
- E** Full scale prototypes and mockups as required in the Specifications.
- F** Structural design and calculations when appropriate to substantiate design. It is required that the Sign Contractor include a certified engineer's review and stamp for all signage elements and footings.
- G** Review and coordinate, furnish and install all supports and footings required for the installation of all signs.
- H** Installation of all fabricated signs, including all fasteners related electrical connections.

1.03 RELATED WORK

- A** Examine Contract Documents for requirements that affect work of this Section. Other Specification Sections that directly relate to work of this Section include, but are not limited to:
 - Document 01000, GENERAL REQUIREMENTS

1.04 REFERENCES

- A** Comply with applicable requirements of the following standards. Where these standards conflict with other specified requirements, the most restrictive requirements shall govern.
 - 1** American Concrete Institute (ACI):
 - 304** Measuring, Mixing, Transporting, and Placing Concrete.
 - 305** Hot Weathering Concrete
 - 316** Construction of Concrete Pavements and Concrete Bases.
 - 2** American Society for Testing and Materials (ASTM):
 - A 53** Pipe, Steel, Black and Hot-Dipped, Zinc-Coated Welded and Seamless
 - B 209** Aluminum and Aluminum Alloy Sheet and Plate.
 - B 221** Aluminum-Alloy Extruded Bars, Rods, Wire, Shapes, and Tubes.
 - B 308** Aluminum-Alloy 6061 T6 Standard Structural Shapes Rolled or Extruded.
 - B 429** Aluminum-Alloy Extruded Structural Pipe and Tubing.
 - C 33** Concrete Aggregates
 - C 94** Ready-Mixed Concrete
 - C 143** Slump of Portland Cement Concrete
 - C 150** Portland Cement
 - C 171** Sheet Materials for Curing Concrete
 - C 494** Chemical Admixtures for Concrete
 - D 256** Impact Resistance of Plastics and Electrical Insulating Materials
 - D 638** Tensile Properties of Plastics
 - D 648** Deflection Temperature of Plastics Under Flexural Load
 - 3** American Welding Society (AWS): Aluminum Welders Certification: Provide certifications signed by Contractor, certifying that welders employed on Project comply with requirements specified under AWS D.1 and AWS D1.3.
 - 4** Louisiana State Department of Transportation (LADOT): Specifications Standard Specifications – Construction and Materials.
 - 5** Manual of Uniform Traffic Control Devices (MUTCD): Standards For Streets and Highways
- B** Codes:
 - 1** Sign Fabricator is responsible for complying with all federal, state, and city/town building codes. Any and all proposed fabrication/installation that does not

comply with these codes shall be brought to the attention of the Owner and Designer for review and resolution prior to fabrication. The Owner will be responsible for obtaining required permits to install the signs.

- 2** Sign Fabricator is responsible for complying with the Americans with Disabilities Act. ADA legislation and guidelines have been published in the Department of Justice Federal Register, July 26, 1991, 28 CFR Part 36, Title III: Public Accommodations and Commercial Facilities. Sign Fabricator is responsible for complying with all regulations subsequently issued.
- 3** Any and all proposed fabrication/installation that does not comply with ADA (including but not limited to construction, mounting, finish, contrast, and character height) shall be brought to the attention of the Owner and Designer for review and resolution prior to fabrication.

1.05 SIGN FABRICATOR QUALIFICATIONS

- A** Indicate five (5) projects which are similar in nature to the project described herein and provide the following for each:
 - 1** Name of project and its geographic location.
 - 2** Start date and completion date of project/work.
 - 3** Owner's name, addresses, telephone, and contact person.
 - 4** Brief, but thorough, description of the work including all trades involved; name(s) of responsible supervisory fabrication and installation personnel.
 - 5** Photographs of project examples listed above which represent the work of the firm.
- B** The sign fabricator must have previous experience in the fabrication and installation of a similar sign program. At least three (3) of five (5) of the projects listed above must be of similar scope and complexity to the project described herein.
- C** Firm References: Provide three (3) references from the experience list above. Provide contact name, address, telephone number, and project name and location for each reference. It is imperative that accurate contact names and phone numbers be given for the projects listed. All references should include a contact person who can comment on the firm's ability to successfully complete a project of this type. The Owner reserves the right to contact references for any projects provided as noted above, or through any other source available. Such references will be held in strict

confidence.

- D** Insurance: provide a Certificate of Insurance verifying the amount of your firm's coverage for comprehensive general liability, worker's compensation, employer's liability, and professional liability. The Owner is to be additionally insured for this coverage.
- E** Sub-contractors: All sub-contractors must be identified, and a complete description of their role relative to this contract must be included. It is highly desirable that all sub-contractors named will have prior experience working as a team. All sub-contractors must have a good working relationship with the prime contractor. If no sub-contractors are noted, it is understood that all work will be performed by the proposer's staff. The Owner reserves the right to accept or reject any sub-contractor.
- F** Minor irregularities in the bid which are immaterial or inconsequential in nature may be waived whenever it is determined by the Owner to be in their best interest. If company literature or other publications are included, they should include reference to the document name and page. Submittals containing no such citations will be considered complete and without need to refer to other documents.

1.06 SHOP DRAWINGS

- A** The drawings in this package are for design intent only. The Sign Fabricator is responsible for the proper engineering of all items. The internal structure, dimensions, and specifications for all items shall be indicated in the shop drawings. Designer will not provide electronic files of design intent drawings – it is intended that the sign fabricator produce original, CADD-generated shop drawings. In certain cases, artwork will be provided for specified patterns, logos and custom profiles.
- B** Description: Provide shop drawings for all items including:
 - 1** Complete fabrication and installation drawings for each sign type, indicate dimensions, materials, finishes, fastening, anchorage, joining, sealing, backing, utility requirements, rough-in, paving, foundation, expansion joints and adjacent related site conditions.
 - 2** Each sign type with all graphic elements.
 - 3** Accurately reproduced letter styles.
 - 4** Provide two (2) complete sets to Designer for review.
 - 5** Provide one (1) complete set to Owner for review.

1.07 PRODUCT / CATALOG DATA

- A** Submit only manufacturer's standard drawings and catalog sheets, brochures, diagrams, schedules, charts, illustrations, test results, and other standard descriptive data pages which are pertinent. Delete all non-applicable data.
 - 1** Mark-up each copy to identify pertinent materials, products, or models.
 - 2** Clearly mark-up each copy of the submittal data to identify the Section, Page Number, and Article of the Specifications to which it is referenced.
 - 3** Show dimensions and clearances required.
- B** Provide two (2) complete sets to Designer for review.
- C** Provide one (1) complete set to Owner for review.

1.08 SUBMITTALS

- A** Submit physical samples of sufficient size and quantity to illustrate materials, finishes, equipment or workmanship, and to establish standards by which completed work will be judged. Samples must represent the functional characteristics of the product or material, with integrally related parts and attachment devices, colors, and finishes.
- B** Welders Certification: Provide certifications signed by Contractor, certifying that welders employed on Project comply with requirements specified under AWS D.1 and AWS D1.3.
- C** Complete list of prototypes required shall be provided to selected Sign Fabricator. Prototypes shall become the property of Owner and may be part of completed signs as noted in Signage Schedule.
- D** First article of production-run items, both large and small, will be reviewed by the Owner and Designer before production run is commenced.
- E** Product Data: Submit manufacturer's product data of work of this Section. Provide complete product description and specifications, catalog cuts, and other descriptive data including concrete admixtures, concrete sealer, curing material.
- F** Sign Message Schedule: Designate to provide draft message schedule in MS Access. Sign Contractor to prepare final message schedule and resubmit to Designer and Owner for approval.
- G** Sign Location Plans: Designer to provide diagrammatic sign location diagrams. Based on these, Sign Contractor to prepare site-specific dimensioned sign location plans for submittal to Designer and Owner. Submittal may be supported by site

photos and notes.

- H** Field Measurements: Take all necessary field measurements before preparation of shop drawings and fabrication. Do not delay progress of the job. If field measurements are not possible prior to fabrication, allow for field cutting and fitting.
- I** Initial Selection Samples: Submit samples showing complete range of colors, textures, and finishes available for each material used.
- J** Verification Samples: Submit representative samples of the following materials for approval prior to construction. Show full color ranges and finish variations expected. Provide samples having minimum size of 144 sq. in.
 - 1** Vinyl samples, in specified type style, size and graphic, for each color and finish designated on Drawings.
 - 2** Representative masked and sprayed sample pattern in each color and finish designated on the Drawings.
 - 3** Paint color and finish sample on 1/8 in. thick aluminum, for each color and finish required.
 - 4** For each sign type, provide one (1) full size sign face layout, accompanied by scaled plots of every sign face as listed in the attached Message Schedule. Templates are not acceptable. Include character and word spacing. Outlined (pen-plotted) lettering is not acceptable.
 - 5** Plotted template or camera-ready artwork for making symbols specified; include arrow, parking symbol, etc.

1.09 PROTOTYPES & MOCK-UPS

- A** Sign Mock-ups: Prior to commencing work of this Section, provide full-size mockups of selected signs as detailed in the drawings, as directed by the Owner, at locations acceptable to the Owner. Mockups may be incorporated into finished work.
- B** Obtain Designer's acceptance of visual qualities
- C** Protect and maintain accepted mockups throughout the remainder of work of this Section to serve as criteria for acceptance of visual qualities
- D** Approved mockups may be incorporated into finished work as noted in attached Sign Schedule

1.10 SUBMITTAL REQUIREMENTS

- A** Make submittals at least ten (10) days before date that approved submittals are required.
- B** Accompany submittals with transmittal letter in duplicate, containing:
 - 1** Date
 - 2** Project title and number.
 - 3** Sign Fabricator's name and address.
 - 4** Description of data contained in submittals.
 - 5** Listing of any letters containing description of deviations from Contract Documents.
 - 6** Other pertinent data.
- C** Submittals shall include:
 - 1** Date and revision dates.
 - 2** Project title and name.
 - 3** The names of Owner, Designer, Sign Fabricator, sub-contractor, supplier, manufacturer, and separate detailer when pertinent.
 - 4** Identification of product or materials.
 - 5** Relationship of product to adjacent structure or materials.
 - 6** Clearly identified field dimensions, when known.
 - 7** Specification Section Number.
 - 8** Applicable standards, such as ASTM and others.
 - 9** A blank space, 4" x 4", for the Designer's (or consultant's) stamp.
 - 10** Identification and description of deviations from Contract Documents.
 - 11** Written request for selection of colors, patterns, and textures for materials contained in submittals. Note: Provide each and every item of finish, including color, pattern, and texture as selected or approved by Designer.
 - 12** Sign Fabricator's stamp, initialed or signed, indicating review of submittal, compliance with Contract Documents, and verification of field measurements when applicable.
- D** Provide two (2) complete sets to Designer for review.
- E** Provide one (1) complete set to Owner for review.
- F** Calculations: Provide professionally prepared calculations and certification of the performance of the work. Show how design load requirements, wind load

requirements and other performance criteria have been met. Provide calculations stamped and sealed by a professional engineer registered in the State of Louisiana.

1.11 RESUBMITTAL REQUIREMENTS

- A** Shop Drawings
 - 1** Review drawings and indicate revisions date as required, and resubmit as specified for initial submittal.
 - 2** Indicate on drawings all changes that are different than those requested by the Designer.
- B** Product data and samples: Submit new data and samples in accord with some criteria as required for first submittals.

1.12 DISTRIBUTION OF SUBMITTALS AFTER REVIEW

- A** Distribute copies of shop drawings and product data which carry Owner's approval stamp to:
 - 1** Sign Fabricator's file, job site file, and product record documents file.
 - 2** Sub-contractors, suppliers, and sign fabricators as appropriate.
 - 3** Other prime contractors.
- B** Distribute samples as directed by Owner.

1.13 SIGN FABRICATOR'S RESPONSIBILITIES

- A** Sign fabricator is responsible for providing any necessary computer program conversion, font, computer program, or equipment purchases; or other provisions in order to coordinate exactly with the Designer's drawings and other submissions.
- B** Review shop drawings, product data, and samples prior to submittal to Owner.
- C** Verify field measurements, field construction criteria, catalog numbers, and similar data.
- D** Coordinate each submittal with work of the project and with the Owner's Contract Documents.
- E** Sign Fabricator's responsibility for errors and omissions in submittals or in deviations from the requirements of the Contract Documents is not relieved by the Owner's review of submittals.

- F** Notify Owner and Designer in writing of deviations from requirements of the Contract Documents at the time of submittals.
 - 1** A "deviation" shall be construed to mean any change to the sequence indicated on Drawings or specifications.
 - 2** A "deviation" is not intended to allow substitutions or product options.
 - 3** In addition to notifying Owner in writing of deviations, clearly indicate deviations on shop drawings.
- G** Do not begin work that requires submittals until submittals have been returned with Owner's (or consultant's) stamp and initials indicating review and approval.
- H** After Owner's review, distribute copies of approved drawings, data, and submittals.

1.14 OWNER'S RESPONSIBILITIES

- A** Review submittals with reasonable promptness on basis of design concept of project and information contained in Contract Documents.
 - 1** The scope of the Owner's review is to check for general conformance with the design concept of the project and general compliance with Contract Documents only. No responsibility is assumed by Owner for accuracy of dimensions, details, quantities, or procedures shown on shop drawings or submittals.
 - 2** Omission in shop drawings of items, materials, or processes indicated in Contract Drawings or Specifications, or otherwise required for proper execution and completion of work, does not relieve the Sign fabricator from responsibility for providing such items, materials, or processes. Sign fabricator is responsible for accuracy, dimensions, quantities, strength of connection, coordination with various trades, and conformance to project requirements and all applicable codes.
 - 3** Approval of a separate or specified item does not necessarily constitute approval of an assembly in which item functions.
- B** Affix stamp and initials or signature acknowledging review of submittal as follows:
 - 1** Approved.
 - 2** Approved with notations, resubmittal not required.
 - 3** Not approved. Resubmittal required.
- C** Return submittals to Designer for distribution.

1.15 DESIGNER'S RESPONSIBILITIES

- A** Review submittals with reasonable promptness as they relate to design concept of project and information contained in Contract Documents.
 - 1** The scope of the Designer's review is to check for general conformance with the design concept of the project and general compliance with Contract Documents only. No responsibility is assumed by Designer for accuracy of dimensions, details, quantities, or procedures shown on shop drawings or submittals.
 - 2** Omission in shop drawings of items, materials, or processes indicated in Contract Drawings or Specifications, or otherwise required for proper execution and completion of work, does not relieve the Sign fabricator from responsibility for providing such items, materials, or processes. Sign fabricator is responsible for accuracy, dimensions, quantities, strength of connection, coordination with various trades, and conformance to project requirements and all applicable codes.
 - 3** Approval of a separate or specified item does not necessarily constitute approval of an assembly in which item functions.
- B** Refer to Section 01000, GENERAL REQUIREMENTS for Architect's Action on Submittals.
- C** Selected artwork files may be provided to the Sign Fabricator, as Adobe Illustrator files (CS, PC Platform).
- D** Return of submittals to sign fabricator with all comments.

1.16 MAINTENANCE MANUALS

- A** Provide three (3) up-to-date copies of all shop drawings, product data, and other information described in this Section.
 - 1** Make required submittals not later than six (6) weeks prior to scheduled completion of project.
 - 2** Submittals shall be made by permanent reproduction copy equipment from typewritten or typeset originals.
 - 3** Pre-punch 8 1/2 x 11" sheets for standard three ring binders.
 - 4** Submit larger sheets in rolled and protected packages.
- B** Submittal format: Provide each of the following items, as applicable, for each required item.

- 1 Manufacturer's data: provide catalog data sheets, specifications, name plate data, and parts list.
- 2 Extra parts: Provide a listing of extra stock or parts furnished as part of the Contract.
- 3 Warranties: Provide specific manufacturer's warranty. List each component covered with day and date warranty begins, date of expiration, and name, address, and telephone number of person to contact regarding problems during warranty period.
- 4 Provide names, addresses, and telephone number of sign fabricator, its subcontractors, suppliers, installers, and authorized service and part suppliers.

Format as follows:

4a Sign Fabricator:

Address:

Telephone Number

Fax Number:

Person to Contact:

4b Sub-Contractor:

Address:

Telephone Number:

Fax Number:

Person to Contact:

4c Installer:

Address:

Telephone Number:

Fax Number:

Person to Contact:

4d Local Representative:

Address:

Telephone Number:

Fax Number:

Person to Contact:

1.17 WARRANTY

- A** Warrant all work against failure because of faulty materials, workmanship, assembly and installation, for a period of five (5) years from date of substantial completion.
- B** Fading, cracking, warping, peeling, delaminating, rusting, corroding, and structural failure, including distortion by whatever cause, shall be construed to mean failure because of faulty materials and workmanship.
- C** Failures during the warranty period shall be repaired or replaced to the satisfaction of the Owner and Designer.

1.18 MAINTENANCE MATERIALS

- A** Touch-up paint: Provide Owner with one quart can of touch-up paint of each type and color used in the work.

1.19 QUALITY ASSURANCE

- A** Source: For each material type required for the work of this Section, provide primary materials which are the product of one manufacturer. Provide secondary or accessory materials which are acceptable to the manufacturers of primary materials.
- B** Installer: A firm with a minimum of three years experience in type of work required by this Section and which is acceptable to manufacturers of primary materials.
 - 1 If installer is different company than sign manufacturer, notify Designer in advance providing installer's name, address, telephone number, and name of contact person.
- C** All work and material shall be in accordance with all applicable codes and standards and shall be acceptable to all authorities having jurisdiction. Work shall meet or exceed the requirements of the Louisiana State Building Code.
- D** Design Criteria: The Drawings indicate size, profiles, and dimensional requirements of signs and graphics, and are based on the specific type and model indicated. Signs by other manufacturers may be considered provided the deviations in dimensions and profiles are minor and do not, in the opinion of the Designer, change the design concept.
 - 1 Fonts: Sign Contractor must purchase specified original font software from font suppliers; Designer will not supply font software or digital copies of fonts. Conversions, translations, or "close matches" are not acceptable.

- 2 Computer Capabilities: Manufacturer must have capability to process digital files prepared on Windows PC platform. Translations to alternate sign cutting platforms must be approved by the Designer.
- 3 Software: Manufacturer must possess PC-based software versions of Adobe Illustrator and Microsoft Access. Conversions to other software or platforms must be approved by the Designer.

1.20 PERFORMANCE REQUIREMENTS

- A** Design: Engineer and design signage units to withstand stresses induced by wind loads, live loads, dead loads, temperature, shrinkage, fabrication, handling and erection in accordance with applicable codes. Furnish engineer's certificate stating that sign design meets or exceeds requirements of Contract Documents.

1.21 DELIVERY, STORAGE AND HANDLING

- A** Deliver materials and products unopened. Store and handle in strict compliance with manufacturer's instructions and recommendations. Store under cover and protect from weather damage.
- B** Sequence deliveries to avoid delays, but minimize on-site storage. Coordinate work and storage requirements with the Building Contractor, subject to approval by the Owner and Designer.

PART 2 PRODUCTS

2.01 ALUMINUM

- A** Aluminum, General: Provide alloy and temper recommended by aluminum producer and finisher for type of use and finish indicated, and with strength and durability properties for each aluminum form required not less than that of alloy and temper designated below.
- B** Yield strength for Alloy 6063-T5/T52 is 15 to 16 ksi (105 to 110 MPa).
- C** Extruded Bars and Shapes: ASTM B 221 (ASTM B 221M), Alloy 6063-T5/T52.
- D** Drawn Seamless Tubing: ASTM B 210 (ASTM B 210M) or ASTM B 483/B 483M, Alloy 6063-T832.
- E** Plate and Sheet: ASTM B 209 (ASTM B 209M), Alloy 6061-T6.
- F** Castings: ASTM B 26/B 26M, Alloy A356.0-T6.

2.02 STEEL

- A** General: If the Contractor employs steel for structural design, steel shall be as follows. Provide manufacturer's standard extrusions, sections, sheet, and plate, of alloy and temper recommended by steel manufacturer or finisher for type, use, and finish indicated, but not less than strength and durability properties specified below.
- B** Steel Tubing: ASTM A500 or A 501, hot or cold rolled.

2.03 VINYL

- A** Applied Reflective Vinyl Graphics: Pressure sensitive vinyl graphics shall be Scotchlite Reflective Sheeting Series 3200, Engineer Grade, enclosed lens reflective sheeting, manufactured by 3M, or approved equal. Color shall be as indicated in the Drawings.
- B** Applied Non-reflective Vinyl Graphics: Pressure sensitive vinyl graphics shall be Scotchcal, 0.4 mil applied pressure sensitive vinyl, manufactured by 3M, or approved equal. Color shall be as indicated in the Drawings.

2.04 MISCELLANEOUS MATERIALS

- A** Fasteners: Unless otherwise indicated, use concealed fasteners in all work of this Section. Fabricate fasteners from metals that are non-corrosive (aluminum or non-

magnetic stainless steel) to sign surface materials and mounting substrates.

1. Exposed fasteners shall be roundhead and vandal-resistant.
2. Spacers and washers shall be neoprene or EPDM.

- B** Anchors and Inserts: Provide non-ferrous metal or hot-dip galvanized anchors and inserts for exterior installations. Provide toothed steel or lead expansion bolt devices for drilled-in place anchors. Furnish inserts to other trades when required to be cast into concrete.
- C** Permanent Bond Adhesive: Provide structural adhesive suitable for bonding a variety of dissimilar industrial surfaces over a wide temperature range, similar to “PR-943”, manufactured by Products Research and Chemical Corporation, Gloucester City, NJ 08030, or approved equal.
- D** Acrylic Foam Tape: Use VHB Tape, 4929 (black) as manufactured by 3M.
- E** Grout for Exterior Applications: Provide Factory-packaged, non-shrink, non-staining, hydraulic controlled expansion epoxy-type, or cement formulation for mixing with water at project site. Provide formulation that is resistant to erosion from water exposure without need for protection by a sealer or waterproof coating. Provide Super Por-Rok, Erosion-Resistant Anchoring Cement, manufactured by Minwax Construction Products Division, or equal as approved by Architect.

2.05 FINISHES: PAINT

- A** Acrylic Polyurethane Finish: For surfaces indicated in the Drawings to be painted with acrylic polyurethane, provide Matthews Acrylic Polyurethane, satin finish paint system consisting of a pigmented component, a catalyst and a flattening agent, manufactured by Matthews Paint Company, Wheeling, IL 60090, or approved equal. Paint shall contain three ultraviolet inhibitors to prevent fading.
- B** Color selection: Exterior aluminum sign, post, and support surfaces indicated to be painted shall be in colors and finishes indicated on the Drawings
 1. Compile and maintain a listing of all colors with the factory batch number and formulation code for all paints and coatings. At the date of substantial completion, submit the list to the Owner for future maintenance reference.
 2. Provide finish coat color matching accepted color samples within industry tolerances and identified as specified. More than one color will be required.
- D** Gloss shall be satin.

- E** The term “paint” refers to those materials that require a finished surface as recommended by the approved materials manufacturer. “Paint” includes preparation, priming/sealing, and intermediate and finish coats as applicable.

- F** Sample finishes: Refer to Previous Section.

- G** Application and Finish:

1. Coatings shall be applied by an applicator having facilities, equipment, and experience required to apply the finish to the manufacturer’s specifications. All substrates shall be cleansed of any foreign substance such as oil, grease, dirt, etc. Typical finish shall consist of:
 - 1a An acid-wash prime coat applied per manufacturer’s specifications when using raw metal as a substrate.
 - 1b Primer/filler seal coat, properly applied to all substrates per manufacturer’s specifications including dry film thickness.
 - 1c Primer/filler coat sanded smooth before top coating and coated with a minimum of two applications of acrylic polyurethanes in colors indicated on the design drawings. Top coating shall be applied per manufacturer’s recommendations to a minimum total dry film thickness of 2.0 mil.
2. Coating Performance Criteria: (In addition to above)
 - 2a Dry film thickness: Within minus 5% to plus 25% of the specified thickness
 - 2b Abrasion resistance: ASTM D968 coefficient of abrasion 65 minimum.
 - 2c Pencil hardness: 2H minimum.
 - 2d Salt spray: ASTM B-117 withstanding 3500 hours, 100% salt fog at 95 degrees F and retaining adhesion, corrosion resistance, color, and gloss with no more than minimal blisters no larger than No. 8 (ASTM D-714), and no more than 1/16” creep or loss of adhesion from scribed line.
 - 2e Humidity test: ASTM D-2247 withstanding 3500 hours 100% relative humidity at 95 to 100 degrees F and retaining adhesion, corrosion resistance, color, and gloss with no more than minimal blisters no larger than No. 8 (ASTM D-714), and no more than 1/16” creep or loss of adhesion from scribed line.
 - 2f Gloss: ASTM D523, +/-5%, using a 60 degree glossmeter, of the gloss level selected by the Designer.

- 2g** Adhesion: No removal of any finish after 1/16” crosshatching to base metal, impacting to the point of metal rupture, and subjected to application and quick removal of cellophane tape.

2.06 TRAFFIC SIGNS

- A** All regulatory and traffic control signs shall be made of 18 gauge hot-dip galvanized steel, bonderized after fabrication; or .080 flat aluminum alloy, Type A, as specified under LADOT Specifications, bonderized or anodized.
- B** Size, background color, border and legend size and color shall be as specified in the Manual of Uniform Traffic Control Devices (MUTCD) and as indicated on the Drawings.

2.07 UNEXPOSED CONCRETE

- A** Cylindrical Forms: Sonotube Fibre Forms, wax-impregnated strippable forms manufactured by Sonoco Products Company, General Products Division or approved equal, or ABS or PVC plastic reusable forms.
- B** Concrete shall be air-entrained type, conforming to ASTM C 94.
- C** Unless otherwise indicated on the Drawings, minimum 28 day compressive strength shall be 3,000 psi.
- D** Concrete slump shall be no less than 2 in. no greater than 4 in., determined in accordance with ASTM C 143.
- E** Cement shall be Portland cement, conforming to ASTM C 150, Type I or II.
- F** Aggregates shall conform to ASTM C 33.
- G** Concrete shall contain a water reducing agent to minimize cement and water content of the concrete mix at the specified slump. Water reducing agent shall conform to ASTM C 494.
- H** No calcium chloride or admixtures containing calcium chloride shall be added to the concrete. No admixtures other than those specified shall be used in the concrete without the specific written permission of the Designer in each case.

PART 3 EXECUTION

3.01 GENERAL

- A** The Owner will field mark the location of all signs prior to installation. Contractor shall review all locations with the Owner before starting installation.
- B** Locate sign units and accessories where shown and scheduled. Use mounting methods indicated.
- C** Cutting, Fitting, and Placement: Perform cutting, drilling, and fitting required for installation of work of this Section.
- D** Erect work square, plumb and true, accurately fitted, and with tight joints and intersections. All anchors, inserts and other members to be set in concrete shall be furnished loose by this trade to be built-into concrete by that trade. Avoid field cutting or drilling to greatest extent possible.
- E** Fit exposed connections accurately together to form hairline joints, except where invisible joints are indicated. Shop weld connections, except when work cannot be shop welded due to shipping size or galvanizing limitations.
- F** Fastening to In-Place Construction: Provide anchorage devices and fasteners necessary for securing work of this Section to in-place construction. Include threaded fasteners for concrete and masonry inserts, toggle bolts, through bolts, lag bolts, wood screws, and other connectors required.
- G** Field Welding: Comply with AWS Code for procedures of manual welding, appearance and quality of welds, and correction methods for defective welds.
- H** Where members other than expansion bolts or inserts are fastened into rock or concrete set such members in proprietary-type non-shrink epoxy grout manufactured specifically for such purpose. Use grouts strictly in accordance with manufacturer’s directions. Form to receive members with galvanized metal sleeves, or other approved method to provide at least 1/2 in. clearance around entire perimeter.
- I** Electrolytic Isolation: Where dissimilar metals are to come into contact with one another, or in contact with concrete, isolate by application of a heavy coating of bituminous paint on contact surfaces in addition to shop coat specified above. Do not permit the bituminous paint in any way to remain on surfaces to be exposed or to receive sealant.

3.02 WORKMANSHIP

- A** It is intended that the workmanship be of the highest quality obtainable by the respective trades and crafts experienced in the fabrication of signs, and that all work be done by journeymen, or by tradesmen under the direct supervision of journeymen.
 - 1** “Journeymen” shall be interpreted to mean those craftspeople having the qualifications and experience to meet the requirements described in the Job Classification and Description for the Electric Sign Industry, as developed by the NESAs/Tri-Trades Committee.

3.03 FABRICATION

- A** General: Fabricate work of this Section in conformance with requirements indicated for materials, thicknesses, finishes, colors, designs, shapes, and sizes.
- B** All Signs: Fabricate flat and curved signs using metals and shapes of sufficient thickness, with reinforcing when necessary, to produce sufficient flatness, free of “oil canning”, and to impart sufficient strength for size, design, and application indicated. Produce smooth, even level sign surfaces.
 - 1** Fabricate posts, brackets, and fittings from extruded aluminum to suit sign panel construction and mounting conditions indicated; all seams welded and ground smooth prior to painting.
 - 2** Colors: Where applied graphics require color selection, provide colors as indicated and as approved by Designer.
 - 3** Graphic Content and Style: Provide graphics for signs in letter style, size, spacing, and arrangement indicated.
 - 4** Where applied vinyl copy is indicated, provide die-cut copy characters from vinyl film with pressure sensitive adhesive backing. Apply copy to exposed face of sign panel.
 - 5** Fabricate framing with reinforced corners, fabricated to a hairline fit.
 - 6** All signs to be properly vented top and bottom to minimize water penetration and prevent moisture buildup or condensation on transparent surfaces.
 - 7** Any openings or vents must have fine mesh screen barrier to prevent insect or animal intrusion and nesting.
- C** Allow for thermal movement resulting from a maximum ambient temperature change (range) of 100° F. (55.5° C.). Design, fabricate, and install the sign assembly to prevent buckling, opening up of joints, and overstressing of welds and fasteners.

- D** Welded Connections: Comply with AWS for recommended practices in shop welding. Provide welds behind finished surfaces without distortion or discoloration of the exposed side. Clean exposed welded surfaces of welding flux and dress on all exposed and contact surfaces.
- E** Mill joints to a tight, hairline fit. Form joints exposed to the weather to exclude water penetration.
- F** It is intended that all finished work be of the highest quality to pass eye-level examination and scrutiny by the Owner.
 - 1** Construct all work to eliminate burrs, dents, cutting edges, and sharp corners.
 - 2** Finish welds on exposed surfaces to be imperceptible in the finished work.
 - 3** Finish all surfaces smooth except as indicated or directed otherwise.
 - 4** Surfaces which are intended to be flat shall be without dents, bulges, oil canning, gaps, or other physical deformities.
 - 5** Surfaces which are intended to be curved shall be smoothly free-flowing to required shapes.
 - 6** All exterior hardware and fasteners shall be non-corrosive, non-rusting aluminum or stainless steel as noted on Fabricator’s Shop Drawings.
 - 7** Conceal all fasteners except as indicated or directed otherwise.
 - 8** Make access panels tight-fitting, lightproof, and flush to adjacent surfaces.
 - 9** Conceal all identification labels and U.L. labels to conform to U.L. Codes.
 - 10** Carefully follow manufacturer’s recommended fabricating procedures regarding expansion/contraction, fastening, and restraining of all materials.
 - 11** Exercise care to assure that painted, polished, and plated surfaces are unblemished in the finished work.
 - 12** Isolate dissimilar materials. Exercise particular care to isolate nonferrous metals from ferrous metals.
 - 13** All illumination shall be even and without hot spots.

3.04 EXCAVATION AND SUBGRADE PREPARATION

- A** Provide excavation work as required to install signage and footings as indicated. Contractor shall notify the Owner and LA One-Call contractor shall obtain Evacuation Permit issued by LSU Faculty Development prior to the commencement of excavation.

- B** As excavation approaches underground utilities and structures, excavation shall be done by hand tools. Such manual excavation is incidental to normal excavation and no special payment will be made.
- C** Excavation shall include satisfactory on-site disposal of excavated material. Coordinate on site disposal with the Owner.
 - 1** Excavation material, other than topsoil, which is not required for or is unsuitable for backfill or fill materials, shall be legally disposed of off-site.
- D** Two signs (14 and 15) are in areas of shallow bedrock (hard limestone). Contractor shall price these post holes as rock drilling with posts anchored in rock.

3.05 UNEXPOSED CONCRETE

- A** Before placing concrete, forms and space to be occupied by concrete shall be thoroughly cleaned, and reinforcing steel and embedded metal that may be required shall be free from dirt, oil, mill scale, loose rust, paint, and other material which might tend to reduce bond.
- B** Concrete which has set or partially set before placing shall not be employed. Retempering of concrete will not be permitted.
- C** Concrete shall be thoroughly spaded and tamped to secure a solid and homogeneous mass, thoroughly worked around reinforcement and into corners of forms.
- D** Concrete shall be kept continuously damp from time of placement until end of specified curing period. Between finishing operations surface shall be protected from rapid drying by a covering of waterproofing paper. Surface shall be damp when the covering is placed over it.
- E** The tops of all concrete foundations shall be set at ½ inch above surrounding grade to allow for future mowing and weed control around the sign posts, and to minimize the visibility of the concrete foundation. Tops of concrete foundations shall not project more than ½ inch above grade, nor should they be sunk below grade which would allow soil to be backfilled around the post and grass and weeds to grow around the post.

3.06 FINISH

- A** Paint finish shall be applied in strict compliance with coating system manufacturer’s instructions and recommendations for surface preparation, mil thickness, curing and

other requirements.

3.07 INSPECTION

- A** The Installer shall examine substrates, supports, and conditions detrimental to the proper completion of work. Do not proceed with work until unsatisfactory conditions are corrected. Beginning of sign installation will be construed as installer accepting substrates and conditions.

3.08 TRANSPORTATION OF WORK

- A** Transport, deliver, handle, and store materials and equipment at the job site in such a manner as to prevent damage to both the site and the signs, including damage to finishes and damage which might result from intrusions of foreign matter or moisture from any source.
- B** Packaging:
 - 1** Maintain packaged materials in manufacturer’s original container with seals unbroken and labels intact until they are incorporated into the Work.
 - 2** Packaged material shall bear the name of the manufacturer and the product, including brand name, color, stock number, and all other complete identifying information.
 - 3** Packages showing indications of damage that may affect conditions of content are not acceptable.
- C** Promptly remove all damaged or otherwise unsuitable materials and equipment from the job site.
- D** Storing:
 - 1** Store all materials and equipment in accord with manufacturer’s instructions. Store above grade and properly protected from weather and construction activities.

3.09 SIGN INSTALLATION

- A** General Installation Requirements: Strictly comply with manufacturer’s instructions and recommendations, except where more restrictive requirements are specified in this section.
- B** Exterior signs shall be installed in various stages in response to the overall Project construction schedule. Install signage in strict accordance with approved phasing plan to be worked out with the Owner.

- C** Installation: Install units plumb, level, in alignment and plane without warp or rack. Anchor securely in place.
- D** Verify the exact location with the Owner and Designer for all signs which are not precisely dimensioned on the Drawings.
- E** Sign installation work shall be under the direct supervision of a journeyman sign erector.
- F** Securely anchor work in proper location using anchors, fasteners, or other methods approved on shop and erection drawings. All anchors/fasteners shall be appropriate for the anchorage condition.

3.10 TOLERANCES

- A** The following allowable installed tolerances are allowable variations from locations and dimensions indicated by the Contract Documents. Do not add these tolerances to any allowable tolerances indicated for other work.
 - 1** Allowable Variation from True Plumb: + 1/8 in. in 20 ft. - 0 in.
 - 2** Allowable Variation from True Line: + 1/8 in. in 20 ft. - 0 in.
 - 3** Allowable Variation from True Level: + 1/16 in. in 20 ft. - 0 in.

3.11 ADJUSTING, CLEANING, TOUCH-UP, AND PROTECTION

- A** Clean exposed surfaces using manufacturer’s printed instructions recommending materials and methods to be used. Remove and replace work which cannot be successfully cleaned.
- B** Touch-up damaged coatings and finishes. Eliminate visible evidence of repair.
- C** Provide temporary protection during the course of work, and immediately after completion to ensure work is not damaged or deteriorated in any way at time of final acceptance. Remove temporary protections and re-clean as necessary immediately prior to final acceptance.
- D** Clean-up work area after installation has been completed.

3.12 PUNCH LIST

- A** When Sign Fabricator considers the work has reached final completion (that is, when less than one percent of the Contract remains to be completed), submit written notice, together with a written list of items to be completed or corrected.
- B** The Owner will inspect the status of completion and prepare a “Punch List” setting

forth in detail any items on the Sign Fabricator’s list and additional items found unacceptable. When the Punch List is complete, the Owner will arrange a meeting with the Sign Fabricator to identify and explain all items and respond to questions regarding the work which must be done before final acceptance.

- C** Sign Fabricator shall correct Punch List items within an Owner-approved time frame established when the punch list is made. The time frame for completion of the Punch List items shall not exceed the completion date of the Contract. The Contract shall not be considered complete until Punch List items are completed.

END OF SECTION

RETAIL SIGNAGE GUIDELINES

INTENT AND PURPOSE

These guidelines are intended to facilitate the commercial success of retail tenants and ensure signage solutions that will contribute to a vibrant pedestrian environment. Tenants are encouraged to create exciting and unique designs through the use of innovative materials and fabrication techniques. LSU will reserve the right to require modifications to any tenant sign. In addition, LSU will provide final approval on the quality, number, color, size, and installation methods of all tenant signs.

MAXIMUM SIGNAGE SQUARE FOOTAGE

For the Historic District, the total area of all signage for each building frontage is recommended not to exceed one (1) square foot for each foot of lineal street frontage. For larger commercial buildings – such as those existing buildings found along Nicholson Drive that are often set back significantly from the street edge — the formula may increase to one and one half (1.5) square feet of sign area for each lineal foot of street frontage. In all cases, individual signs are limited in square footage, as described in the following guidelines

GENERAL

- LSU reserves the right to review and approve all sign colors, finishes, fabrication, and illumination.
- All signs and fastening devices shall be purchased and installed by the tenant.
- The tenant must obtain its own sign permits.
- It shall be the responsibility of the tenant to provide proper and continual maintenance for its sign(s) and sign structure(s).
- Sign text shall be limited to the name under which the tenant operates for business, as stated in the lease. Additional words, advertising describing products, services, logos, or target customers are generally not permitted, and must be reviewed and approved by LSU.

LSU FACILITY IDENTITY SIGNS (FA1)

- In some instances, at the discretion of the Office of Facility Development, tenants will be required to install a LSU Facility Identity Sign in addition retail signage.

TEMPORARY SIGNS

All temporary signs must be approved by LSU Office of Finance and Administrative Services.

FABRICATION TECHNIQUES

- Use of individually cut out letters, graphics, and logos are encouraged. Intent is to provide dimensionally interesting signage. LSU reserves the right to limit the use of logos.
- Installation should not damage or require removal of historic materials, and should be done in a manner such that signs can be removed without harm to the masonry or architectural detailing.
- All electrical components shall bear the UL label.
- No exposed conduit, tubing, or raceways will be permitted.
- All conductors, transformers, and other equipment shall be concealed.
- All attachment hardware, bolts, and clips shall be of corrosion resistant materials, to prevent staining of building surfaces.
- Formed plastic, injection-molded, or easily damaged signage materials are not permitted.
- Location of all openings for conduit and sleeves in sign panels of building shall be indicated by the sign contractor on drawings submitted to LSU. Installation shall be in accordance with the approved drawings.
- No sign-makers’ labels or other identification will be permitted on the exposed surface of signs, except those required by local ordinance which shall be located inconspicuously.
- Cinemas may have digital/electronic or changeable letter signs, subject to LSU approval of size, location and illumination.
- Awnings should be constructed from copper. Alternative materials (such as fabric) will be reviewed on a case-by-case basis by the LSU Office of Facility Development.

LIGHTING

Sign illumination is described in the following individual sign type descriptions. In general, all sign types shall comply with the following:

- LSU shall determine the hours that the signage may be illuminated. The intent is to provide a lively and safe environment at night, even beyond tenant operational hours.
- Halo-illuminated signage and lettering is encouraged.
- Neon used in open-face channel letters is permitted. Signage constructed solely of neon tubes is discouraged.
- Face-lighting or external illumination is encouraged.

APPLICATION AND PROCEDURE

Application for permits shall be made in writing to the Office of Facility Development, and are subject to its approval. Said applications shall contain the following information:

- Name, address, and telephone number of applicant.
- Location and position of sign.
- Scaled elevations and plans showing the building façade and the proposed sign, with specifications, sections, colors, proposed illumination, and materials.
- Written consent of the owner of the building and land.
- Such other information as the Building Inspector, Zoning Enforcement Officer, or regulatory board may require.
- In the case of any projecting symbol or banner sign, liability insurance in an appropriate amount to be determined by LSU shall be carried by the owner of said sign and a certificate of same shall be filed with the application.

PROHIBITED SIGNS AND CONDITIONS

For the area defined as the LSU Campus, the following signs are not permitted:

- Signage placed outside of LSU property, or within City or State right-of-way(s)
- Audible signs
- Non-accessory signs other than permitted temporary non-accessory signs
- Signage projecting above, or mounted to roof
- Offsite signage
- Backlit awnings
- Translucent (backlit) plastic sign faces



sign categories



fascia signage



DEFINITION

Letters or mark mounted parallel to the building's façade that are either mounted as individual letters, or contained in a sign panel.

GUIDELINES

Maximum area of sign: 60 sq. ft.

Number of signs: Unlimited

Mounting height: 20-foot maximum, provided it is below the sill line of the second floor windows or the lowest point of the roof, whichever is less.

Depth of sign: Wall signs should not project more than 8 inches from a building wall.

Illumination:

1. Natural lighting
2. External spot or flood lighting
3. Halo-lit or backlit letters



Recommended Mounting Locations (shaded areas above)

suspended signs



DEFINITION

Letters or mark applied to a panel, hung from the underside of a canopy.

GUIDELINES

Size: width should be less than or equal to the overhanging distance of a canopy at an usable entry, or less than or equal to half the overhanging distance of the canopy for non-entry applications.

Number of signs: Two (2) single-sided panels in the case of a usable entry. One (1) double-sided panel per ground level tenant at beginning of occupied frontage for building attachment.

Mounting height: Topmost extent of sign to be less than or equal to 6 inches below canopy, bottom may not have less than 10 feet of vertical clearance above grade or sidewalk.

Illumination: Natural or external lighting only



Recommended Mounting Locations (shaded areas above)



blade and shingle signs

DEFINITION

Mounted perpendicular to a building's façade, the shingle sign is typically suspended beneath an armature, and is able to swing from the axis of the pole, while the blade signs are typically mounted directly to the building façade using a rigid mounting bracket.

GUIDELINES

Maximum area of sign: 6 sq. ft.

Number of signs: One (1) per ground floor establishment, plus one (1) for any public building entrance not serving a ground floor establishment. All signs should be centered within architectural elements.

Mounting height: 20 foot maximum, provided it is below the sill line of the second floor windows or the lowest point of the roof, whichever is less, and does not have less than 10 feet of vertical clearance above grade or sidewalk.

Illumination: Natural or external lighting only



Recommended Mounting Locations (shaded areas above)

banner signs

DEFINITION

Fabric, or rigid material mounted with use of poles, typically oriented perpendicular to structure façade.

GUIDELINES

Area of banner: Less than or equal to 25 sq. ft.

Number of banners: Varies; however, banners should be spaced no closer than 20 feet apart, and centered within architectural elements.

Projection: Banners should not project more than 3' into the public right-of-way.

Mounting height: Bottom of banners should be mounted at least 14' above grade or sidewalk to avoid intrusion into Blade Sign or Awning Zone, and should not extend beyond the third story of the structure.

Illumination: Natural or external lighting only



Recommended Mounting Locations (shaded areas above)



awnings and canopies

DEFINITION

Roof-like structures, above storefront windows or entries, sometimes containing a mark or signature of a tenant.

GUIDELINES

Length: Awnings and canopies should not exceed 20' in horizontal length and should be centered within architectural elements, such as doors or columns.

Projection: Awnings and canopies should not project more than 5' into the public right-of-way, except where located above an operable building or shop entry, in which case the maximum projection shall not exceed 10'.

Mounting height: The bottom of awnings and canopies should be at least 8' above grade or sidewalk, except in the case of a movable valance which may be 7' above grade or sidewalk.

Illumination: Natural lighting only; backlit awnings are not permitted

Design: On multi-tenant façades, use common design elements. Logo or tenant mark should be limited to the valance of an awning, or the front plane of the canopy. Retractable or open sided awnings are preferred, with or without drop valances.



Recommended Mounting Locations (shaded areas above)

wall plaques

DEFINITION

Small, pedestrian-oriented informative signs that may convey information such as hours of operation or take the form of directories, menu cases, or convey historical building information.

GUIDELINES

Area of sign: Up to 6 sq. ft. in area, not projecting more than 3 inches from a building wall

Number of signs: 2 per usable entry.

Mounting height: 5 feet on center above grade or sidewalk.

Illumination:

1. Natural lighting
2. Internal lighting (for menu cases only)

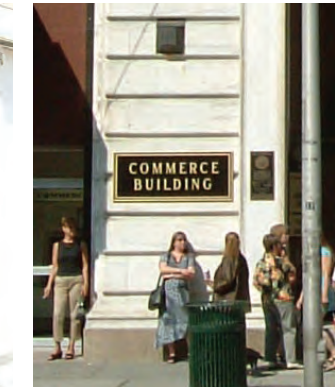

Recommended Mounting Locations (shaded areas above)

street address



DEFINITION

Plaque mounted to side of building at pedestrian level, or dimensional letters mounted above door conveying at the minimum the numerical street address of the building.

GUIDELINES

Area of sign: Less than or equal to 3 sq. ft. in area.

Number of signs: Minimum of one (1) located at the main entry to the building.

Mounting height: 5 feet on center for wall mounted, horizontally centered above door(s), or on the sides of a canopy. Numerals mounted overhead should be no less than 8 inches tall.

Illumination:

1. Natural lighting
2. Halo lit or backlit letters



Recommended Mounting Locations (shaded areas above)

storefront window graphics



DEFINITION

Window graphics can be permanent with the tenant's mark, or hours of operation.

GUIDELINES

Area: Window signs should not obscure the interior view of a retail establishment, and should be no greater than 10% of the available window space.

Number of signs: Limited only by area occupied

Illumination: Ambient



Recommended Mounting Locations: Permanent Window Graphics (shaded areas above)

campus facilities

OCCUPANCY MAP

FACILITY IDENTIFICATION

Use of the LSU Law and Ag Center affiliate logos on the FA1, FA2, and FA3 signs shall be guided by the attached facility occupancy map. Current versions of the map shall be obtained from the LSU Office of Facility Development and Campus Planning.

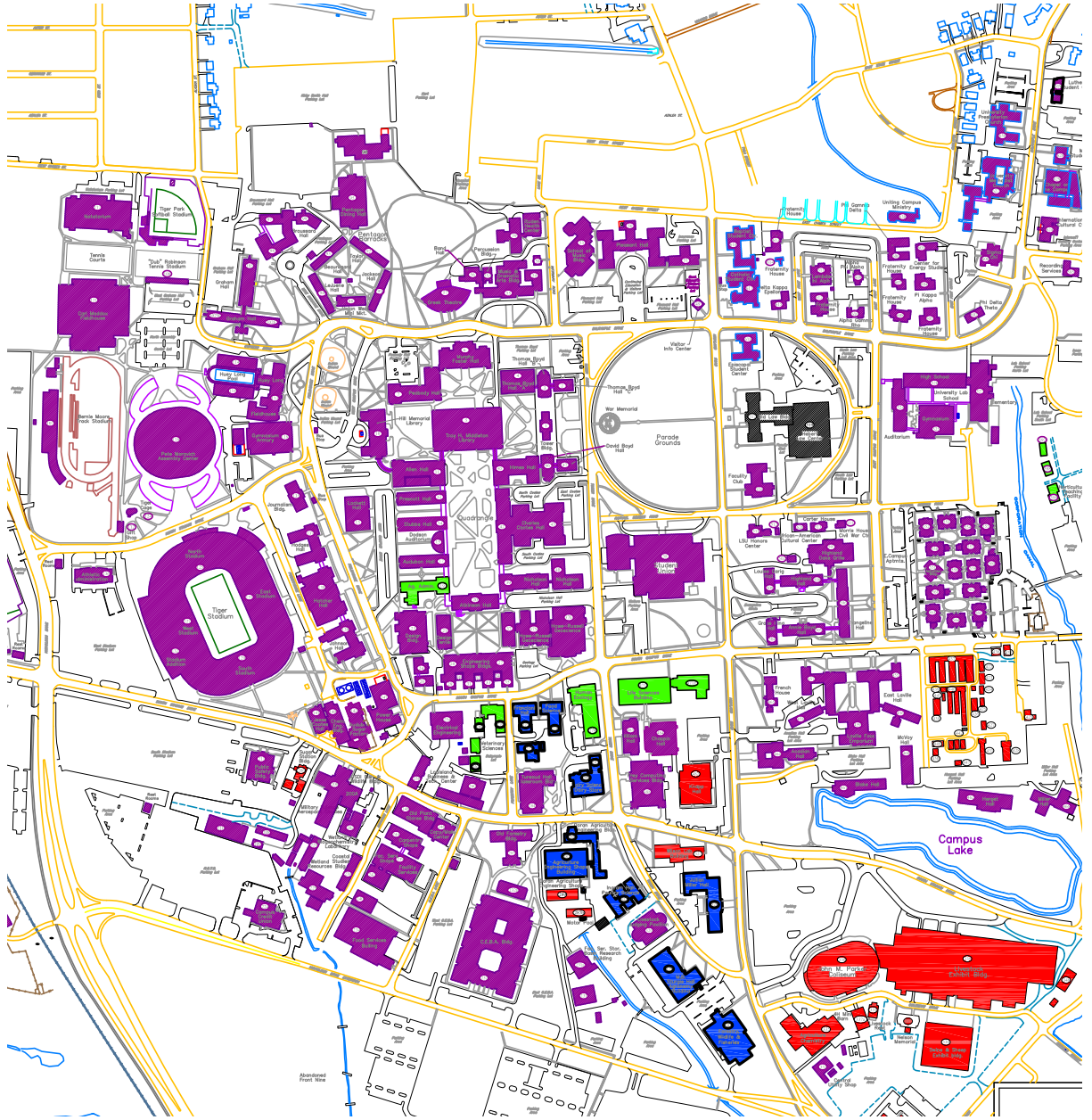

LEGEND	
■	100% LSU AG CENTER
■	MOSTLY LSU AG CENTER
■	100% LSU & A&M
■	MOSTLY LSU & A&M
■	LSU LAW CENTER

16 FEBRUARY 2010

LSU

Addendum to Wayfinding and Signage Guidelines

- Donor and Corporate Recognition
- Greek Wayfinding
- Exterior Retail

nbbj

September 2017

CONTENTS

DONOR RECOGNITION & CORPORATE SPONSORS

	Sheet Number
Introduction	GR.01
Concept Overview	GR.02
Donor Recognition Strategy	GR.03
Donor Tier System	GR.04
Typefaces and Materials	GR.05
Sign Type A	GR.06
Sign Type B	GR.07
Sign Type C	GR.08
Sign Type D	GR.09
Sign Type E	GR.10
Sign Type E Alternate Length	GR.11
Sign Type E Alternate Mounting	GR.12
Medallion	GR.13
Corporate Sponsors Guidelines	GR.14-15

GREEK SIGNAGE

	Sheet Number
Greek Signage Monument	GR.17
Monument Render	GR.18

RETAIL GUIDELINES

	Sheet Number
Retail Signage Guidelines	GR.20

DONOR RECOGNITION & CORPORATE SPONSORS

Introduction

The following package implements Donor Recognition Signage guidelines as a supplementary addition to the existing LSU Wayfinding Guidelines established in 2010. This document provides design intent details for each of the new defined sign types. The signs outlined in this document uphold the design principles of the existing guidelines, while intentionally differentiating slightly as to establish a clear and separate donor recognition visual language.

This document is intended to serve as prescriptive standards for signage general shape and size, details, and text layout. Donor tiers, final materiality, message, and placement details are provided as guidelines, but are ultimately up to the LSU staff.



Design Rationale

Historically, donor recognition on the LSU campus has lacked consistency, both in design and implementation. These guidelines are intended to bring uniformity to the LSU campus, establish a recognizable visual language for donor signage separate from wayfinding signage, and through beautiful, prominent monuments, generate donation interest from new donor prospects.

The 5 signs detailed in this document vary based on corresponding donation amount, but all follow the same guiding objectives:

- “LSU-esque”, tasteful & classic
- Versatility to be appropriate for different architecture
- Prioritize prominence over size
- Thoughtful materiality
- Complement existing wayfinding signage, not compete
- Simplicity of message & form
- Respectful of context & history
- Flexibility to grow with the campus
- Establish a clear hierarchy of donor levels
- Avoid “headstone” style monuments





Concept Overview

By using a material that can be seen in historical buildings on the LSU campus and surrounding Louisiana area, this concept has deep roots in the culture and history of the region. When designed in a simple, modern way, wrought iron (and the accompanying pattern elements) helps link contemporary architecture with buildings that have become campus icons. Light could be introduced to help bring attention to the largest donations and give these markers a presence on campus, even at night.

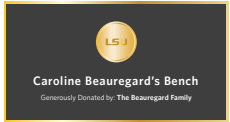

Wrought iron as a primary material helps this donor recognition system fit well within the context of existing wayfinding conditions. They feel similar and related, but carry a great sense of quality and “specialness”.



LSU Donor Recognition Tiers / Strategy				
Tier	Sign Type	Donation Range	Sample Site	Sign Shape (Not to Scale)
1	A	\$100K — \$500K	Bench / Sculpture / Art	
2	B	\$500K — \$1M	Garden / Small Area	
3	C	\$1M — \$5M	Courtyard / Renovation	
4	D	\$5M — \$10M	New Building	
5	E	\$10M+	College of Study	

Tier System



SIGN TYPE: A

SIGN TYPE: B

SIGN TYPE: C

SIGN TYPE: D

SIGN TYPE: E

Standards & Materials

Typography

W BOOK
Whitney Book Regular

Aa Bb Cc Dd Ee Ff Gg Hh Ii
Jj Kk Ll Mm Nn Oo Pp Qq Rr
Ss Tt Uu Vv Ww Xx Yy Zz

W BOLD
Whitney Bold

Aa Bb Cc Dd Ee Ff Gg Hh Ii
Jj Kk Ll Mm Nn Oo Pp Qq Rr
Ss Tt Uu Vv Ww Xx Yy Zz

Material Swatches

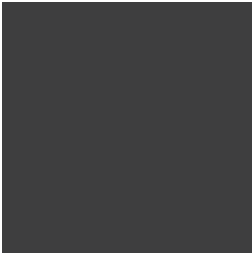

M1
Matthews Paint — Black Mamba



MTL1
Polished and anodized aluminum
(gold) satin finish

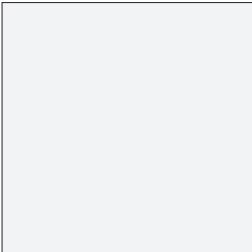

M2
Matthews Paint — Natural White



MTL2
Polished and anodized aluminum
(gold) mirror finish

Logo Lock-up



Material and finish samples to be reviewed by LSU staff for approval prior to fabrication.

SIGN TYPE: A

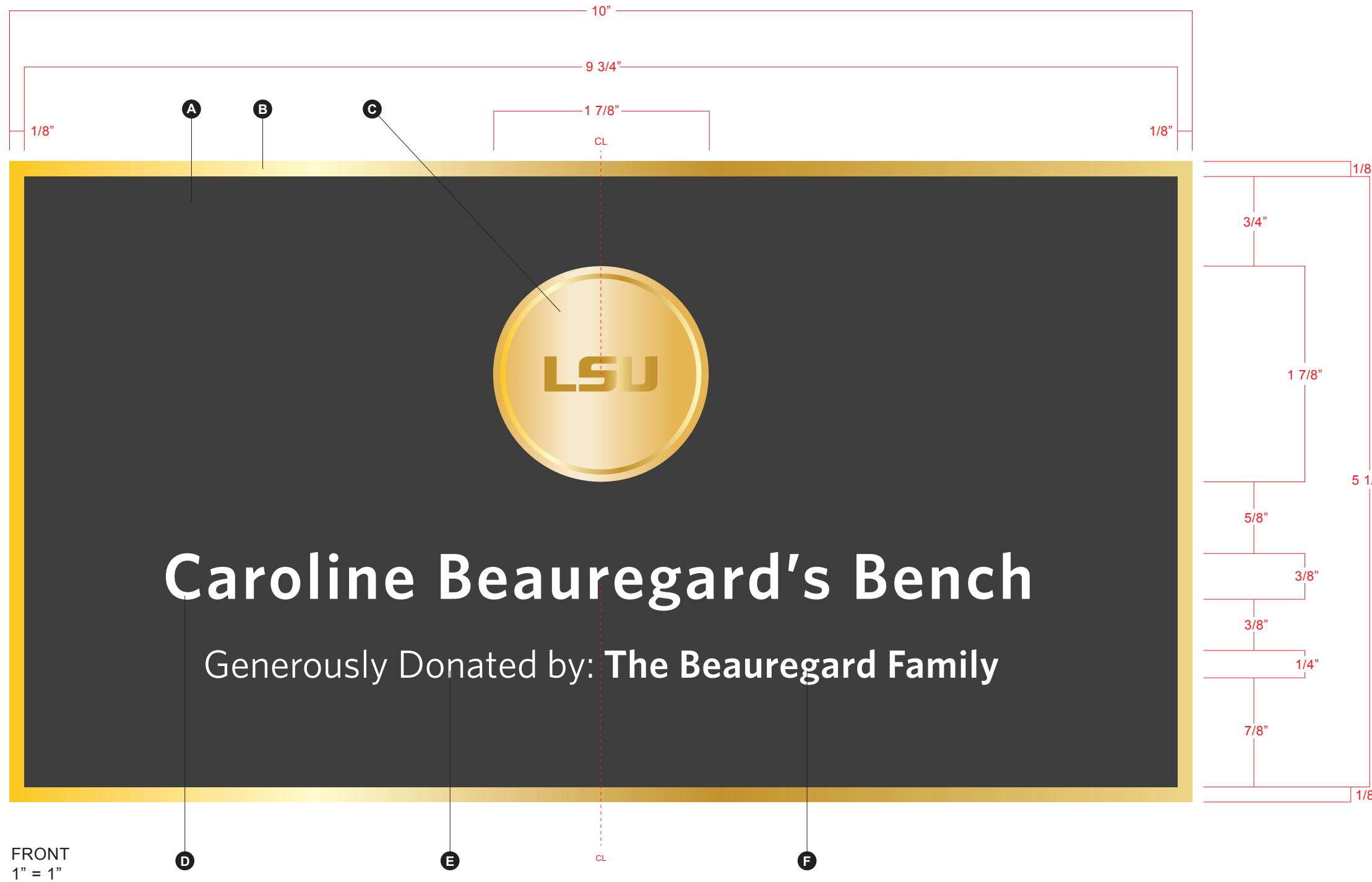

FABRICATION NOTES:

- A** 3/16" thick aluminum plate, powder-coated finish to match M1.
- B** 3/16" thick aluminum plate, gold mirror-polished to match MTL2.
- C** Cast aluminum medallion (SMALL) with anodized gold color. See detail page MEDALLION. Inset / secure medallion into routed opening in cabinet (A).
- D** 1/16" deep etch text (W BOLD), infill with white paint to match M2.
- E** 1/16" deep etch text (W BOOK), infill with white paint to match M2.
- F** 1/16" deep etch text (W BOLD), infill with white paint to match M2.

GENERAL NOTES:

Locations and messages TBD by LSU staff.

USAGE AND PLACEMENT NOTES:

Sign Type A is a plaque design for the lowest tier of donations, 100K - 500K. Donations of this amount are associated with smaller objects, such as benches, trees, significant windows, etc.

This plaque should be placed with close visual association to the donated object, and should not be obstructed by any landscaping or other signage.

SIGN TYPE: B

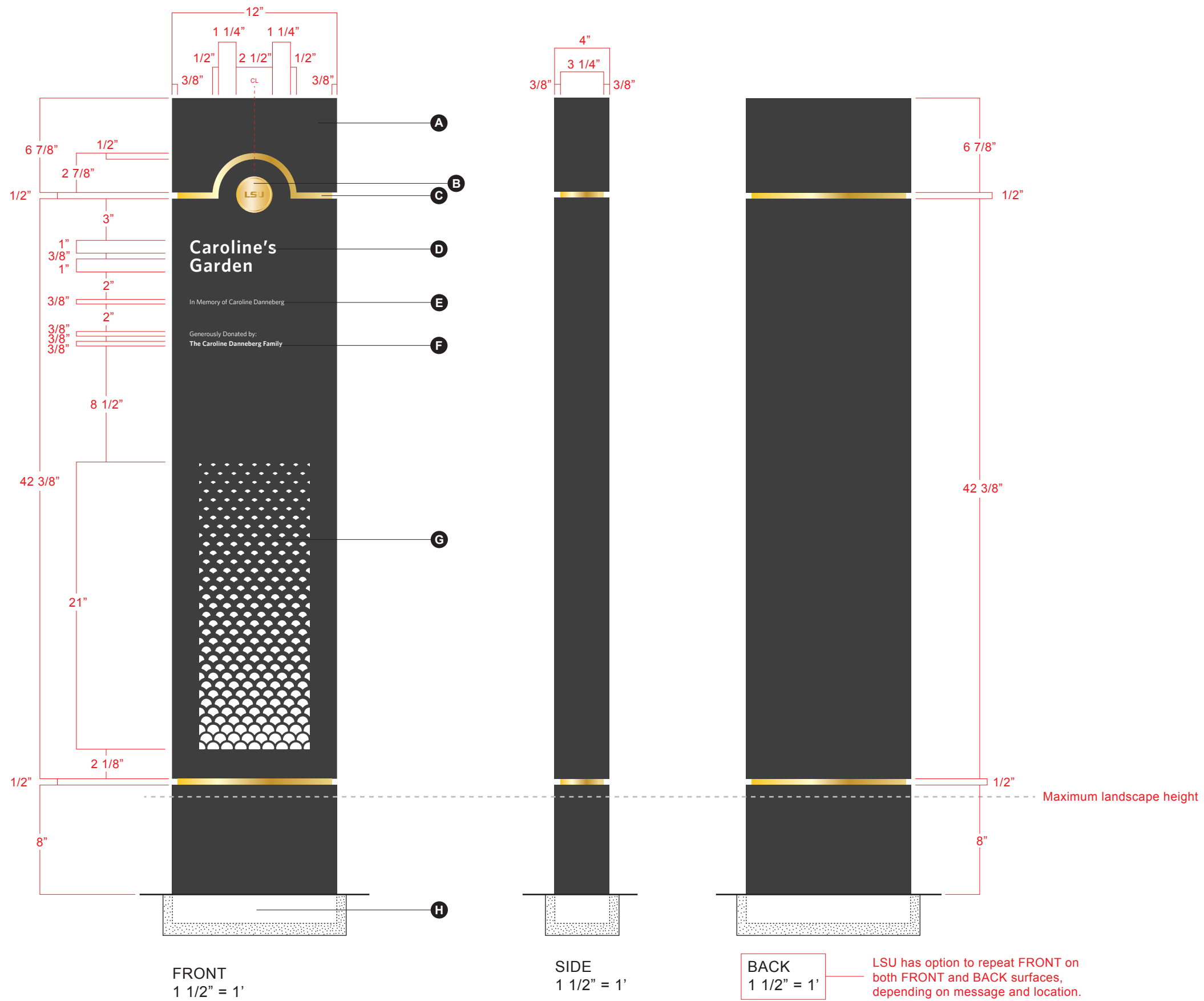

FABRICATION NOTES:

- A** 3/16" thick aluminum cabinet, powder-coated finish to match M1. Middle cabinet to have primary text (D) hydrojet cut out of face.
- B** Cast aluminum medallion (MEDIUM) with anodized gold color. See detail page MEDALLION. Inset / secure medallion into routed opening in cabinet (A).
- C** Gold mirror-polished aluminum accents, to match MTL2.
- D** 1/2" frosted acrylic with sanded edges, pushed thru face of cabinet, back with white diffuser film.
- E** 1/16" deep etch text (W BOOK), infill with white paint to match M2.
- F** 1/16" deep etch text (W BOLD), infill with white paint to match M2.
- G** Arch pattern hydrojet cut out of face of cabinet (A), back with frosted acrylic diffuser.
- H** Below-grade foundation shown for example only, fabricator to engineer and determine requirements.

GENERAL NOTES:

Internally illuminate cabinet using bright white LEDs. Even illumination, no hotspots or dark areas.

Locations and messages TBD by LSU staff.

USAGE AND PLACEMENT NOTES:

Sign Type B is a monument design for the 500K - 1M range. Donations of this amount are associated with smaller outdoor spaces, such as gardens.

This monument should be placed at the most used entry to the area. Message should be repeated on back if visible from inside the area.

SIGN TYPE: C



FRONT
1 1/2" = 1'

SIDE
1 1/2" = 1'

BACK
1 1/2" = 1'

LSU has option to repeat FRONT on both FRONT and BACK surfaces, depending on message and location.

FABRICATION NOTES:

- A** 3/16" thick aluminum cabinet, powder-coated finish to match M1. Middle cabinet to have primary text (D) hydrojet cut out of face.
- B** Cast aluminum medallion (MEDIUM) with anodized gold color. See detail page MEDALLION. Inset / secure medallion into routed opening in cabinet (A).
- C** Gold mirror-polished aluminum accents, to match MTL2.
- D** 1/2" frosted acrylic with sanded edges, pushed thru face of cabinet, back with white diffuser film.
- E** 1/16" deep etch text (W BOOK), infill with white paint to match M2.
- F** 1/16" deep etch text (W BOLD), infill with white paint to match M2.
- G** Arch pattern hydrojet cut out of face of cabinet (A), back with frosted acrylic diffuser.
- H** Below-grade foundation shown for example only, fabricator to engineer and determine requirements.

GENERAL NOTES:

Internally illuminate cabinet using bright white LEDs. Even illumination, no hotspots or dark areas.

Locations and messages TBD by LSU staff.

USAGE AND PLACEMENT NOTES:

Sign Type C is a monument design for the 1M - 5M range. Donations of this amount are associated with larger outdoor spaces or renovated areas, such as courtyards.

This monument should be placed at the most used entry to the area. Message should be repeated on back if visible from inside the area.

SIGN TYPE: D

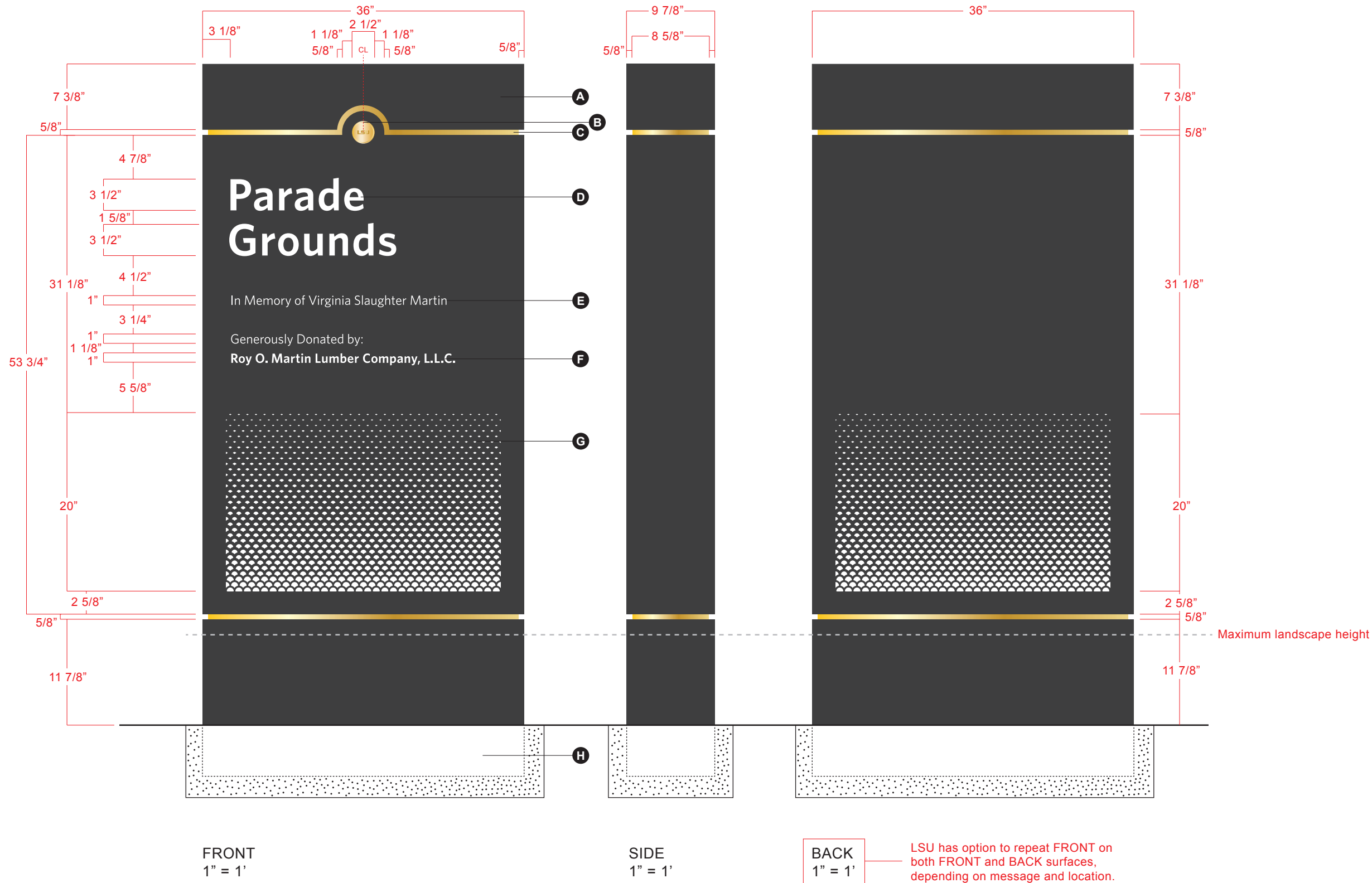

FABRICATION NOTES:

- A** 3/16" thick aluminum cabinet, powder-coated finish to match M1. Middle cabinet to have primary text (D) hydrojet cut out of face.
- B** Cast aluminum medallion (MEDIUM) with anodized gold color. See detail page MEDALLION. Inset / secure medallion into routed opening in cabinet (A).
- C** Gold mirror-polished aluminum accents, to match MTL2.
- D** 1/2" frosted acrylic with sanded edges, pushed thru face of cabinet, back with white diffuser film.
- E** 1/16" deep etch text (W BOOK), infill with white paint to match M2.
- F** 1/16" deep etch text (W BOLD), infill with white paint to match M2.
- G** Arch pattern hydrojet cut out of face of cabinet (A), back with frosted acrylic diffuser.
- H** Below-grade foundation shown for example only, fabricator to engineer and determine requirements.

GENERAL NOTES:

Internally illuminate cabinet using bright white LEDs. Even illumination, no hotspots or dark areas.

Locations and messages TBD by LSU staff.

USAGE AND PLACEMENT NOTES:

Sign Type D is a monument design for the 5M - 10M range. Donations of this amount are associated with new buildings or outdoor areas of great significance.

This monument should be placed in the landscape as if intentionally included in the landscape design. It should be away from any wayfinding signs identifying building names. Message should be repeated on back if visible from inside the area.

SIGN TYPE: E

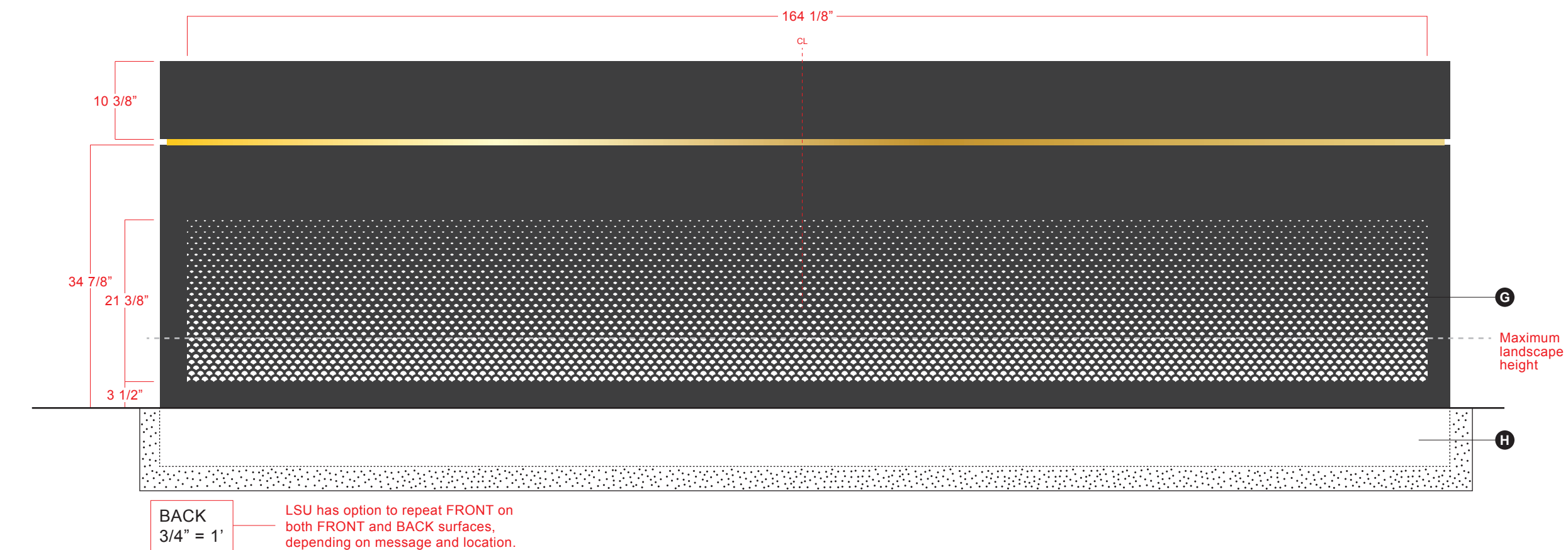
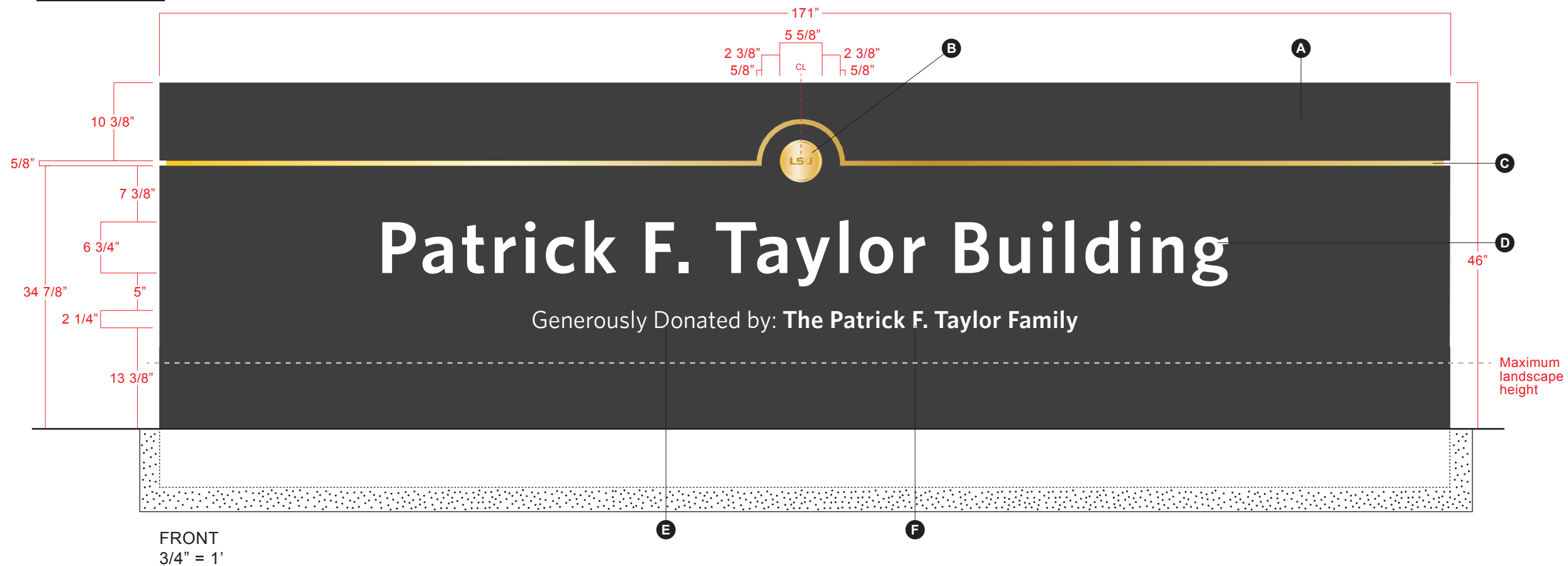

FABRICATION NOTES:

- A** 3/16" thick aluminum cabinet, powder-coated finish to match M1. Middle cabinet to have primary text (D) hydrojet cut out of face.
- B** Cast aluminum medallion (LARGE) with anodized gold color. See detail page MEDALLION. Inset / secure medallion into routed opening in cabinet (A).
- C** Gold mirror-polished aluminum accents, to match MTL2.
- D** 1/2" frosted acrylic text (W BOLD) with sanded edges, pushed thru face of cabinet, back with white diffuser film.
- E** 1/16" deep etch text (W BOOK), infill with white paint to match M2.
- F** 1/16" deep etch text (W BOLD), infill with white paint to match M2.
- G** Arch pattern hydrojet cut out of face of cabinet (A), back with frosted acrylic diffuser.
- H** Below-grade foundation shown for example only, fabricator to engineer and determine requirements.

GENERAL NOTES:

Internally illuminate cabinet using bright white LEDs. Even illumination, no hotspots or dark areas.

Locations and messages TBD by LSU staff.

USAGE AND PLACEMENT NOTES:

Sign Type E is a monument design for the 10M+ range. Donations of this amount are associated with entire building complexes or new construction of significant importance.

This monument should serve as the primary building sign, and LSU staff should consider omitting the existing wayfinding sign to avoid clutter and repetition.

SIGN TYPE: E

ALTERNATE LENGTH

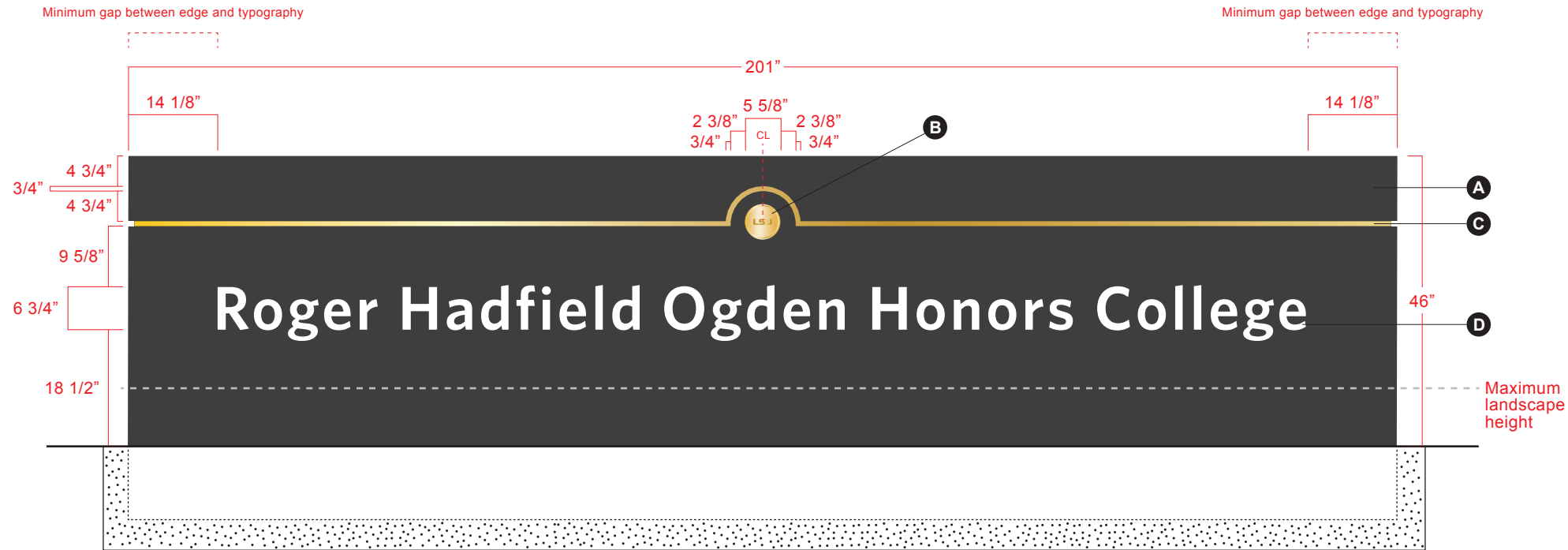

FRONT
1/2" = 1'

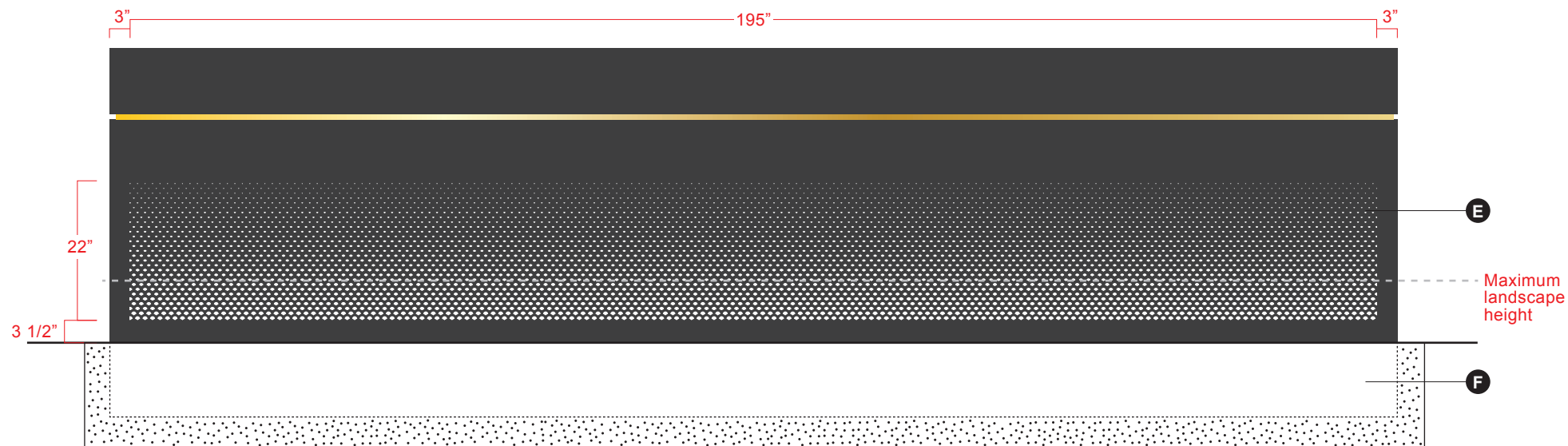

BACK
1/2" = 1'

LSU has option to repeat FRONT on both FRONT and BACK surfaces, depending on message and location.

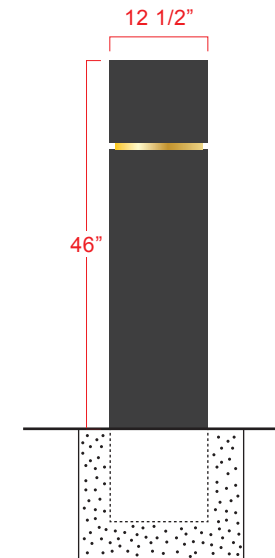

SIDE
1/2" = 1'

FABRICATION NOTES:

- A** 3/16" thick aluminum cabinet, powder-coated finish to match M1. Middle cabinet to have primary text (D) hydrojet cut out of face.
- B** Cast aluminum medallion (LARGE) with anodized gold color. See detail page MEDALLION. Inset / secure medallion into routed opening in cabinet (A).
- C** Gold mirror-polished aluminum accents, to match MTL2.
- D** 1/2" frosted acrylic text (W BOLD) with sanded edges, pushed thru face of cabinet, back with white diffuser film.
- E** Arch pattern hydrojet cut out of face of cabinet (A), back with frosted acrylic diffuser.
- F** Below-grade foundation shown for example only, fabricator to engineer and determine requirements.

GENERAL NOTES:

Internally illuminate cabinet using bright white LEDs. Even illumination, no hotspots or dark areas.

Locations and messages TBD by LSU staff.

SIGN TYPE: E

ALTERNATE ON EXISTING WALL

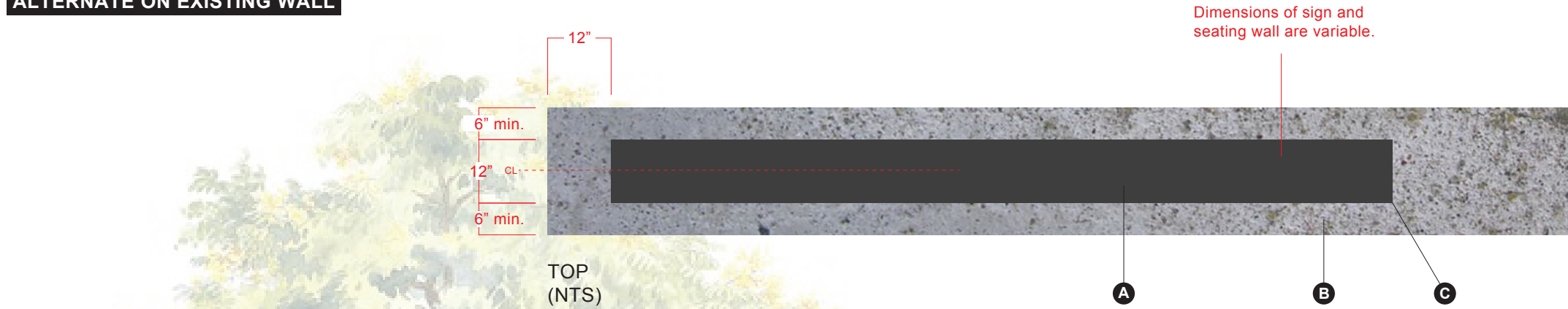

FABRICATION NOTES:

- A** Alternate installation of Sign Type E.
- B** Existing concrete seating wall.
- C** Secure cabinet to seating wall using concealed fasteners. Fabricator to determine attachments.

GENERAL NOTES:

Internally illuminate cabinet using bright white LEDs. Even illumination, no hotspots or dark areas.

Locations and messages TBD by LSU staff.

Installation distances will change based on specifications of the seating wall.

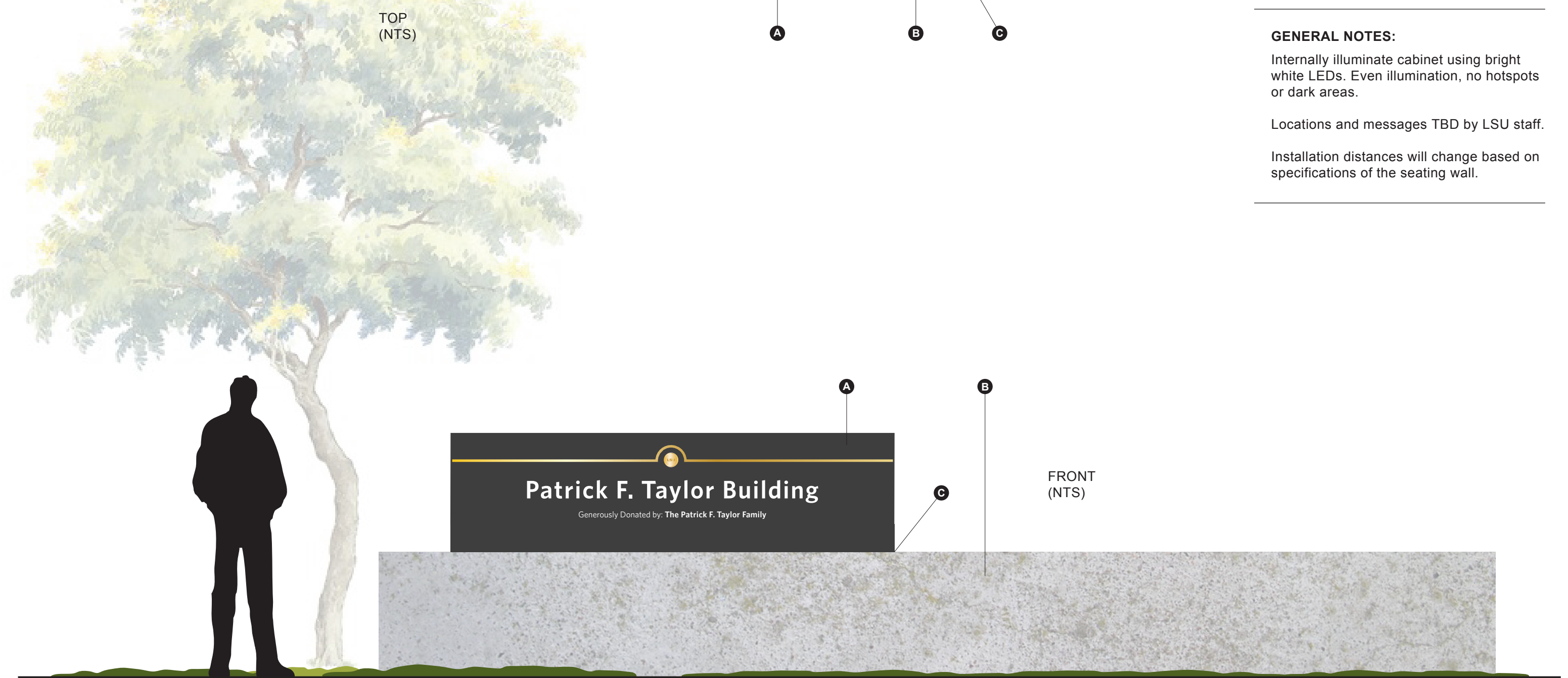

MEDALLION

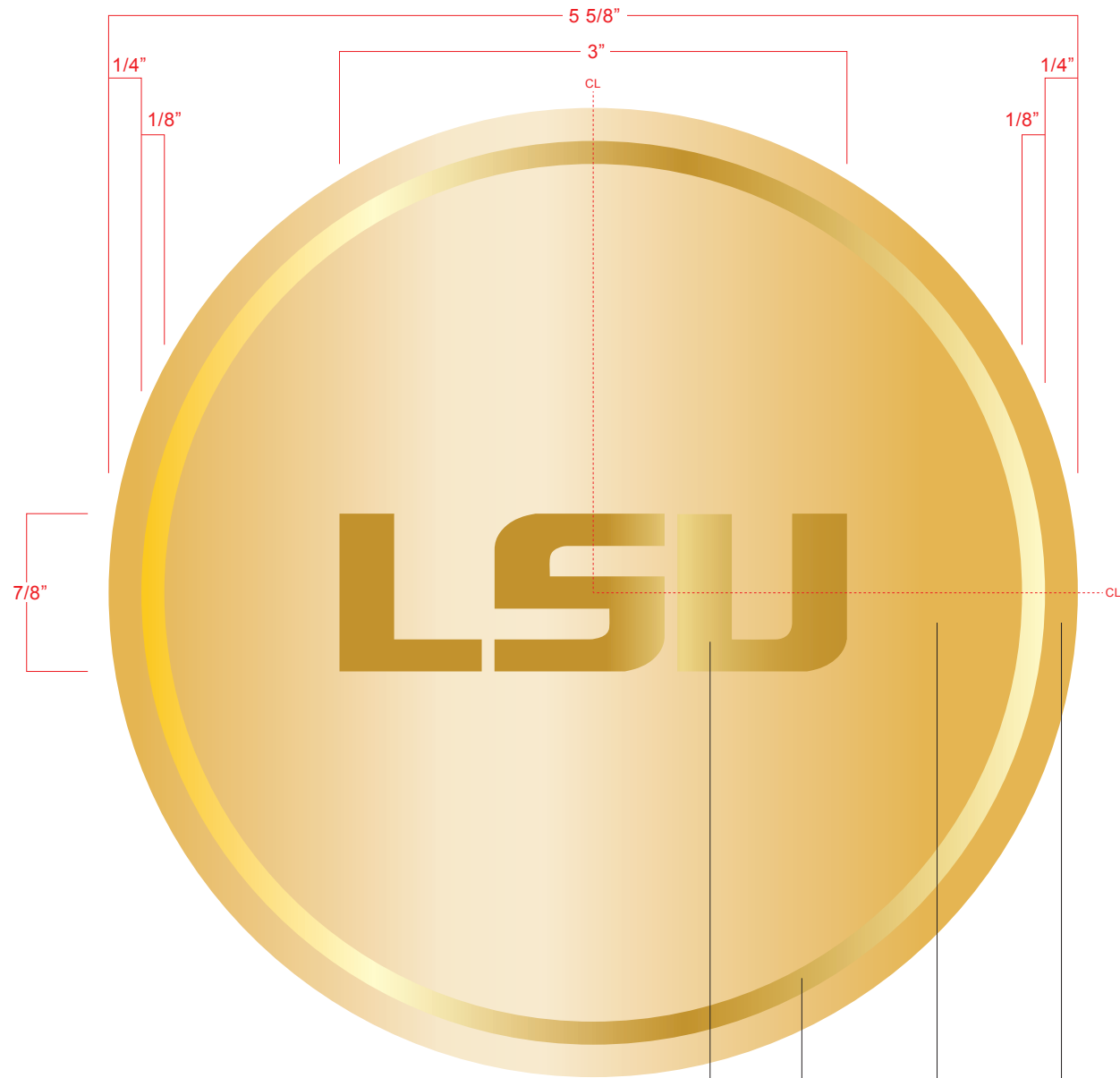

FRONT — LARGE
1" = 1"

B B A A

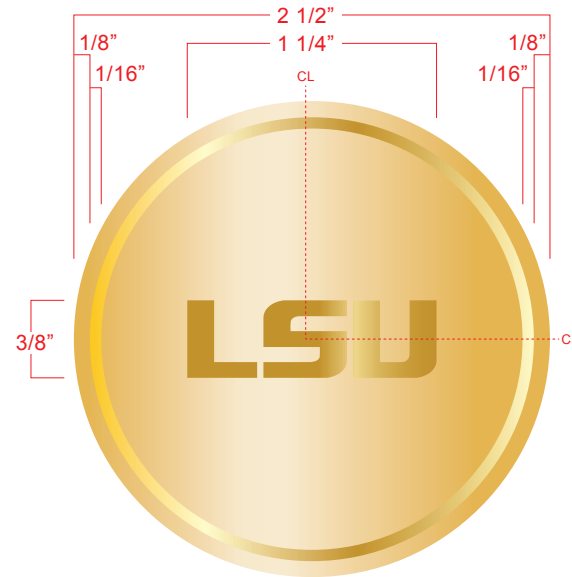

FRONT — MEDIUM
1" = 1"

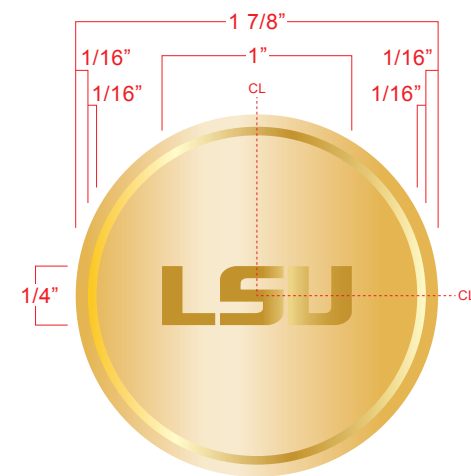

FRONT — SMALL
1" = 1"

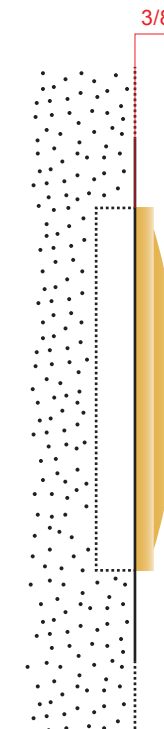

SIDE
(NTS)

Medallion to have gentle dome and to be embedded within the cabinets to prevent vandalism.

FABRICATION NOTES:

- A** Cast aluminum medallion with anodized gold color, satin finish to match MTL1. Beveled.
- B** Logo and edge trim to be anodized gold color, mirror finish (MTL2).

GENERAL NOTES:

This drawing intended to specify materials. Please refer to final art files for scale.

Locations and messages TBD by LSU staff.

LSU may choose to fabricate additional medals (standalone) with custom engraving for donor thank-you gifts.

Medallion sample to be reviewed by LSU staff for approval prior to fabrication.

USAGE AND PLACEMENT NOTES:

In all instances, no corporate logos are to appear on donor recognition signage. Depending on the donation amount, a corporate sponsor should be credited with their company name on the appropriate recognition monument and comply with the existing size and font outlined in this document.

- A** For most donations which do not receive naming rights, the corporate sponsor's name will appear with "Generously donated by: (sponsor's name)".
- B** For large donors who do get naming rights, the sponsor should receive a top tier donor monument with sponsor's name as well as a wayfinding sign of the same name.





Imagery of sample mounting methods for corporate sponsors name on buildings



USAGE AND PLACEMENT NOTES:

LSU is in the process of rolling out campus-wide wayfinding signage with landscape signs and monuments. To maintain consistency, and avoid legibility issues with tree cover and varying architectural styles, LSU should refrain from putting names directly onto buildings.

In the event of a special request or an appropriate instance determined by LSU staff to install a name on a building, a single panel or shelf should be used to avoid multiple drill holes in the event of a changing name in the future. Lighting should be external and should match the architectural character and finishes of the building on which it resides.

GREEK SIGNAGE

GREEK HOUSING
monument sign

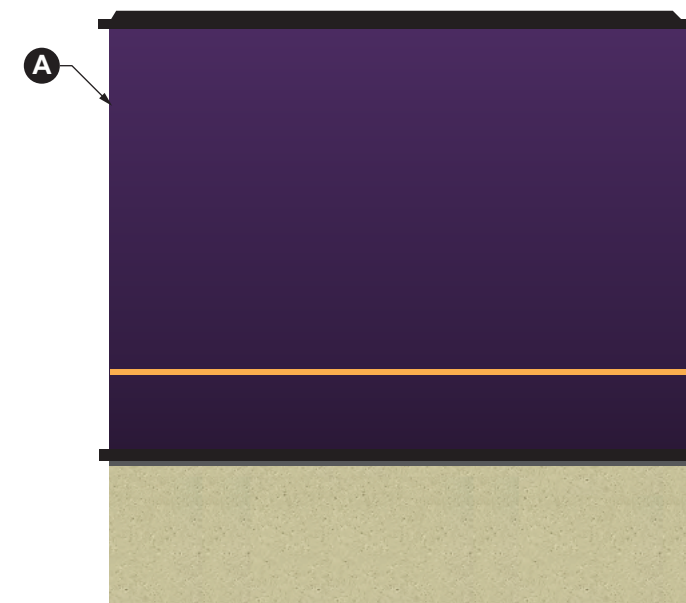
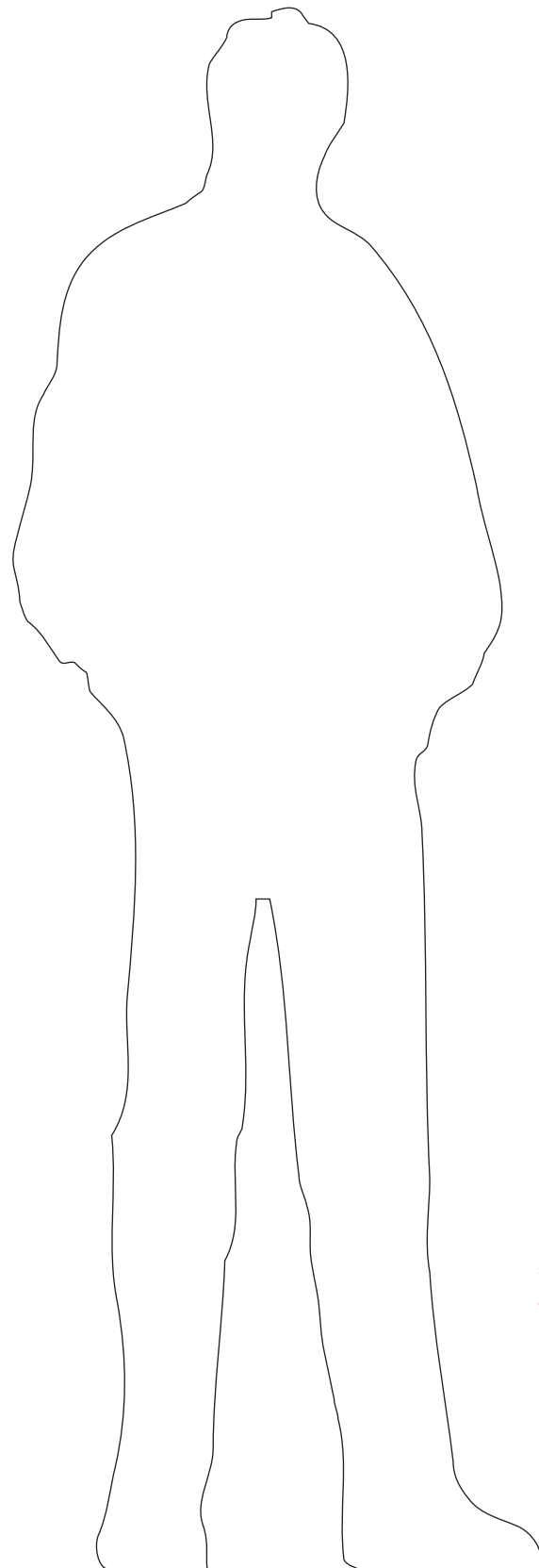

FABRICATION NOTES

- A** Monument material and fabrication methods to match that of Vehicular Directional signage from LSU Wayfinding Guidelines (pg. 131).
- B** Greek Letters: Whitney Semibold
Phonetic Spelling: Whitney Medium
Address: Whitney Bold, tracking 150pt.
- C** LSU logo cast into concrete

Monument should be parallel to street, set back at least 7 ft from curb.

Monument to be externally lit.



RETAIL GUIDELINES

LSU Nicholson Gateway Development

Design Standard – Retail Component

LSU Nicholson Gateway Development

Design Standard – Retail Component

S-02 Retail Component

This document originally developed by B&D and LSU, and edited by NBBJ in May, 2017.

These standards are provided to frame LSU's anticipated Design Criteria for the retail spaces located within the NGD. The Developer should propose Design Criteria for the retail component commensurate with the Developer's plan for the NGD. As with any project on LSU's campus, LSU will approve tenants and review design submittals for tenant build-outs in the retail component in cooperation with the Developer or Developer's appointed agent.

A. Signage Criteria

- 1) Signage must be integral to the tenant's store front design concept
- 2) Signage shall compliment the overall storefront, general building design, and the broader context of Nicholson Gateway and Louisiana State University
- 3) All signs are subject to review and approval by LSU OFS
- 4) Tenant shall be fully responsible for workmanship, installation and maintenance of tenant's signage
- 5) Tenant shall be allowed to install one illuminated, primary façade sign over the Tenant's storefront on the exterior surface of Tenant's fronting lease line
- 6) All primary façade signs over Tenant's storefront must be illuminated
- 7) Tenants in the free-standing retail spaces shall be permitted to install a secondary façade sign to be 50% or smaller than the primary façade sign
- 8) Signs shall be parallel to and directly over the storefront entry within the limits of the tenant's lease space
- 9) Signs are limited to tenant's store name letterforms and/or iconographic symbol – no other descriptive elements are permitted on façade signs
- 10) Cabinet or box signs are not permitted – custom, vacuum pressed or molded signs are acceptable
- 11) The horizontal dimension of the sign shall not exceed two-thirds the width of the overall storefront elevation and shall not exceed an overall vertical dimension of 3'-0"
- 12) Signs may have a background but must appear architecturally and aesthetically integrated with the overall building
- 13) Façade signs may extend a maximum of 10" outward beyond the lease line – no blade or flag signs
- 14) Additional wayfinding signs are permitted in compliance with LSU's Wayfinding standards
- 15) Additional signage integrated into the tenant's storefront façade is acceptable upon review such as glass work or hand painted murals – applied or otherwise adhered signs are prohibited
- 16) Tenant identification such as applied lettering/logo must be in white or varying levels of white opacity and may be used to a maximum of 6" in height, centered side to side between mullions, a maximum of 5'-0" above finish grade – alternates subject to review
- 17) Multi-tenant signage standards for retail use shall follow the intent of LSU's Wayfinding standards and are subject to review by LSU OFS for initial signage structure and infill tenant components. Site signage locations for the landlord's use are to be determined during landlord's schematic design review
- 18) The following signs are prohibited unless otherwise noted:
 - a. Flashing or animated signs
 - b. Internally illuminated cabinet or box signs with full acrylic faces
 - c. Exposed neon signs
 - d. Audible or odor producing signs
 - e. Handwritten signs
 - f. Freestanding signs
 - g. Painted lettering on brick, stone, or metal
 - h. Exposed, unfinished aluminum



nbbj

LSU Nicholson Gateway Development

Design Standard – Retail Component

- l. Cloth, paper, cardboard signs or signs of other temporary non-durable materials
- 19) Preferred materials, illumination and fabrication techniques for signage:
- a. Reverse channel, white halo illuminated metal letters and graphics, letter faces may be in color
 - b. Non-internally illuminated fabricated metal letters and graphics
 - c. Cast metal letters and graphics
 - d. Remote illumination must be from above with matching fixtures, sign faces may not be reflective. Light fixtures must match building architectural character in metal finish and color. Approval of light fixtures subject to review by LSU staff. Lighting must be with daylight-toned LED bulbs.
 - e. Cast, fabricated, or painted metals
 - f. Incised signing cast into or carved out of an opaque material, indirectly lit
 - g. Stainless steel, perforated metal, wire mesh
 - h. Cast, molded or fabricated 3D objects
 - i. Internal or LED/neon lighting may be used if inside a reverse channel letter where neon is protected and light is contained. Any neon application approval is subject to review by LSU staff.
- 20) For ease of changeability in the future, signs may be either individual letters mounted to a singular removable background panel or letters may rest on a single ledge that is attached to the building or a canopy.

end

end

nbbj
Studio 07